

Description

The F6101 is an 8-channel receiver silicon IC designed using a SiGe BiCMOS process for Ku-Band SATCOM phased array applications. The core IC has 6-bit phase control coupled with more than 30dB gain control on each channel to achieve fine beam steering and gain compensation between channels. The device has 15.5dB nominal electric gain and -23dBm IP1dB. The core chip achieves an RMS phase error of 2.5° and RMS gain error of 0.25dB over the frequency of operation. The typical total power consumption is 0.34W (43mW per channel).

Competitive Advantage

- High integration
- Orthogonality of phase and amplitude control
- Advanced Serial Peripheral Interface (SPI) with 4-state memory
- Superior channel-to-channel isolation
- Minimal footprint

Typical Applications

- Ku-Band SATCOM
- Aerospace and Maritime
- Weather Radar
- Beam Steering
- Test and Measurement

Features

- 10GHz to 14GHz operation
- 8 radiation channels
- 6-bit phase control
- 20ns typical gain settling time
- 20ns typical phase settling time
- 2.5° typical RMS phase error
- 0.25dB typical RMS gain error
- 30dB gain attenuation range
- 5-bit IC address
- Integrated proportional-to-absolute temperature (PTAT) sensor with external biasing
- -40°C to +95°C internal temperature sensor
- Programmable 4-state on-chip memory
- Supply voltage: +2.1V to +2.5V
- -40°C to +95°C ambient operating temperature range
- 27°C typical ambient operating temperature
- 5mm x 5mm, 40-QFN package

Block Diagram

Figure 1. Block Diagram

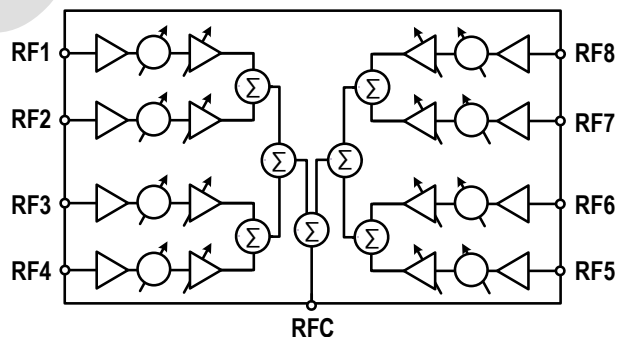

Ordering Information

Orderable Part Number	Package	MSL Rating	Carrier Type	Temperature
F6101NTGK	5mm x 5mm 40-QFN	MSL 3	Tray	-40° to +95°C
F6101NTGK8	5mm x 5mm 40-QFN	MSL 3	Reel	-40° to +95°C
F6101EVB	Evaluation Board			
F6101EVS	F6101 Evaluation Kit System, including Evaluation Board, 2x THRU Reference Fixture, FT2232H Mini-Module Microcontroller, Digital Cable, Power Cable, and USB-to-Mini Cable			

Advanced

IMPORTANT NOTICE AND DISCLAIMER

RENESAS ELECTRONICS CORPORATION AND ITS SUBSIDIARIES (“RENESAS”) PROVIDES TECHNICAL SPECIFICATIONS AND RELIABILITY DATA (INCLUDING DATASHEETS), DESIGN RESOURCES (INCLUDING REFERENCE DESIGNS), APPLICATION OR OTHER DESIGN ADVICE, WEB TOOLS, SAFETY INFORMATION, AND OTHER RESOURCES “AS IS” AND WITH ALL FAULTS, AND DISCLAIMS ALL WARRANTIES, EXPRESS OR IMPLIED, INCLUDING, WITHOUT LIMITATION, ANY IMPLIED WARRANTIES OF MERCHANTABILITY, FITNESS FOR A PARTICULAR PURPOSE, OR NON-INFRINGEMENT OF THIRD PARTY INTELLECTUAL PROPERTY RIGHTS.

These resources are intended for developers skilled in the art designing with Renesas products. You are solely responsible for (1) selecting the appropriate products for your application, (2) designing, validating, and testing your application, and (3) ensuring your application meets applicable standards, and any other safety, security, or other requirements. These resources are subject to change without notice. Renesas grants you permission to use these resources only for development of an application that uses Renesas products. Other reproduction or use of these resources is strictly prohibited. No license is granted to any other Renesas intellectual property or to any third party intellectual property. Renesas disclaims responsibility for, and you will fully indemnify Renesas and its representatives against, any claims, damages, costs, losses, or liabilities arising out of your use of these resources. Renesas' products are provided only subject to Renesas' Terms and Conditions of Sale or other applicable terms agreed to in writing. No use of any Renesas resources expands or otherwise alters any applicable warranties or warranty disclaimers for these products.

(Rev.1.0 Mar 2020)

Corporate Headquarters

TOYOSU FORESIA, 3-2-24 Toyosu,
Koto-ku, Tokyo 135-0061, Japan
www.renesas.com

Contact Information

For further information on a product, technology, the most up-to-date version of a document, or your nearest sales office, please visit:
www.renesas.com/contact/

Trademarks

Renesas and the Renesas logo are trademarks of Renesas Electronics Corporation. All trademarks and registered trademarks are the property of their respective owners.