

RC190xx

PCIe Gen5/6 Fanout Buffer Family with LOS

The RC190xx (RC19024A, RC19020A, RC19020A072, RC19016A, RC19013A, RC19008A, RC19004A) ultra-high performance fanout buffers support PCIe Gen5 and Gen6. They provide a Loss-Of-Signal (LOS) output for system monitoring and redundancy. The devices also incorporate Power Down Tolerant (PDT) and Flexible Startup Sequencing (FSS) features, easing system design. They can drive both source-terminated and double-terminated loads, operating up to 400MHz.

The family offers 4, 8, 13, 16, 20 and 24 Low-Power (LP) HCSL output pairs in 4 × 4 mm to 10 x 10mm packages. The RC190xx devices offer higher output counts in smaller packages compared to earlier buffer families. The buffers support both Common Clock (CC) and Independent Reference (IR) PCIe clock architectures.

Applications

- Cloud/High-performance Computing
- nVME Storage
- Networking
- Accelerators

Features

- PCIe Gen5 additive phase jitter: 6fs RMS
- PCIe Gen6 additive phase jitter: 4fs RMS
- DB2000Q additive phase jitter: 10fs RMS
- 12kHz to 20MHz additive phase jitter: 30fs RMS at 156.25MHz
- Power Down Tolerant (PDT) inputs
- Flexible Startup Sequencing (FSS)
- Automatic Clock Parking (ACP) upon loss of CLKIN
- Selectable output slew rate via pin or SMBus
- 4-wire Side-Band Interface supports high-speed serial output enable and device daisy-chaining
- 9 selectable SMBus addresses
- SMBus write protection features
- Spread-spectrum tolerant
- 85Ω or 100Ω (A100 suffix) output impedance
- CLKIN accepts HCSL or LVDS signal levels
- -40 to +105°C, 3.3V ±10% operation

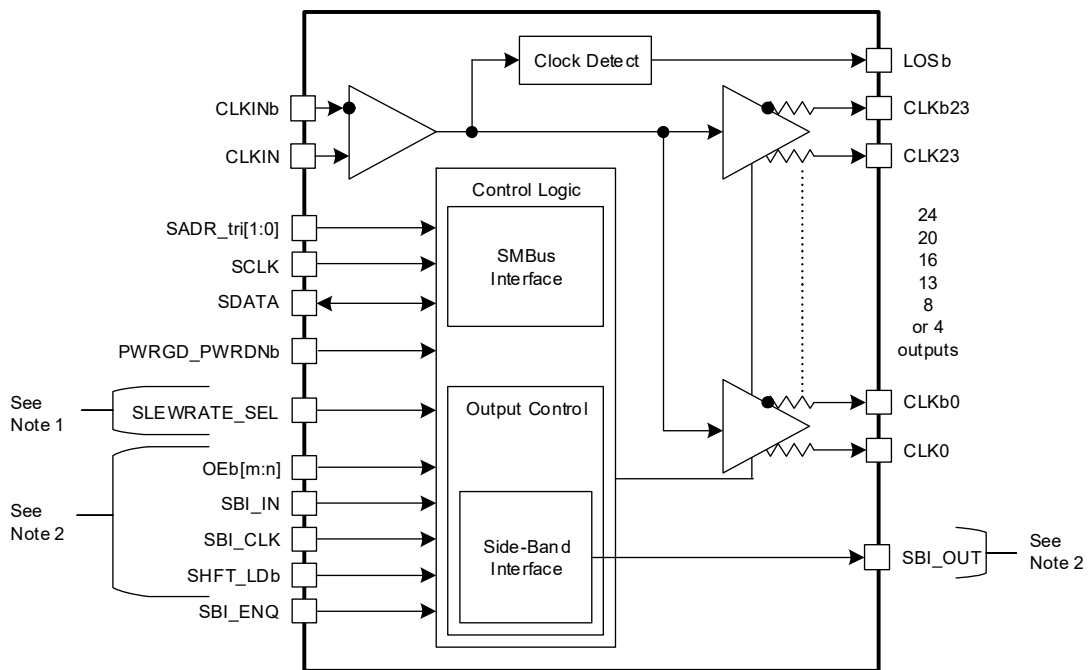

1. RC1901xA/0xA only. Other devices use SMBus.  
 2. On some devices the SBI is muxed with OEB pins. See pinouts for exact configurations. All devices have dedicated SBI\_ENQ pin.

Figure 1. RC190xx Block Diagram

## Contents

<b>1. Pin Information</b>	<b>4</b>
1.1 Signal Types	4
1.2 RC19024A Pin Assignments	5
1.2.1 RC19024A Pin Descriptions	5
1.3 RC19020A Pin Assignments	10
1.3.1 RC19020A Pin Descriptions	10
1.4 RC19020A072 Pin Configuration	14
1.4.1 RC19020A072 Pin Descriptions	14
1.5 RC19016A Pin Assignments	18
1.5.1 RC19016A Pin Descriptions	18
1.6 RC19013A Pin Assignments	22
1.6.1 RC19013A Pin Descriptions	22
1.7 RC19008A Pin Assignments	25
1.7.1 RC19008A Pin Descriptions	25
1.8 RC19004A Pin Assignments	28
1.8.1 RC19004A Pin Descriptions	28
<b>2. Specifications</b>	<b>30</b>
2.1 Absolute Maximum Ratings	30
2.2 ESD Ratings	30
2.3 Recommended Operation Conditions	31
2.4 Thermal Information	31
2.5 Electrical Characteristics	33
2.5.1 Phase Jitter	33
2.5.2 Output Frequencies, Startup Time, and LOS Timing	35
2.5.3 RC1902xA CLK AC/DC Output Characteristics	36
2.5.4 RC1901xA/RC1900xA CLK AC/DC Output Characteristics	39
2.5.5 Output-to-Output and Input-to-Output Skew	45
2.5.6 I/O Signals	46
2.5.7 Power Supply Current	47
2.5.8 CLKIN AC/DC Characteristics	51
2.5.9 SMBus Electrical Characteristics	51
2.5.10 Side-Band Interface	53
<b>3. Test Loads</b>	<b>54</b>
<b>4. General SMBus Serial Interface Information</b>	<b>56</b>
4.1 How to Write	56
4.2 How to Read	56
4.3 SMBus Bit Types	57
4.4 Write Lock Functionality	57
4.5 SMBus Address Decode	57
4.6 RC19024A SMBus Registers	58
4.7 RC19020A SMBus Registers	65
4.8 RC19020A072 SMBus Registers	70
4.9 RC1901xA/RC1900xA SMBus Registers	76
<b>5. Applications Information</b>	<b>81</b>
5.1 Inputs, Outputs, and Output Enable Control	81
5.1.1 Recommendations for Unused Inputs and Outputs	81

5.1.2	Differential CLKIN Configurations	81
5.1.3	Differential CLK Output Configurations	82
5.2	Power Down Tolerant Pins	83
5.3	Flexible Startup Sequencing	83
5.4	Loss of Signal and Automatic Clock Parking	84
5.5	Output Enable Control	85
5.5.1	SMBus Output Enable Bits	85
5.5.2	Output Enable (OEB) Pins	85
5.5.3	RC1902x Clock Buffer OEB Pins	85
5.5.4	Side-Band Interface (SBI)	88
5.5.5	Output Enable/Disable Priority	93
<b>6.</b>	<b>Package Outline Drawings</b>	<b>93</b>
<b>7.</b>	<b>Marking Diagrams</b>	<b>94</b>
7.1	RC1901xA/RC1900xA Marking Diagrams	94
7.2	RC1902xA Marking Diagrams	95
<b>8.</b>	<b>Ordering Information</b>	<b>96</b>
<b>9.</b>	<b>Revision History</b>	<b>97</b>

# 1. Pin Information

## 1.1 Signal Types

Term	Description
I	Input
O	Input
OD	Open Drain Output
I/O	Bi-Directional
PD	Pull-down
PU	Pull-up
Z	Tristate
D	Driven
X	Don't care
SE	Single ended
DIF	Differential
PWR	3.3 V power
GND	Ground
PDT	Power Down Tolerant: These signals must tolerate being driven when the device is powered down.

Note that some pins have both internal pull-up and pull-down resistors which bias the pins to VDD/2. Other pins are multi-mode and have an internal pull-up or internal pull-down depending on the mode.

## 1.2 RC19024A Pin Assignments

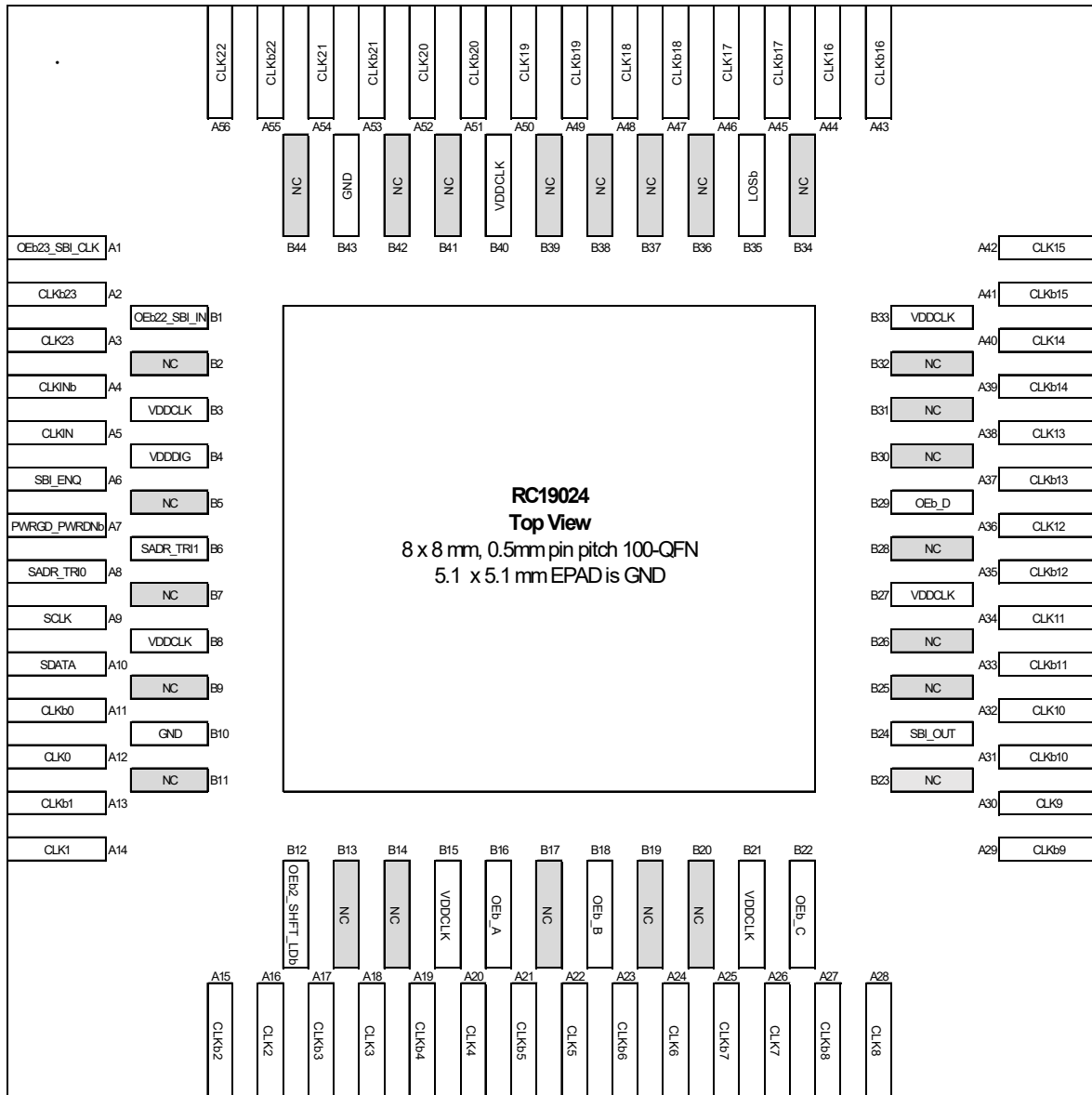

Figure 2. RC19024A 100-VFQFPN – Top View

### 1.2.1 RC19024A Pin Descriptions

Table 1. RC19024A Pin Descriptions

Pin Number	Pin Name	Pin Type	Description
A1	OEb23_SBI_CLK	I, SE, PD, PDT	Active low input for enabling output 23 or the clock pin for the SBI shift register. The function of this pin is controlled by the SBEN or SBI_ENQ pin. For more information, see <a href="#">Side-Band Interface (SBI)</a> . OE mode: 0 = enable output, 1 = disable output. Side-Band mode: Clocks data into the SBI on the rising edge.
A2	CLK23B	O, DIF	Complementary clock output.
A3	CLK23	O, DIF	True clock output.

Table 1. RC19024A Pin Descriptions (Cont.)

Pin Number	Pin Name	Pin Type	Description
A4	CLKINb	I, DIF, PDT	Complementary clock input.
A5	CLKIN	I, DIF, PDT	True clock input.
A6	SBI_ENQ	I, SE, PD, PDT	Input that selects function of pins that are multiplexed between OE and SBI functionality. SMBus output enable bits and non-multiplexed OE pins remain functional when SBI is enabled. This pin must be strapped to its desired state. It cannot dynamically change. 0 = SBI is disabled. Multiplexed pins function as output enables. 1 = SBI is enabled. Multiplexed pins function as SBI control pins.
A7	PWRGD_PWRDNb	I, SE, PU, PDT	Input notifies device to sample Latched inputs and start up on first high assertion. Low enters Power Down Mode, subsequent high assertions exit Power Down Mode. This pin has an internal pull-down.
A8	SADR_tri0	I, SE, PD, PU	SMBus address bit. This is a tri-level input that works in conjunction with other SADR pins, if present, to decode SMBus Addresses. See the <a href="#">SMBus Address Decode</a> table and the tri-level input thresholds in the electrical tables.
A9	SCLK	I, SE, PDT	Clock pin of SMBus interface.
A10	SDAT	I/O, OD, PDT	Data pin for SMBus interface.
A11	CLK0b	O, DIF	Complementary clock output.
A12	CLK0	O, DIF	True clock output.
A13	CLK1b	O, DIF	Complementary clock output.
A14	CLK1	O, DIF	True clock output.
A15	CLK2b	O, DIF	Complementary clock output.
A16	CLK2	O, DIF	True clock output.
A17	CLK3b	O, DIF	Complementary clock output.
A18	CLK3	O, DIF	True clock output.
A19	CLK4b	O, DIF	Complementary clock output.
A20	CLK4	O, DIF	True clock output.
A21	CLK5b	O, DIF	Complementary clock output.
A22	CLK5	O, DIF	True clock output.
A23	CLK6b	O, DIF	Complementary clock output.
A24	CLK6	O, DIF	True clock output.
A25	CLK7b	O, DIF	Complementary clock output.
A26	CLK7	O, DIF	True clock output.
A27	CLK8b	O, DIF	Complementary clock output.
A28	CLK8	O, DIF	True clock output.
A29	CLK9b	O, DIF	Complementary clock output.
A30	CLK9	O, DIF	True clock output.
A31	CLK10b	O, DIF	Complementary clock output.
A32	CLK10	O, DIF	True clock output.
A33	CLK11b	O, DIF	Complementary clock output.
A34	CLK11	O, DIF	True clock output.

Table 1. RC19024A Pin Descriptions (Cont.)

Pin Number	Pin Name	Pin Type	Description
A35	CLK12b	O, DIF	Complementary clock output.
A36	CLK12	O, DIF	True clock output.
A37	CLK13b	O, DIF	Complementary clock output.
A38	CLK13	O, DIF	True clock output.
A39	CLK14b	O, DIF	Complementary clock output.
A40	CLK14	O, DIF	True clock output.
A41	CLK15b	O, DIF	Complementary clock output.
A42	CLK15	O, DIF	True clock output.
A43	CLK16b	O, DIF	Complementary clock output.
A44	CLK16	O, DIF	True clock output.
A45	CLK17b	O, DIF	Complementary clock output.
A46	CLK17	O, DIF	True clock output.
A47	CLK18b	O, DIF	Complementary clock output.
A48	CLK18	O, DIF	True clock output.
A49	CLK19b	O, DIF	Complementary clock output.
A50	CLK19	O, DIF	True clock output.
A51	CLK20b	O, DIF	Complementary clock output.
A52	CLK20	O, DIF	True clock output.
A53	CLK21b	O, DIF	Complementary clock output.
A54	CLK21	O, DIF	True clock output.
A55	CLK22b	O, DIF	Complementary clock output.
A56	CLK22	O, DIF	True clock output.
B1	OEb22_SBI_IN	I, SE, PD, PDT	Active low input for enabling output 22 or the data pin for the Side-Band Interface. The function of this pin is controlled by the SBEN or SBI_ENQ pin. Refer to the <a href="#">Side-Band Interface (SBI)</a> section for details. OE mode: 0 = enable output, 1 = disable output. Side-Band mode: SBI shift register data input pin
B2	NC	NC	No Connect.
B3	VDDCLK	PWR	Clock Power supply.
B4	VDDDIG	PWR	Digital Power supply.
B5	NC	NC	No Connect
B6	SADR_tri1	I, SE, PD, PU	SMBus address bit. This is a tri-level input that works in conjunction with other SADR pins, if present, to decode SMBus Addresses. See the <a href="#">SMBus Address Decode</a> table and the tri-level input thresholds in the electrical tables.
B7	NC	NC	No Connect.
B8	VDDCLK	PWR	Clock Power supply.
B9	NC	NC	No Connect

Table 1. RC19024A Pin Descriptions (Cont.)

Pin Number	Pin Name	Pin Type	Description
B10	GND	GND	Connect to ground.
B11	NC	NC	No Connect.
B12	OEb2_SHFT_LDb	I, SE, PD, PDT	Active low input for enabling output 2 or SHFT_LDb pin for the Side-Band Interface. The function of this pin is controlled by the SBEN or SBI_ENQ pin. Refer to the <a href="#">Side-Band Interface (SBI)</a> section for details OE mode: 0 = Enable output, 1 = Disable output. Side-Band mode: 0 = Disable SBI shift register, 1 = Enable SBI shift register. A falling edge transfers SBI shift register contents to SBI output control register.
B13	NC	NC	No Connect.
B14	NC	NC	No Connect.
B15	VDDCLK	PWR	Clock Power supply.
B16	OEb_A	I, SE, PD, PDT	Active low input for enabling output group A. See the OEb_ASSIGNMENT[2:0] registers for details. 0 = enable output, 1 = disable output.
B17	NC	NC	No Connect.
B18	OEb_B	I, SE, PD, PDT	Active low input for enabling output group B. See the OEb_ASSIGNMENT registers for details. 0 = enable output, 1 = disable output.
B19	NC	NC	No Connect.
B20	NC	NC	No Connect.
B21	VDDCLK	PWR	Clock Power supply.
B22	OEb_C	I, SE, PD, PDT	Active low input for enabling output group C. See the OEb_ASSIGNMENT registers for details. 0 = enable output, 1 = disable output.
B23	NC	NC	No Connect.
B24	SBI_OUT	O, SE	Side-Band Interface data output.
B25	NC	NC	No Connect.
B26	NC	NC	No Connect.
B27	VDDCLK	PWR	Clock Power supply.
B28	NC	NC	No Connect.
B29	OEb_D	I, SE, PD, PDT	Active low input for enabling output group D. See the OEb_ASSIGNMENT registers for details. 0 = enable output, 1 = disable output.
B30	NC	NC	No Connect.
B31	NC	NC	No Connect.
B32	NC	NC	No Connect.
B33	VDDCLK	PWR	Clock Power supply.
B34	NC	NC	No Connect.



Table 1. RC19024A Pin Descriptions (Cont.)

Pin Number	Pin Name	Pin Type	Description
B35	LOSb	O, OD, PDT	Output indicating Loss of Input Signal. This pin is an open drain output and requires an external pull up resistor for proper functionality. A low output on this pin indicates a loss of signal on the input clock.
B36	NC	NC	No Connect.
B37	NC	NC	No Connect.
B38	NC	NC	No Connect.
B39	NC	NC	No Connect.
B40	VDDCLK	PWR	Clock Power supply.
B41	NC	NC	No Connect.
B42	NC	NC	No Connect.
B43	GND	GND	Connect to ground.
B44	NC	NC	No Connect.
N/A	EPAD	GND	Connect epad to ground.

### 1.3 RC19020A Pin Assignments

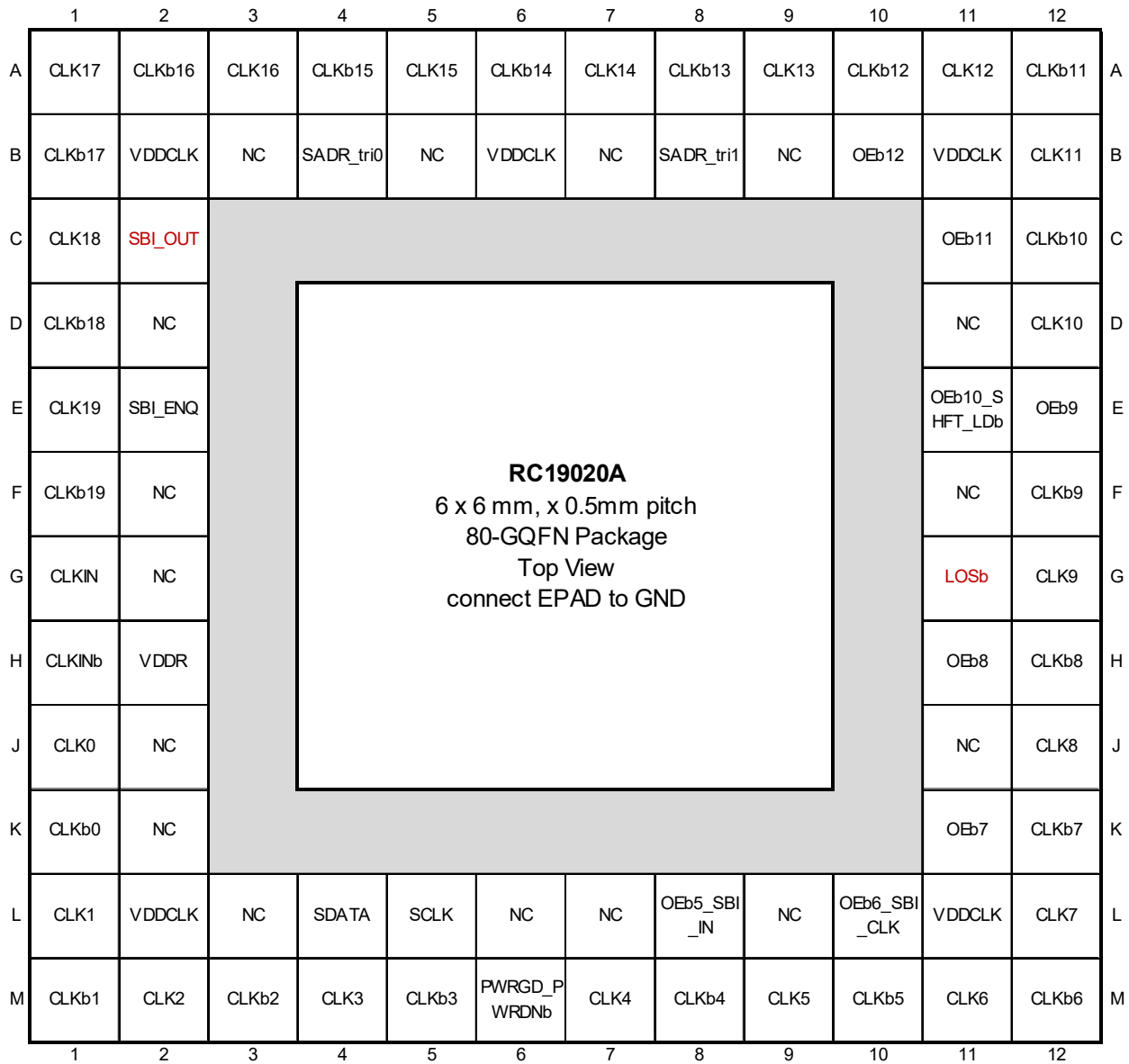

Figure 3. RC19020A 80-QQFN – Top View

The RC19020A is pin-compatible to the 9QXL2001B (DB2000QL) with SBI\_OUT and LOSb pins added to 9QXL2001B NC pins (C2 and G11).

#### 1.3.1 RC19020A Pin Descriptions

Table 2. RC19020A Pin Descriptions

Pin Number	Pin Name	Type	Description
A1	CLK17	O, DIF	True clock output.
A2	CLKb16	O, DIF	Complementary clock output.
A3	CLK16	O, DIF	True clock output.
A4	CLKb15	O, DIF	Complementary clock output.
A5	CLK15	O, DIF	True clock output.
A6	CLKb14	O, DIF	Complementary clock output.

Table 2. RC19020A Pin Descriptions (Cont.)

Pin Number	Pin Name	Type	Description
A7	CLK14	O, DIF	True clock output.
A8	CLKb13	O, DIF	Complementary clock output.
A9	CLK13	O, DIF	True clock output.
A10	CLKb12	O, DIF	Complementary clock output.
A11	CLK12	O, DIF	True clock output.
A12	CLKb11	O, DIF	Complementary clock output.
B1	CLKb17	O, DIF	Complementary clock output.
B2	VDDCLK	PWR	Power supply for clock outputs.
B3	NC	NC	No Connect.
B4	SADR_tri0	I, SE, PD, PU	SMBus address bit. This is a tri-level input that works in conjunction with other SADR pins, if present, to decode SMBus Addresses. See the <a href="#">SMBus Address Decode</a> table and the tri-level input thresholds in the electrical tables.
B5	NC	NC	No Connect.
B6	VDDCLK	PWR	Power supply for clock outputs.
B7	NC	NC	No Connect.
B8	SADR_tri1	I, SE, PD, PU	SMBus address bit. This is a tri-level input that works in conjunction with other SADR pins, if present, to decode SMBus Addresses. See the <a href="#">SMBus Address Decode</a> table and the tri-level input thresholds in the electrical tables.
B9	NC	NC	No Connect.
B10	OEb12	I, SE, PD, PDT	Active low input for enabling output 12. 0 = enable output, 1 = disable output.
B11	VDDCLK	PWR	Power supply for clock outputs.
B12	CLK11	O, DIF	True clock output.
C1	CLK18	O, DIF	True clock output.
C2	SBI_OUT	O, SE	Side-Band Interface data output.
C11	OEb11	I, SE, PD, PDT	Active low input for enabling output 11. 0 = enable output, 1 = disable output.
C12	CLKb10	O, DIF	Complementary clock output.
D1	CLKb18	O, DIF	Complementary clock output.
D2	NC	NC	No Connect.
D11	NC	NC	No Connect.
D12	CLK10	O, DIF	True clock output.
E1	CLK19	O, DIF	True clock output.
E2	SBI_ENQ	I, SE, PD, PDT	Input that selects function of pins that are multiplexed between OE and SBI functionality. SMBus output enable bits and non-multiplexed OE pins remain functional when SBI is enabled. This pin must be strapped to its desired state. It cannot dynamically change. 0 = SBI is disabled. Multiplexed pins function as output enables. 1 = SBI is enabled. Multiplexed pins function as SBI control pins.

Table 2. RC19020A Pin Descriptions (Cont.)

Pin Number	Pin Name	Type	Description
E11	OEb10_SHFT_LDb	I, SE, PD, PDT	Active low input for enabling output 10 or SHFT_LDb pin for the Side-Band Interface. The function of this pin is controlled by the SBEN or SBI_ENQ pin. For more information, see <a href="#">Side-Band Interface (SBI)</a> . OE mode: 0 = Enable output, 1 = Disable output. Side-Band mode: 0 = Disable SBI shift register, 1 = Enable SBI shift register. A falling edge transfers SBI shift register contents to SBI output control register.
E12	OEb9	I, SE, PU, PDT	Active low input for enabling output 9. 0 = enable output, 1 = disable output.
F1	CLKb19	O, DIF	Complementary clock output.
F2	NC	NC	No Connect.
F11	NC	NC	No Connect.
F12	CLKb9	O, DIF	Complementary clock output.
G1	CLKIN	I, DIF, PDT	True clock input.
G2	NC	NC	No Connect.
G11	LOSb	O, OD, PDT	Output indicating Loss of Input Signal. This pin is an open drain output and requires an external pull up resistor for proper functionality. A low output on this pin indicates a loss of signal on the input clock.
G12	CLK9	O, DIF	True clock output.
H1	CLKINb	I, DIF, PDT	Complementary clock input.
H2	VDDR	PWR	Power supply for clock input (receiver).
H11	OEb8	I, SE, PD, PDT	Active low input for enabling output 8. 0 = enable output, 1 = disable output.
H12	CLKb8	O, DIF	Complementary clock output.
J1	CLK0	O, DIF	True clock output.
J2	NC	NC	No Connect.
J11	NC	NC	No Connect.
J12	CLK8	O, DIF	True clock output.
K1	CLKb0	O, DIF	Complementary clock output.
K2	NC	NC	No Connect.
K11	OEb7	I, SE, PD, PDT	Active low input for enabling output 7. 0 = enable output, 1 = disable output.
K12	CLKb7	O, DIF	Complementary clock output.
L1	CLK1	O, DIF	True clock output.
L2	VDDCLK	PWR	Power supply for clock outputs.
L3	NC	NC	No Connect.
L4	SDATA	I/O, SE, OD, PDT	Data pin for SMBus interface.

Table 2. RC19020A Pin Descriptions (Cont.)

Pin Number	Pin Name	Type	Description
L5	SCLK	I, SE, PDT	Clock pin of SMBus interface.
L6	NC	NC	No Connect.
L7	NC	NC	No Connect.
L8	OEb5_SBI_IN	I, SE, PD, PDT	Active low input for enabling output 5 or the data pin for the Side-Band Interface. The function is this pin is controlled by the SBEN or SBI_ENQ pin. For more information, see <a href="#">Side-Band Interface (SBI)</a> . OE mode: 0 = Enable output, 1 = Disable output. Side-Band mode: SBI shift register data input pin
L9	NC	NC	No Connect
L10	OEb6_SBI_CLK	I, SE, PD, PDT	Active low input for enabling output 6 or the clock pin for the SBI shift register. The function is this pin is controlled by the SBI_ENQ pin. For more information, see <a href="#">Side-Band Interface (SBI)</a> . OE mode: 0 = Enable output, 1 = Disable output. Side-Band mode: Clocks data into the SBI shift register on the rising edge.
L11	VDDCLK	PWR	Power supply for clock outputs.
L12	CLK7	O, DIF	True clock output.
M1	CLKb1	O, DIF	Complementary clock output.
M2	CLK2	O, DIF	True clock output.
M3	CLKb2	O, DIF	Complementary clock output.
M4	CLK3	O, DIF	True clock output.
M5	CLKb3	O, DIF	Complementary clock output.
M6	PWRGD_PWRDNb	I, SE, PU, PDT	Input notifies device to sample latched inputs and start up on first high assertion. Low enters Power Down Mode, subsequent high assertions exit Power Down Mode.
M7	CLK4	O, DIF	True clock output.
M8	CLKb4	O, DIF	Complementary clock output.
M9	CLK5	O, DIF	True clock output.
M10	CLKb5	O, DIF	Complementary clock output.
M11	CLK6	O, DIF	True clock output.
M12	CLKb6	O, DIF	Complementary clock output.
N/A	EPAD	GND	Connect epad to ground.

## 1.4 RC19020A072 Pin Configuration

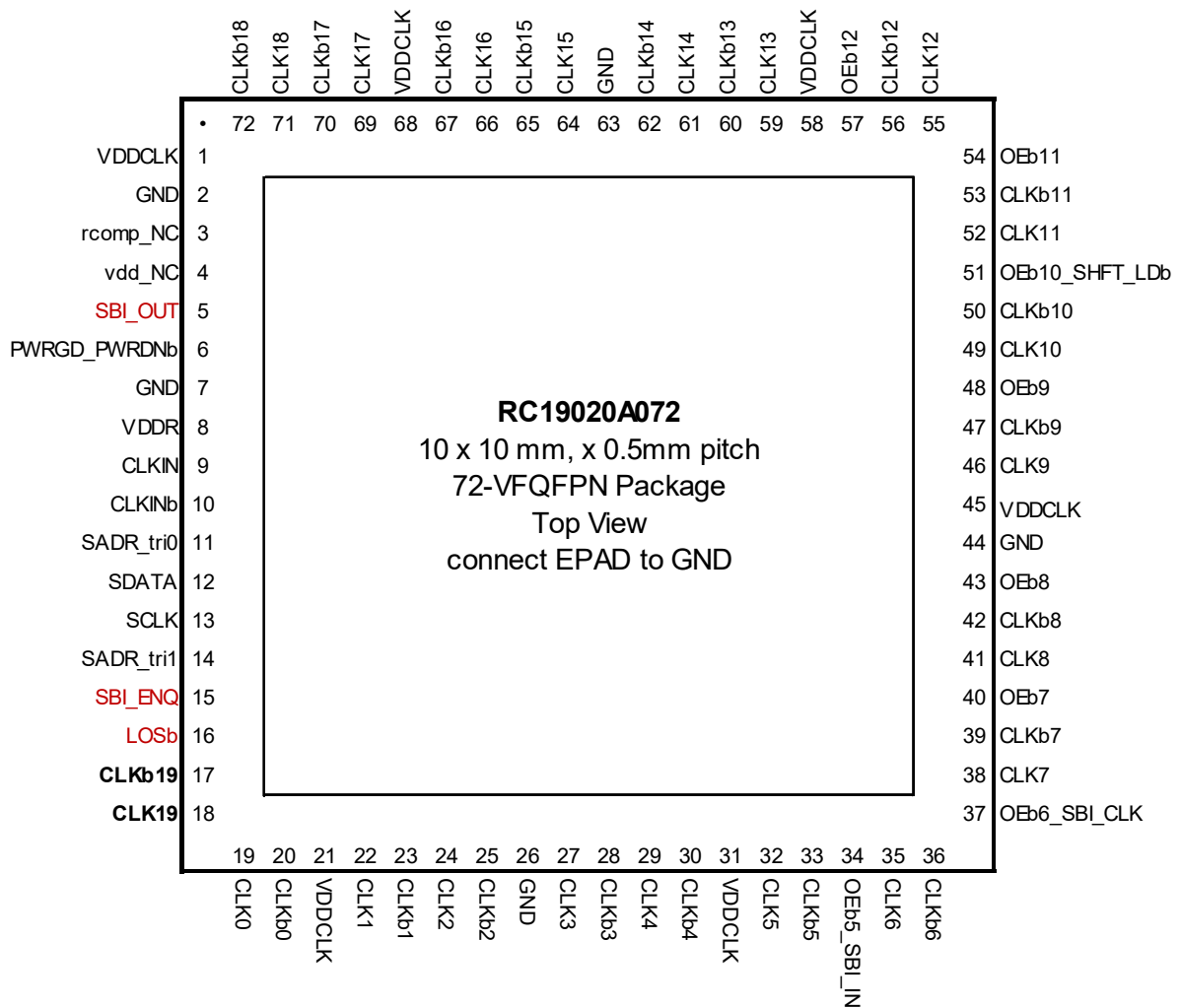

**Figure 4. RC19020A072 72-VFQFPN – Top View**

The RC19020A072 is pin-compatible to the 9QXL2000B (DB2000Q) with the SBI\_OUT, SBI\_ENQ and LOSb pins placed on 9QXL2000 NC pins (5, 15 and 16).

### 1.4.1 RC19020A072 Pin Descriptions

**Table 3. RC19020A072 Pin Descriptions**

Pin Number	Pin Name	Type	Description
1	VDDCLK	PWR	Power supply for clock outputs.
2	GND	GND	Ground pin.
3	rcomp_NC	N/A	The DB2000Q specification calls this pin RCOMP. This pin is a true No Connect on the Renesas 9QXL2000 device, since it is not needed. Any existing connections on the board may remain to support non-IDT DB2000Q devices.
4	vdd_NC	NC	The DB2000Q specification calls this pin VDD. This pin is a true No Connect on the IDT 9QXL2000 device, since it is not needed. Any existing connections on the board may remain to support non-IDT DB2000Q devices.
5	SBI_OUT	O, SE	Side-Band Interface data output.

Table 3. RC19020A072 Pin Descriptions (Cont.)

Pin Number	Pin Name	Type	Description
6	PWRGD_PWRDNb	I, SE, PU, PDT	Input notifies device to sample latched inputs and start up on first high assertion. Low enters Power Down Mode, subsequent high assertions exit Power Down Mode.
7	GND	GND	Ground pin.
8	VDDR	PWR	Power supply for clock input (receiver).
9	CLKIN	I, DIF, PDT	True clock input.
10	CLKINb	I, DIF, PDT	Complementary clock input.
11	SADR_tri0	I, SE, PD, PU	SMBus address bit. This is a tri-level input that works in conjunction with other SADR pins, if present, to decode SMBus Addresses. See the <a href="#">SMBus Address Decode</a> table and refer to the tri-level input thresholds in the electrical tables.
12	SDATA	I/O, SE, OD, PDT	Data pin for SMBus interface.
13	SCLK	I, SE, PDT	Clock pin of SMBus interface.
14	SADR_tri1	I, SE, PD, PU	SMBus address bit. This is a tri-level input that works in conjunction with other SADR pins, if present, to decode SMBus Addresses. See the <a href="#">SMBus Address Decode</a> table and refer to the tri-level input thresholds in the electrical tables.
15	SBI_ENQ	I, SE, PD, PDT	Input that selects function of pins that are multiplexed between OE and SBI functionality. SMBus output enable bits and non-multiplexed OE pins remain functional when SBI is enabled. This pin must be strapped to its desired state. It cannot dynamically change. 0 = SBI is disabled. Multiplexed pins function as output enables. 1 = SBI is enabled. Multiplexed pins function as SBI control pins.
16	LOSb	O, OD, PDT	Output indicating Loss of Input Signal. This pin is an open drain output and requires an external pull up resistor for proper functionality. A low output on this pin indicates a loss of signal on the input clock.
17	CLKb19	O, DIF	Complementary clock output.
18	CLK19	O, DIF	True clock output.
19	CLK0	O, DIF	True clock output.
20	CLKb0	O, DIF	Complementary clock output.
21	VDDCLK	PWR	Power supply for clock outputs.
22	CLK1	O, DIF	True clock output.
23	CLKb1	O, DIF	Complementary clock output.
24	CLK2	O, DIF	True clock output.
25	CLKb2	O, DIF	Complementary clock output.
26	GND	GND	Ground pin.
27	CLK3	O, DIF	True clock output.
28	CLKb3	O, DIF	Complementary clock output.
29	CLK4	O, DIF	True clock output.
30	CLKb4	O, DIF	Complementary clock output.
31	VDDCLK	PWR	Power supply for clock outputs.

Table 3. RC19020A072 Pin Descriptions (Cont.)

Pin Number	Pin Name	Type	Description
32	CLK5	O, DIF	True clock output.
33	CLKb5	O, DIF	Complementary clock output.
34	OEb5_SBI_IN	I, SE, PU, PD, PDT	Active low input for enabling output 5 or the data pin for the Side-Band Interface. The function of this pin is controlled by the SBEN or SBI_ENQ pin. Refer to the <a href="#">Side-Band Interface (SBI)</a> section for details. OE mode with internal pull-up: 0 = enable output, 1 = disable output. Side-Band mode with internal pull down: SBI shift register data input pin
35	CLK6	O, DIF	True clock output.
36	CLKb6	O, DIF	Complementary clock output.
37	OEb6_SBI_CLK	I, SE, PU, PDT	Active low input for enabling output 6 or the clock pin for the SBI shift register. The function of this pin is controlled by the SBEN or SBI_ENQ pin. Refer to the <a href="#">Side-Band Interface (SBI)</a> section for details. OE mode with internal pull-up: 0 = enable output, 1 = disable output. Side-Band mode with internal pull down: Clocks data into the SBI shift register on the rising edge.
38	CLK7	O, DIF	True clock output.
39	CLKb7	O, DIF	Complementary clock output.
40	OEb7	I, SE, PU, PDT	Active low input for enabling output 7. 0 = enable output, 1 = disable output.
41	CLK8	O, DIF	True clock output.
42	CLKb8	O, DIF	Complementary clock output.
43	OEb8	I, SE, PU, PDT	Active low input for enabling output 8. 0 = enable output, 1 = disable output.
44	GND	GND	Ground pin.
45	VDDCLK	PWR	Power supply for clock outputs.
46	CLK9	O, DIF	True clock output.
47	CLKb9	O, DIF	Complementary clock output.
48	OEb9	I, SE, PDT, PU	Active low input for enabling output 9. 0 = enable output, 1 = disable output.
49	CLK10	O, DIF	True clock output.
50	CLKb10	O, DIF	Complementary clock output.
51	OEb10_SHFT_LDb	I, SE, PU, PD, PDT	Active low input for enabling output 10 or SHFT_LDb pin for the Side-Band Interface. The function of this pin is controlled by the SBEN or SBI_ENQ pin. Refer to the <a href="#">Side-Band Interface (SBI)</a> section for details. OE mode with internal pull-up: 0 = enable output, 1 = disable output. Side-Band Mode with internal pull-down: 0 = Disable SBI shift register, 1 = Enable SBI shift register. A falling edge transfers SBI shift register contents to SBI output control register.
52	CLK11	O, DIF	True clock output.



Table 3. RC19020A072 Pin Descriptions (Cont.)

Pin Number	Pin Name	Type	Description
53	CLKb11	O, DIF	Complementary clock output.
54	OEb11	I, SE, PU, PDT	Active low input for enabling output 11. 0 = enable output, 1 = disable output.
55	CLK12	O, DIF	True clock output.
56	CLKb12	O, DIF	Complementary clock output.
57	OEb12	I, SE, PU, PDT	Active low input for enabling output 12. 0 = enable output, 1 = disable output.
58	VDDCLK	PWR	Power supply for clock outputs.
59	CLK13	O, DIF	True clock output.
60	CLKb13	O, DIF	Complementary clock output.
61	CLK14	O, DIF	True clock output.
62	CLKb14	O, DIF	Complementary clock output.
63	GND	GND	Ground pin.
64	CLK15	O, DIF	True clock output.
65	CLKb15	O, DIF	Complementary clock output.
66	CLK16	O, DIF	True clock output.
67	CLKb16	O, DIF	Complementary clock output.
68	VDDCLK	PWR	Power supply for clock outputs.
69	CLK17	O, DIF	True clock output.
70	CLKb17	O, DIF	Complementary clock output.
71	CLK18	O, DIF	True clock output.
72	CLKb18	O, DIF	Complementary clock output.
73	EPAD	GND	Connect EPAD to Ground.

## 1.5 RC19016A Pin Assignments

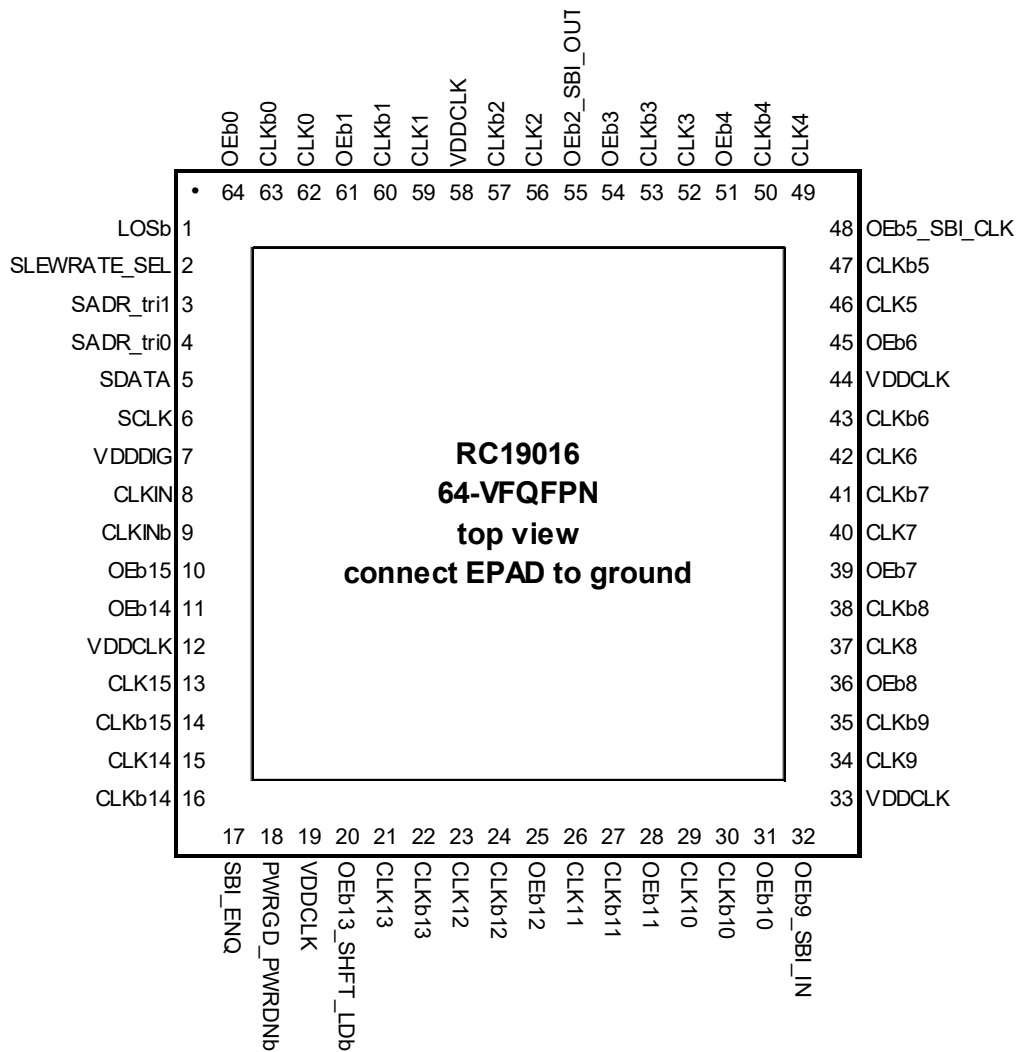

Figure 5. RC19016A 64-VFQFPN – Top View

### 1.5.1 RC19016A Pin Descriptions

Table 4. RC19016A Pin Descriptions

Pin Number	Pin Name	Type	Description
1	LOSb	O, OD, PDT	Output indicating Loss of Input Signal. This pin is an open-drain output and requires an external pull-up resistor for proper functionality. A low output on this pin indicates a loss of signal on the input clock.
2	SLEWRATE_SEL	I, SE, PU, PDT	Input to select default slew rate of the outputs. 0 = Slow Slew Rate, 1 = Fast Slew Rate.
3	SADR_tri1	I, SE, PD, PU	SMBus address bit. This is a tri-level input that works in conjunction with other SADR pins, if present, to decode SMBus Addresses. See the <a href="#">SMBus Address Decode</a> table and the tri-level input thresholds in the electrical tables.
4	SADR_tri0	I, SE, PD, PU	SMBus address bit. This is a tri-level input that works in conjunction with other SADR pins, if present, to decode SMBus Addresses. See the <a href="#">SMBus Address Decode</a> table and the tri-level input thresholds in the electrical tables.
5	SDATA	I/O, SE, OD	Data pin for SMBus interface.

Table 4. RC19016A Pin Descriptions (Cont.)

Pin Number	Pin Name	Type	Description
6	SCLK	I, SE	Clock pin of SMBus interface.
7	VDDDIG	PWR	Digital power.
8	CLKIN	I, DIF	True clock input.
9	CLKINb	I, DIF	Complementary clock input.
10	OEB15	I, SE, PD, PDT	Active low input for enabling output 15. 0 = Enable output, 1 = Disable output.
11	OEB14	I, SE, PD, PDT	Active low input for enabling output 14. 0 = Enable output, 1 = Disable output.
12	VDDCLK	PWR	Clock power supply.
13	CLK15	O, DIF	True clock output.
14	CLKb15	O, DIF	Complementary clock output.
15	CLK14	O, DIF	True clock output.
16	CLKb14	O, DIF	Complementary clock output.
17	SBI_ENQ	I, SE, PD, PDT	Input that selects function of pins that are multiplexed between OE and SBI functionality. SMBus output enable bits and non-multiplexed OE pins remain functional when SBI is enabled. This pin must be strapped to its desired state. It cannot dynamically change. 0 = SBI is disabled. Multiplexed pins function as output enables. 1 = SBI is enabled. Multiplexed pins function as SBI control pins.
18	PWRGD_PWRDNb	I, SE, PU, PDT	Input notifies device to sample latched inputs and start up on first high assertion. Low enters Power Down Mode, subsequent high assertions exit Power Down Mode.
19	VDDCLK	PWR	Clock power supply.
20	OEB13_SHFT_LDb	I, SE, PD, PDT	Active low input for enabling output 13 or SHFT_LDb pin for the Side-Band Interface. The function of this pin is controlled by the SBI_ENQ pin. For more information, see <a href="#">Side-Band Interface (SBI)</a> . OE mode: 0 = Enable output, 1 = Disable output. Side-Band mode: 0 = Disable SBI shift register, 1 = Enable SBI shift register. A falling edge transfers SBI shift register contents to SBI output control register.
21	CLK13	O, DIF	True clock output.
22	CLKb13	O, DIF	Complementary clock output.
23	CLK12	O, DIF	True clock output.
24	CLKb12	O, DIF	Complementary clock output.
25	OEB12	I, SE, PD, PDT	Active low input for enabling output 12. 0 = Enable output, 1 = Disable output.
26	CLK11	O, DIF	True clock output.
27	CLKb11	O, DIF	Complementary clock output.
28	OEB11	I, SE, PD, PDT	Active low input for enabling output 11. 0 = Enable output, 1 = Disable output.
29	CLK10	O, DIF	True clock output.
30	CLKb10	O, DIF	Complementary clock output.

Table 4. RC19016A Pin Descriptions (Cont.)

Pin Number	Pin Name	Type	Description
31	OEb10	I, SE, PD, PDT	Active low input for enabling output 10. 0 = Enable output, 1 = Disable output.
32	OEb9_SBI_IN	I, SE, PD, PDT	Active low input for enabling output 9 or the data pin for the Side-Band Interface. The function of this pin is controlled by the SBI_ENQ pin. For more information, see <a href="#">Side-Band Interface (SBI)</a> . OE mode: 0 = Enable output, 1 = Disable output. Side-Band mode: SBI shift register data input pin
33	VDDCLK	PWR	Clock Power supply.
34	CLK9	O, DIF	True clock output.
35	CLKb9	O, DIF	Complementary clock output.
36	OEb8	I, SE, PD, PDT	Active low input for enabling output 8. 0 = Enable output, 1 = Disable output.
37	CLK8	O, DIF	True clock output.
38	CLKb8	O, DIF	Complementary clock output.
39	OEb7	I, SE, PD, PDT	Active low input for enabling output 7. 0 = Enable output, 1 = Disable output.
40	CLK7	O, DIF	True clock output.
41	CLKb7	O, DIF	Complementary clock output.
42	CLK6	O, DIF	True clock output.
43	CLKb6	O, DIF	Complementary clock output.
44	VDDCLK	PWR	Clock Power supply.
45	OEb6	I, SE, PD, PDT	Active low input for enabling output 6. 0 = Enable output, 1 = Disable output.
46	CLK5	O, DIF	True clock output.
47	CLKb5	O, DIF	Complementary clock output.
48	OEb5_SBI_CLK	I, SE, PD, PDT	Active low input for enabling output 5 or the clock pin for the SBI shift register. The function of this pin is controlled by the SBI_ENQ pin. For more information, see <a href="#">Side-Band Interface (SBI)</a> . OE mode: 0 = Enable output, 1 = Disable output. Side-Band mode: Clocks data into the SBI on the rising edge.
49	CLK4	O, DIF	True clock output.
50	CLKb4	O, DIF	Complementary clock output.
51	OEb4	I, SE, PD, PDT	Active low input for enabling output 4 0 = Enable output, 1 = Disable output.
52	CLK3	O, DIF	True clock output.
53	CLKb3	O, DIF	Complementary clock output.
54	OEb3	I, SE, PD, PDT	Active low input for enabling output 3. 0 = Enable output, 1 = Disable output.

Table 4. RC19016A Pin Descriptions (Cont.)

Pin Number	Pin Name	Type	Description
55	OEb2_SBI_OUT	I, SE, PD	Active low input for enabling output 2 or the SBI shift register data output. The function of this pin is controlled by the SBI_ENQ. For more information, see <a href="#">Side-Band Interface (SBI)</a> . <b>Note: This pin is NOT PDT.</b> OE mode: 0 = Enable output, 1 = Disable output. Side-Band mode: SBI shift register data output.
56	CLK2	O, DIF	True clock output.
57	CLKb2	O, DIF	Complementary clock output.
58	VDDCLK	PWR	Clock Power supply.
59	CLK1	O, DIF	True clock output.
60	CLKb1	O, DIF	Complementary clock output.
61	OEb1	I, SE, PD, PDT	Active low input for enabling output 1. 0 = Enable output, 1 = Disable output.
62	CLK0	O, DIF	True clock output.
63	CLKb0	O, DIF	Complementary clock output.
64	OEb0	I, SE, PD, PDT	Active low input for enabling output 0. 0 = Enable output, 1 = Disable output.
65	EPAD	GND	Ground pin.

## 1.6 RC19013A Pin Assignments

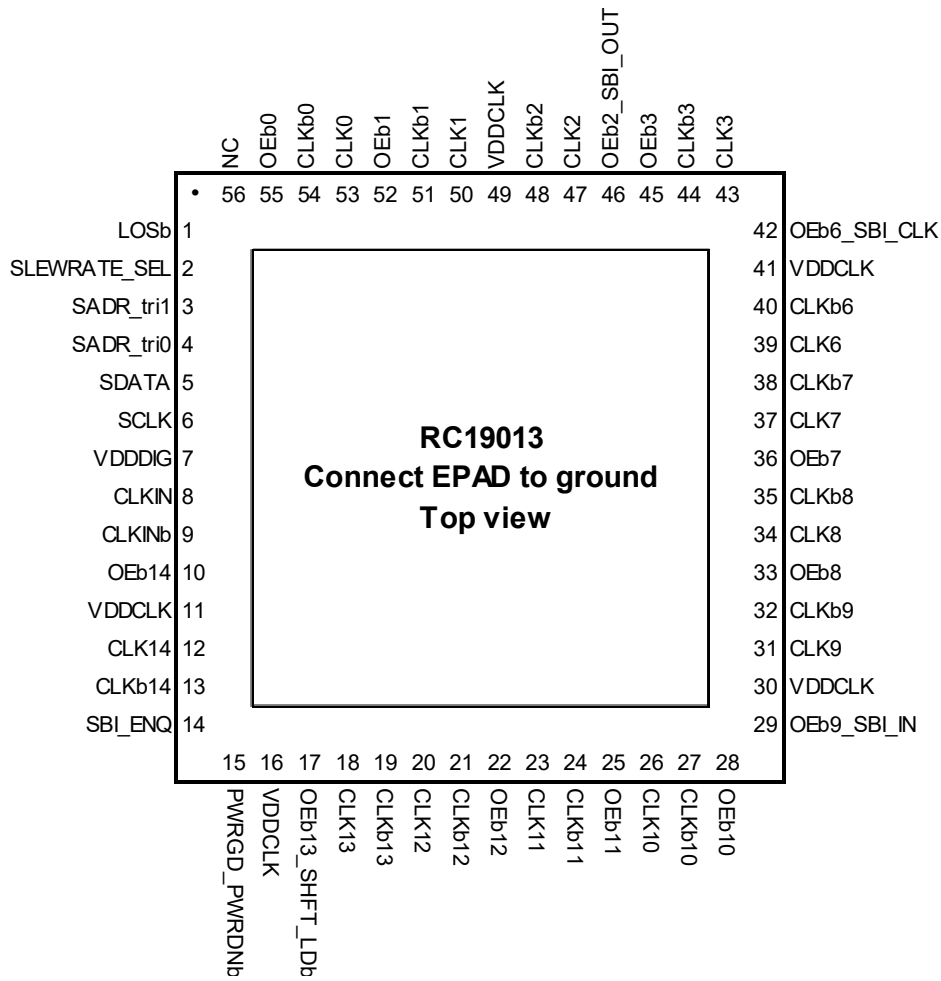

Figure 6. RC19013A 56-VFQFPN – Top View

### 1.6.1 RC19013A Pin Descriptions

Table 5. RC19013A Pin Descriptions

Pin Number	Pin Name	Type	Description
1	LOSb	O, OD, PDT	Output indicating Loss of Input Signal. This pin is an open-drain output and requires an external pull-up resistor for proper functionality. A low output on this pin indicates a loss of signal on the input clock.
2	SLEWRATE_SEL	I, SE, PU, PDT	Input to select default slew rate of the outputs. 0 = Slow Slew Rate, 1 = Fast Slew Rate.
3	SADR_tri1	I, SE, PD, PU	SMBus address bit. This is a tri-level input that works in conjunction with other SADR pins, if present, to decode SMBus Addresses. See the <a href="#">SMBus Address Decode</a> table and the tri-level input thresholds in the electrical tables.
4	SADR_tri0	I, SE, PD, PU	SMBus address bit. This is a tri-level input that works in conjunction with other SADR pins, if present, to decode SMBus Addresses. See the <a href="#">SMBus Address Decode</a> table and the tri-level input thresholds in the electrical tables.
5	SDATA	I/O, SE, OD	Data pin for SMBus interface.
6	SCLK	I, SE	Clock pin of SMBus interface.
7	VDDDIG	PWR	Digital power.

Table 5. RC19013A Pin Descriptions (Cont.)

Pin Number	Pin Name	Type	Description
8	CLKIN	I, DIF	True clock input.
9	CLKINb	I, DIF	Complementary clock input.
10	OEB14	I, SE, PD, PDT	Active low input for enabling output 14. 0 = Enable output, 1 = Disable output.
11	VDDCLK	PWR	Clock power supply.
12	CLK14	O, DIF	True clock output.
13	CLKb14	O, DIF	Complementary clock output.
14	SBI_ENQ	I, SE, PD, PDT	Input that selects function of pins that are multiplexed between OE and SBI functionality. SMBus output enable bits and non-multiplexed OE pins remain functional when SBI is enabled. This pin must be strapped to its desired state. It cannot dynamically change. 0 = SBI is disabled. Multiplexed pins function as output enables. 1 = SBI is enabled. Multiplexed pins function as SBI control pins.
15	PWRGD_PWRDNb	I, SE, PU, PDT	Input notifies device to sample latched inputs and start up on first high assertion. Low enters Power Down Mode, subsequent high assertions exit Power Down Mode.
16	VDDCLK	PWR	Clock Power supply.
17	OEB13_SHFT_LDb	I, SE, PD, PDT	Active low input for enabling output 13 or SHFT_LDb pin for the Side-Band Interface. The function of this pin is controlled by the SBI_ENQ pin. For more information, see <a href="#">Side-Band Interface (SBI)</a> . OE mode: 0 = Enable output, 1 = Disable output. Side-Band mode: 0 = Disable SBI shift register, 1 = Enable SBI shift register. A falling edge transfers SBI shift register contents to SBI output control register.
18	CLK13	O, DIF	True clock output.
19	CLKb13	O, DIF	Complementary clock output.
20	CLK12	O, DIF	True clock output.
21	CLKb12	O, DIF	Complementary clock output.
22	OEB12	I, SE, PD, PDT	Active low input for enabling output 12. 0 = Enable output, 1 = Disable output.
23	CLK11	O, DIF	True clock output.
24	CLKb11	O, DIF	Complementary clock output.
25	OEB11	I, SE, PD, PDT	Active low input for enabling output 11. 0 = Enable output, 1 = Disable output.
26	CLK10	O, DIF	True clock output.
27	CLKb10	O, DIF	Complementary clock output.
28	OEB10	I, SE, PD, PDT	Active low input for enabling output 10. 0 = Enable output, 1 = Disable output.

Table 5. RC19013A Pin Descriptions (Cont.)

Pin Number	Pin Name	Type	Description
29	OEb9_SBI_IN	I, SE, PD, PDT	Active low input for enabling output 9 or the data pin for the Side-Band Interface. The function is this pin is controlled by the SBI_ENQ pin. For more information, see <a href="#">Side-Band Interface (SBI)</a> . OE mode: 0 = Enable output, 1 = Disable output. Side-Band mode: SBI shift register data input pin
30	VDDCLK	PWR	Clock power supply.
31	CLK9	O, DIF	True clock output.
32	CLKb9	O, DIF	Complementary clock output.
33	OEb8	I, SE, PD, PDT	Active low input for enabling output 8. 0 = Enable output, 1 = Disable output.
34	CLK8	O, DIF	True clock output.
35	CLKb8	O, DIF	Complementary clock output.
36	OEb7	I, SE, PD, PDT	Active low input for enabling output 7. 0 = Enable output, 1 = Disable output.
37	CLK7	O, DIF	True clock output.
38	CLKb7	O, DIF	Complementary clock output.
39	CLK6	O, DIF	True clock output.
40	CLKb6	O, DIF	Complementary clock output.
41	VDDCLK	PWR	Clock power supply.
42	OEb6_SBI_CLK	I, SE, PD, PDT	Active low input for enabling output 6 or the clock pin for the SBI shift register. The function is this pin is controlled by the SBI_ENQ pin. For more information, see <a href="#">Side-Band Interface (SBI)</a> . OE mode: 0 = Enable output, 1 = Disable output. Side-Band mode: Clocks data into the SBI shift register on the rising edge.
43	CLK3	O, DIF	True clock output.
44	CLKb3	O, DIF	Complementary clock output.
45	OEb3	I, SE, PD, PDT	Active low input for enabling output 3. 0 = Enable output, 1 = Disable output.
46	OEb2_SBI_OUT	I, SE, PD	Active low input for enabling output 2 or the SBI shift register data output. The function is this pin is controlled by the SBI_ENQ pin. For more information, see <a href="#">Side-Band Interface (SBI)</a> . <b>Note: This pin is NOT PDT.</b> OE mode: 0 = Enable output, 1 = Disable output. Side-Band mode: SBI shift register data output.
47	CLK2	O, DIF	True clock output.
48	CLKb2	O, DIF	Complementary clock output.
49	VDDCLK	PWR	Clock power supply.
50	CLK1	O, DIF	True clock output.



Table 5. RC19013A Pin Descriptions (Cont.)

Pin Number	Pin Name	Type	Description
51	CLKb1	O, DIF	Complementary clock output.
52	OEb1	I, SE, PD, PDT	Active low input for enabling output 1. 0 = Enable output, 1 = Disable output.
53	CLK0	O, DIF	True clock output.
54	CLKb0	O, DIF	Complementary clock output.
55	OEb0	I, SE, PD, PDT	Active low input for enabling output 0. 0 = Enable output, 1 = Disable output.
56	NC	NC	No connect.
57	EPAD	GND	Connect epad to ground.

### 1.7 RC19008A Pin Assignments

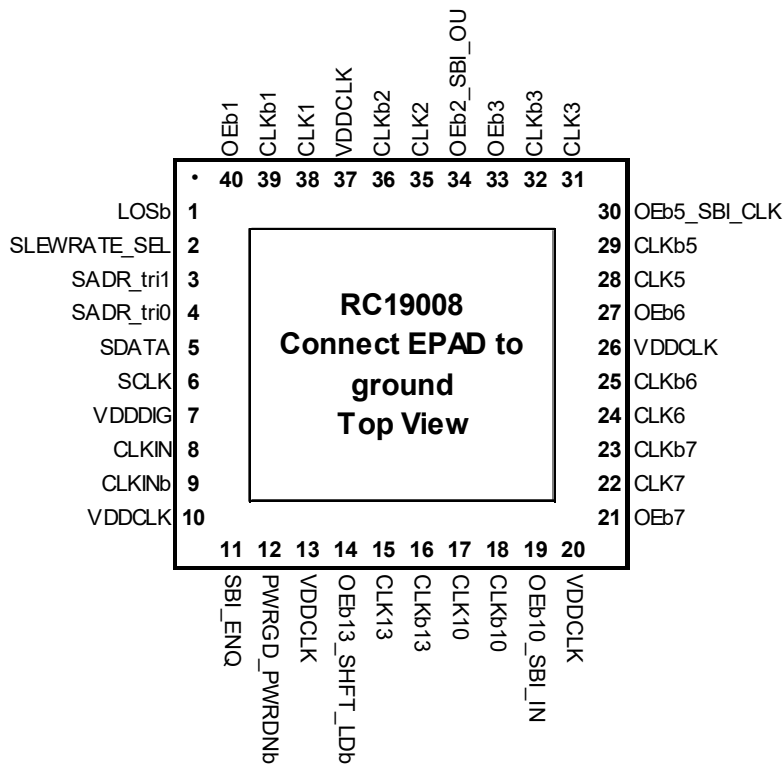

Figure 7. RC19008A 40-VFQFPN – Top View

#### 1.7.1 RC19008A Pin Descriptions

Table 6. RC19008A Pin Descriptions

Pin Number	Pin Name	Type	Description
1	LOSb	O, OD, PDT	Output indicating Loss of Input Signal. This pin is an open-drain output and requires an external pull-up resistor for proper functionality. A low output on this pin indicates a loss of signal on the input clock.
2	SLEWRATE_SEL	I, SE, PU, PDT	Input to select default slew rate of the outputs. 0 = Slow Slew Rate, 1 = Fast Slew Rate.

Table 6. RC19008A Pin Descriptions (Cont.)

Pin Number	Pin Name	Type	Description
3	SADR_tri1	I, SE, PD, PU	SMBus address bit. This is a tri-level input that works in conjunction with other SADR pins, if present, to decode SMBus Addresses. See the <a href="#">SMBus Address Decode</a> table and tri-level input thresholds in the electrical tables.
4	SADR_tri0	I, SE, PD, PU	SMBus address bit. This is a tri-level input that works in conjunction with other SADR pins, if present, to decode SMBus Addresses. See the <a href="#">SMBus Address Decode</a> table and tri-level input thresholds in the electrical tables.
5	SDATA	I/O, SE, OD	Data pin for SMBus interface.
6	SCLK	I, SE	Clock pin of SMBus interface.
7	VDDDIG	PWR	Digital power.
8	CLKIN	I, DIF	True clock input.
9	CLKINb	I, DIF	Complementary clock input.
10	VDDCLK	PWR	Clock Power supply.
11	SBI_ENQ	I, SE, PD, PDT	Input that selects function of pins that are multiplexed between OE and SBI functionality. SMBus output enable bits and non-multiplexed OE pins remain functional when SBI is enabled. This pin must be strapped to its desired state. It cannot dynamically change. 0 = SBI is disabled. Multiplexed pins function as output enables. 1 = SBI is enabled. Multiplexed pins function as SBI control pins.
12	PWRGD_PWRDNb	I, SE, PU, PDT	Input notifies device to sample latched inputs and start up on first high assertion. Low enters Power Down Mode, subsequent high assertions exit Power Down Mode.
13	VDDCLK	PWR	Clock power supply.
14	OEb13_SHFT_LDb	I, SE, PD, PDT	Active low input for enabling output 13 or SHFT_LDb pin for the Side-Band Interface. The function of this pin is controlled by the SBI_ENQ pin. For more information, see <a href="#">Side-Band Interface (SBI)</a> . OE mode: 0 = Enable output, 1 = Disable output. Side-Band mode: 0 = Disable SBI shift register, 1 = Enable SBI shift register. A falling edge transfers SBI shift register contents to SBI output control register.
15	CLK13	O, DIF	True clock output.
16	CLKb13	O, DIF	Complementary clock output.
17	CLK10	O, DIF	True clock output.
18	CLKb10	O, DIF	Complementary clock output.
19	OEb10_SBI_IN	I, SE, PD, PDT	Active low input for enabling output 10 or the data pin for the Side-Band Interface. The function of this pin is controlled by the SBI_ENQ pin. For more information, see <a href="#">Side-Band Interface (SBI)</a> . OE mode: 0 = Enable output, 1 = Disable output. Side-Band mode: SBI shift-register data input.
20	VDDCLK	PWR	Clock power supply.
21	OEb7	I, SE, PD, PDT	Active low input for enabling output 7. 0 = Enable output, 1 = Disable output.

Table 6. RC19008A Pin Descriptions (Cont.)

Pin Number	Pin Name	Type	Description
22	CLK7	O, DIF	True clock output.
23	CLKb7	O, DIF	Complementary clock output.
24	CLK6	O, DIF	True clock output.
25	CLKb6	O, DIF	Complementary clock output.
26	VDDCLK	PWR	Clock Power supply.
27	OEb6	I, SE, PD, PDT	Active low input for enabling output 6. 0 = Enable output, 1 = Disable output.
28	CLK5	O, DIF	True clock output.
29	CLKb5	O, DIF	Complementary clock output.
30	OEb5_SBI_CLK	I, SE, PD, PDT	Active low input for enabling output 5 or the clock pin for the SBI shift register. The function is this pin is controlled by the SBI_ENQ pin. For more information, see <a href="#">Side-Band Interface (SBI)</a> . OE mode: 0 = Enable output, 1 = Disable output. Side-Band mode: Clocks data into the SBI on the rising edge.
31	CLK3	O, DIF	True clock output.
32	CLKb3	O, DIF	Complementary clock output.
33	OEb3	I, SE, PD, PDT	Active low input for enabling output 3. 0 = Enable output, 1 = Disable output.
34	OEb2_SBI_OUT	I, SE, PD	Active low input for enabling output 2 or the SBI shift register data output. The function is this pin is controlled by the SBI_ENQ pin. For more information, see <a href="#">Side-Band Interface (SBI)</a> . <b>Note: This pin is NOT PDT.</b> OE mode: 0 = Enable output, 1 = Disable output. Side-Band mode: SBI shift register data output.
35	CLK2	O, DIF	True clock output.
36	CLKb2	O, DIF	Complementary clock output.
37	VDDCLK	PWR	Clock power supply.
38	CLK1	O, DIF	True clock output.
39	CLKb1	O, DIF	Complementary clock output.
40	OEb1	I, SE, PD, PDT	Active low input for enabling output 1. 0 = Enable output, 1 = Disable output.
41	EPAD	GND	Connect epad to ground.

## 1.8 RC19004A Pin Assignments

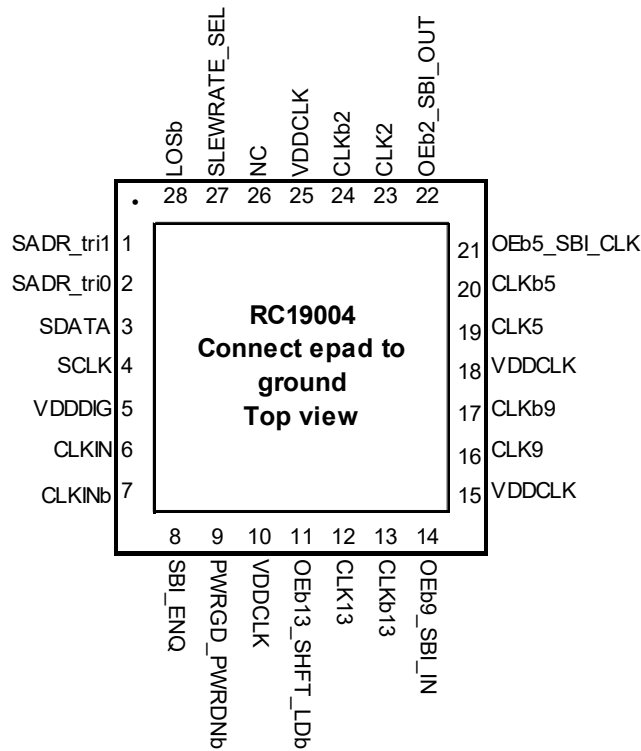

Figure 8. RC19004A 28-VFQFPN – Top View

### 1.8.1 RC19004A Pin Descriptions

Table 7. RC19004A Pin Descriptions

Pin Number	Pin Name	Type	Description
1	SADR_tri1	I, SE, PD, PU	SMBus address bit. This is a tri-level input that works in conjunction with other SADR pins, if present, to decode SMBus Addresses. See the <a href="#">SMBus Address Decode</a> table and the tri-level input thresholds in the electrical tables.
2	SADR_tri0	I, SE, PD, PU	SMBus address bit. This is a tri-level input that works in conjunction with other SADR pins, if present, to decode SMBus Addresses. See the <a href="#">SMBus Address Decode</a> table and the tri-level input thresholds in the electrical tables.
3	SDATA	I/O, SE, OD	Data pin for SMBus interface.
4	SCLK	I, SE	Clock pin of SMBus interface.
5	VDDDIG	PWR	Digital power.
6	CLKIN	I, DIF	True clock input.
7	CLKINb	I, DIF	Complementary clock input.
8	SBI_ENQ	I, SE, PD, PDT	Input that selects function of pins that are multiplexed between OE and SBI functionality. SMBus output enable bits and non-multiplexed OE pins remain functional when SBI is enabled. This pin must be strapped to its desired state. It cannot dynamically change. 0 = SBI is disabled. Multiplexed pins function as output enables. 1 = SBI is enabled. Multiplexed pins function as SBI control pins.
9	PWRGD_PWRDNb	I, SE, PU, PDT	Input notifies device to sample latched inputs and start up on first high assertion. Low enters Power Down Mode, subsequent high assertions exit Power Down Mode.

Table 7. RC19004A Pin Descriptions (Cont.)

Pin Number	Pin Name	Type	Description
10	VDDCLK	PWR	Clock power supply.
11	OEb13_SHFT_LDb	I, SE, PD, PDT	Active low input for enabling output 13 or SHFT_LDb pin for the Side-Band Interface. The function of this pin is controlled by the SBI_ENQ pin. For more information, see <a href="#">Side-Band Interface (SBI)</a> . OE mode: 0 = Enable output, 1 = Disable output. Side-Band mode: 0 = Disable SBI shift register, 1 = Enable SBI shift register. A falling edge transfers SBI shift register contents to SBI output control register.
12	CLK13	O, DIF	True clock output.
13	CLKb13	O, DIF	Complementary clock output.
14	OEb9_SBI_IN	I, SE, PD, PDT	Active low input for enabling output 9 or the data pin for the Side-Band Interface. The function of this pin is controlled by the SBI_ENQ pin. For more information, see <a href="#">Side-Band Interface (SBI)</a> . OE mode: 0 = Enable output, 1 = Disable output. Side-Band mode: SBI shift register data input pin
15	VDDCLK	PWR	Clock power supply.
16	CLK9	O, DIF	True clock output.
17	CLKb9	O, DIF	Complementary clock output.
18	VDDCLK	PWR	Clock power supply.
19	CLK5	O, DIF	True clock output.
20	CLKb5	O, DIF	Complementary clock output.
21	OEb5_SBI_CLK	I, SE, PD, PDT	Active low input for enabling output 5 or the clock pin for the SBI shift register. The function of this pin is controlled by the SBI_ENQ pin. For more information, see <a href="#">Side-Band Interface (SBI)</a> . OE mode: 0 = Enable output, 1 = Disable output. Side-Band mode: Clocks data into the SBI on the rising edge.
22	OEb2_SBI_OUT	I, SE, PD	Active low input for enabling output 2 or the SBI shift register data output. The function of this pin is controlled by the SBI_ENQ pin. For more information, see <a href="#">Side-Band Interface (SBI)</a> . <b>Note: This pin is NOT PDT.</b> OE mode: 0 = Enable output, 1 = Disable output. Side-Band mode: SBI shift register data output.
23	CLK2	O, DIF	True clock output.
24	CLKb2	O, DIF	Complementary clock output.
25	VDDCLK	PWR	Clock power supply.
26	NC	NC	No connect.
27	SLEWRATE_SEL	I, SE, PU, PDT	Input to select default slew rate of the outputs. 0 = Slow Slew Rate, 1 = Fast Slew Rate.

Table 7. RC19004A Pin Descriptions (Cont.)

Pin Number	Pin Name	Type	Description
28	LOSb	O, OD, PDT	Output indicating Loss of Input Signal. This pin is an open drain output and requires an external pull up resistor for proper functionality. A low output on this pin indicates a loss of signal on the input clock.
29	EPAD	GND	Connect to ground.

## 2. Specifications

### 2.1 Absolute Maximum Ratings

Symbol	Parameter	Condition	Minimum	Maximum	Unit
$V_{DDx}$	Supply Voltage with respect to Ground	Any VDD pin	-0.5	3.9	V
$V_{IN}$	Input Voltage	[1]	-0.5	3.9	V
$V_{IN}$	Input Voltage	[2]	-0.5	$V_{DDx} + 0.3$	V
$I_{IN}$	Input Current	All SE inputs and CLKIN [2]	-	$\pm 50$	mA
$I_{OUT}$	Output Current – Continuous	CLK	-	30	mA
		SDATA, SBI_OUT	-	25	mA
	Output Current – Surge	CLK	-	60	mA
		SDATA, SBI_OUT	-	50	mA
$T_J$	Maximum Junction Temperature	-	-	150	°C
$T_S$	Storage Temperature	Storage Temperature	-65	150	°C

1. Pins designated Power Down Tolerant (PDT) in the pin description tables.
2. Pins not designated Power Down Tolerant (PDT) in the pin description tables.

### 2.2 ESD Ratings

Symbol	Parameter	Condition	Rating	Unit
ESD	Human Body Model	JESD22-A114 (JS-001) Classification	2000	V
	Charged Device Model	JESD22-C101 Classification	500	V

## 2.3 Recommended Operation Conditions

Symbol	Parameter	Condition	Minimum	Typical	Maximum	Unit
$T_J$	Maximum Junction Temperature	-	-	-	125	°C
$T_A$	Ambient Operating Temperature	-	-40	25	105	°C
$V_{DDx}$	Supply Voltage with respect to Ground	Any VDD pin, 3.3V $\pm$ 10% supply.	2.97	3.3	3.63	V
$t_{PU}$	Power-up time for all VDDs to reach minimum specified voltage (power ramps must be monotonic)	Power-up time for all VDDs to reach minimum specified voltage (power ramps must be monotonic).	0.05	-	5	ms

## 2.4 Thermal Information

Package [1]	Symbol	Condition	Typical Value (°C/W)
8 × 8 mm 100-VFQFPN (5.1 × 5.1 mm ePad)	$\theta_{Jc}$	Junction to Case	8.6
	$\theta_{Jb}$	Junction to Base	0.6
	$\theta_{JA0}$	Junction to Air, still air	21.4
	$\theta_{JA1}$	Junction to Air, 1 m/s air flow	17.9
	$\theta_{JA3}$	Junction to Air, 3 m/s air flow	15.8
	$\theta_{JA5}$	Junction to Air, 5 m/s air flow	15.3
6 × 6 mm 80-GQFN (2.8 × 2.8 mm ePad)	$\theta_{Jc}$	Junction to Case	44
	$\theta_{Jb}$	Junction to Base	2
	$\theta_{JA0}$	Junction to Air, still air	33
	$\theta_{JA1}$	Junction to Air, 1 m/s air flow	29
	$\theta_{JA3}$	Junction to Air, 3 m/s air flow	28
	$\theta_{JA5}$	Junction to Air, 5 m/s air flow	27
10 × 10 mm 72-VFQFPN (5.95 × 5.95 mm ePad)	$\theta_{Jc}$	Junction to Case	16.9
	$\theta_{Jb}$	Junction to Base	2.7
	$\theta_{JA0}$	Junction to Air, still air	26.4
	$\theta_{JA1}$	Junction to Air, 1 m/s air flow	22.7
	$\theta_{JA3}$	Junction to Air, 3 m/s air flow	20.6
	$\theta_{JA5}$	Junction to Air, 5 m/s air flow	19.8
9 × 9 mm 64-VFQFPN (5.2 × 5.2 mm ePad)	$\theta_{Jc}$	Junction to Case	24.6
	$\theta_{Jb}$	Junction to Base	2.7
	$\theta_{JA0}$	Junction to Air, still air	26.8
	$\theta_{JA1}$	Junction to Air, 1 m/s air flow	22.9
	$\theta_{JA3}$	Junction to Air, 3 m/s air flow	21.5
	$\theta_{JA5}$	Junction to Air, 5 m/s air flow	20.7

Package [1]	Symbol	Condition	Typical Value (°C/W)
7 × 7 mm 56-VFQFPN (5.3 × 5.3 mm ePad)	$\theta_{Jc}$	Junction to Case	26.6
	$\theta_{Jb}$	Junction to Base	3.4
	$\theta_{JA0}$	Junction to Air, still air	26.9
	$\theta_{JA1}$	Junction to Air, 1 m/s air flow	23.4
	$\theta_{JA3}$	Junction to Air, 3 m/s air flow	21.9
	$\theta_{JA5}$	Junction to Air, 5 m/s air flow	21.0
5 × 5 mm 40-VFQFPN (3.3 × 3.3 mm ePad)	$\theta_{Jc}$	Junction to Case	37.0
	$\theta_{Jb}$	Junction to Base	4.8
	$\theta_{JA0}$	Junction to Air, still air	33.1
	$\theta_{JA1}$	Junction to Air, 1 m/s air flow	29.6
	$\theta_{JA3}$	Junction to Air, 3 m/s air flow	28.0
	$\theta_{JA5}$	Junction to Air, 5 m/s air flow	27.1
4 × 4 mm 28-VFQFPN (2.6 × 2.6 mm ePad)	$\theta_{Jc}$	Junction to Case	45.3
	$\theta_{Jb}$	Junction to Base	2.2
	$\theta_{JA0}$	Junction to Air, still air	36.3
	$\theta_{JA1}$	Junction to Air, 1 m/s air flow	32.7
	$\theta_{JA3}$	Junction to Air, 3 m/s air flow	31.0
	$\theta_{JA5}$	Junction to Air, 5 m/s air flow	30.0

1. ePad soldered to board.



## 2.5 Electrical Characteristics

### 2.5.1 Phase Jitter

Table 8. PCIe Refclk Phase Jitter - Normal Conditions<sup>[1][2][3][8]</sup>

Symbol	Parameter	Condition	Typical	Maximum	Specification Limit	Unit
t <sub>jph</sub> PCIeG1-CC	Additive PCIe Phase Jitter (Common Clocked Architecture) SSC ≤ -0.5%	PCIe Gen1 (2.5 GT/s)	528	623	86,000 <sup>[6]</sup>	fs p-p
t <sub>jph</sub> PCIeG2-CC		PCIe Gen2 Hi Band (5.0 GT/s)	32	37	3,100 <sup>[6]</sup>	fs RMS
t <sub>jph</sub> PCIeG3-CC		PCIe Gen2 Lo Band (5.0 GT/s)	9	11	3,000 <sup>[6]</sup>	
t <sub>jph</sub> PCIeG4-CC		PCIe Gen3 (8.0 GT/s)	15	18	1,000 <sup>[6]</sup>	
t <sub>jph</sub> PCIeG5-CC		PCIe Gen4 (16.0 GT/s) <sup>[3] [4]</sup>	15	18	500 <sup>[6]</sup>	
t <sub>jph</sub> PCIeG6-CC		PCIe Gen5 (32.0 GT/s) <sup>[3] [5]</sup>	6	7	150 <sup>[6]</sup>	
t <sub>jph</sub> PCIeG6-CC		PCIe Gen6 (64.0 GT/s) <sup>[3] [5]</sup>	3.5	4.1	100 <sup>[6]</sup>	
t <sub>jph</sub> PCIeG2-IR	Additive PCIe Phase Jitter (IR Architectures - SRIS, SRNS) SSC ≤ -0.3%	PCIe Gen2 (5.0 GT/s)	41	48	[7]	fs RMS
t <sub>jph</sub> PCIeG3-IR		PCIe Gen3 (8.0 GT/s)	11	13		
t <sub>jph</sub> PCIeG4-IR		PCIe Gen4 (16.0 GT/s) <sup>[3] [4]</sup>	11	13		
t <sub>jph</sub> PCIeG5-IR		PCIe Gen5 (32.0 GT/s) <sup>[3] [5]</sup>	10	11		
t <sub>jph</sub> PCIeG6-IR		PCIe Gen6 (64.0 GT/s) <sup>[3] [5]</sup>	12	14		

1. The Refclk jitter is measured after applying the filter functions found in the *PCI Express Base Specification 6.0, Revision 1.0*. For the exact measurement setup, see [Test Loads](#). The worst case results for each data rate are summarized in this table. Equipment noise is removed from all measurements.
2. Jitter measurements should be made with a capture of at least 100,000 clock cycles captured by a real-time oscilloscope (RTO) with a sample rate of 20GS/s or greater. Broadband oscilloscope noise must be minimized in the measurement. The measured PP jitter is used (no extrapolation) for RTO measurements. Alternately, jitter measurements can be used with a Phase Noise Analyzer (PNA) extending (flat) and integrating and folding the frequency content up to an offset from the carrier frequency of at least 200MHz (at 300MHz absolute frequency) below the Nyquist frequency. For PNA measurements for the 2.5GT/s data rate, the RMS jitter is converted to peak-to-peak jitter using a multiplication factor of 8.83.
3. SSC spurs from the fundamental and harmonics are removed up to a cutoff frequency of 2MHz taking care to minimize removal of any non-SSC content.
4. Note that 0.7ps RMS is to be used in channel simulations to account for additional noise in a real system.
5. Note that 0.25ps RMS is to be used in channel simulations to account for additional noise in a real system.
6. The rms sum of the source jitter and the additive jitter (arithmetic sum for PCIe Gen1) must be less than the jitter specification listed.
7. The *PCI Express Base Specification 6.0, Revision 1.0* provides the filters necessary to calculate SRIS jitter values; it does not provide specification limits, therefore, the reference to this footnote in the Limit column. SRIS values are informative only. A common practice is to split the common clock budget in half. For 16GT/s data rates and above, the user must choose whether to use the output jitter specification, or the input jitter specification, which includes an allocation for the jitter added by the channel. Using 32GT/s, the Refclk jitter budget is 150fs RMS. One half of the Refclk jitter budget is 106fs RMS. At the clock input, the system must deliver 250fs RMS. One half of this value is 177fs RMS. If the clock is placed next to the PCIe device in an SRIS system, the channel is very short and the user can choose to use this more relaxed value as the jitter limit.
8. Differential input swing ≥ 1600mV and input slew rate ≥ 3.5V/ns

Table 9. PCIe Refclk Phase Jitter - Degraded Conditions<sup>[1][2][3][8]</sup>

Symbol	Parameter	Condition	Typical	Maximum	Specification Limit	Unit
$t_{jphPCIeG1-CC}$	Additive PCIe Phase Jitter (Common Clocked Architecture) SSC $\leq -0.5\%$	PCIe Gen1 (2.5 GT/s)	692	839	86,000 <sup>[6]</sup>	fs p-p
$t_{jphPCIeG2-CC}$		PCIe Gen2 Hi Band (5.0 GT/s)	41	49	3,100 <sup>[6]</sup>	fs RMS
$t_{jphPCIeG3-CC}$		PCIe Gen2 Lo Band (5.0 GT/s)	11	14	3,000 <sup>[6]</sup>	
$t_{jphPCIeG4-CC}$		PCIe Gen3 (8.0 GT/s)	20	24	1,000 <sup>[6]</sup>	
$t_{jphPCIeG5-CC}$		PCIe Gen4 (16.0 GT/s) <sup>[3][4]</sup>	20	24	500 <sup>[6]</sup>	
$t_{jphPCIeG6-CC}$		PCIe Gen5 (32.0 GT/s) <sup>[3][5]</sup>	8	9.3	150 <sup>[6]</sup>	
$t_{jphPCIeG6-CC}$		PCIe Gen6 (64.0 GT/s) <sup>[3][5]</sup>	5	6	100 <sup>[6]</sup>	
$t_{jphPCIeG2-IR}$	Additive PCIe Phase Jitter (IR Architectures - SRIS, SRNS) SSC $\leq -0.3\%$	PCIe Gen2 (5.0 GT/s)	52	63	[7]	fs RMS
$t_{jphPCIeG3-IR}$		PCIe Gen3 (8.0 GT/s)	14	17		
$t_{jphPCIeG4-IR}$		PCIe Gen4 (16.0 GT/s) <sup>[3][4]</sup>	14	17		
$t_{jphPCIeG5-IR}$		PCIe Gen5 (32.0 GT/s) <sup>[3][5]</sup>	12	15		
$t_{jphPCIeG6-IR}$		PCIe Gen6 (64.0 GT/s) <sup>[3][5]</sup>	15	19		

1. The Refclk jitter is measured after applying the filter functions found in the *PCI Express Base Specification 6.0, Revision 1.0*. For the exact measurement setup, see [Test Loads](#). The worst case results for each data rate are summarized in this table. Equipment noise is removed from all measurements.
2. Jitter measurements should be made with a capture of at least 100,000 clock cycles captured by a real-time oscilloscope (RTO) with a sample rate of 20GS/s or greater. Broadband oscilloscope noise must be minimized in the measurement. The measured PP jitter is used (no extrapolation) for RTO measurements. Alternately, jitter measurements may be used with a Phase Noise Analyzer (PNA) extending (flat) and integrating and folding the frequency content up to an offset from the carrier frequency of at least 200MHz (at 300MHz absolute frequency) below the Nyquist frequency. For PNA measurements for the 2.5GT/s data rate, the RMS jitter is converted to peak-to-peak jitter using a multiplication factor of 8.83.
3. SSC spurs from the fundamental and harmonics are removed up to a cutoff frequency of 2MHz taking care to minimize removal of any non-SSC content.
4. Note that 0.7ps RMS is to be used in channel simulations to account for additional noise in a real system.
5. Note that 0.25ps RMS is to be used in channel simulations to account for additional noise in a real system.
6. The rms sum of the source jitter and the additive jitter (arithmetic sum for PCIe Gen1) must be less than the jitter specification listed.
7. The *PCI Express Base Specification 6.0, Revision 1.0* provides the filters necessary to calculate SRIS jitter values; it does not provide specification limits, therefore, the reference to this footnote in the Limit column. SRIS values are informative only. A common practice is to split the common clock budget in half. For 16GT/s data rates and above, the user must choose whether to use the output jitter specification, or the input jitter specification, which includes an allocation for the jitter added by the channel. Using 32GT/s, the Refclk jitter budget is 150fs RMS. One half of the Refclk jitter budget is 106fs RMS. At the clock input, the system must deliver 250fs RMS. One half of this value is 177fs RMS. If the clock is placed next to the PCIe device in an SRIS system, the channel is very short and the user may choose to use this more relaxed value as the jitter limit.
8. Differential input swing = 800mV and input slew rate = 1.5V/ns

**Table 10. Non-PCIe Refclk Phase Jitter [1][2][3]**

Symbol	Parameter	Condition	Typical	Maximum	Specification Limit	Unit
$t_{jphDB2000Q}$	Additive Phase Jitter - normal conditions <sup>[4]</sup>	100MHz, Intel-supplied filter <sup>[3]</sup>	10	12	80 <sup>[5]</sup>	fs RMS
$t_{jph12k-20M}$		156.25MHz (12kHz to 20MHz)	30	36	N/A	
$t_{jphDB2000Q}$	Additive Phase Jitter - degraded conditions <sup>[6]</sup>	100MHz, Intel-supplied filter <sup>[3]</sup>	13	16	80 <sup>[5]</sup>	
$t_{jph12k-20M}$		156.25MHz (12kHz to 20MHz)	39	48	N/A	

1. See [Test Loads](#) for test configuration.
2. SMA100B used as signal source.
3. The RC19xxx devices meet all legacy QPI/UPI specifications by meeting the PCIe and DB2000Q specifications listed in this document.
4. Differential input swing = 1,600mV and input slew rate = 3.5V/ns.
5. The rms sum of the source jitter and the additive jitter (arithmetic sum for PCIe Gen1) must be less than the jitter specification listed.
6. Differential input swing = 800mV and input slew rate = 1.5V/ns.

## 2.5.2 Output Frequencies, Startup Time, and LOS Timing

**Table 11. Output Frequencies, Startup Time, and LOS Timing**

Symbol	Parameter	Condition	Minimum	Typical	Maximum	Unit
$f_{OP}$	Operating Frequency	Automatic Clock Parking (ACP) Circuit disabled	1	-	400	MHz
		Automatic Clock Parking (ACP) Circuit enabled	25	-	400	
$t_{STARTUP}$	Start-up Time	<sup>[1]</sup>	-	1.2	3	ms
$t_{STARTUP}$	Start-up Time	<sup>[2]</sup>	-	0.3	1	ms
$t_{LATOEB}$	OEB latency	OEB assertion/de-assertion CLK start/stop latency. Input clock must be running.	4	5	10	clks
$t_{LOSAssert}$	LOS Assert Time	Time from disappearance of input clock to LOS assert. <sup>[3][4]</sup>	-	123	200	ns
$t_{LOSDeassert}$	LOS Deassert Time	Time from appearance of input clock to LOS deassert. <sup>[3][5]</sup>	-	6	9	clks

1. Measured from when all power supplies have reached > 90% of nominal voltage to the first stable clock edge on the output. PWRGD\_PWRDNb tied to VDD in this case.
2. VDD stable, measured from de-assertion of PWRGD\_PWRDNb.
3. The clock detect circuit does not qualify the accuracy of the input clock. The first input clock must appear to release the power on reset and enable the LOS circuit at power up.
4. PWRGD\_PWRDNb high. The Automatic Clock Parking (ACP) circuit - if enabled - will park the outputs in a low/low state within this time. See Byte4, bit 4 LOSb\_ACP\_ENABLE.
5. PWRGD\_PWRDNb high. The device will drive the outputs to a high/low state within this time and then begin clocking the outputs.

### 2.5.3 RC1902xA CLK AC/DC Output Characteristics

The tables in this section apply to the RC19024A, RC19020A and RC19020A072.

**Table 12. RC1902xA 85-ohm CLK AC/DC Characteristics - Source-Terminated 100MHz PCIe [1]**

Symbol	Parameter	Conditions	Minimum	Typical	Maximum	Specification Limit [2]	Unit
$V_{MAX}$	Absolute Max Voltage Includes 300mV of Overshoot (Vovs) [3][4]	Across all settings in this table at 100MHz.	-	-	1092	1150	mV
$V_{MIN}$	Absolute Min Voltage Includes -300mV of Undershoot (Vuds) [3][5]		-166	-	-	-300	
$V_{HIGH}$	Voltage High [3]	$V_{HIGH}$ set to 800mV.	678	819	994	-	
$V_{LOW}$	Voltage Low [3]		-88	29	146	-	
$V_{CROSS}$	Crossing Voltage (abs) [3][6][7]	$V_{HIGH}$ set to 800mV, scope averaging off.	278	403	543	250 to 550	
$\Delta V_{CROSS}$	Crossing Voltage (var) [3][6][8]		-	1	97	140	
dv/dt	Slew Rate [9][10]	$V_{HIGH}$ set to 800mV, Fast slew rate, scope averaging on.	2.0	2.8	4.0	2 to 5	V/ns
		$V_{HIGH}$ set to 800mV, Slow slew rate, scope averaging on.	1.6	2.2	3.3	1.5 to 3.5	
$\Delta T_{R/F}$	Rise/Fall Matching [3][11]	$V_{HIGH}$ set to 800mV. Fast slew rate.	-	4	19	20	%
		$V_{HIGH}$ set to 800mV. Slow slew rate.	-	6	24	N/A	
$V_{HIGH}$	Voltage High [3]	$V_{HIGH}$ set to 900mV.	719	903	1090	-	mV
$V_{LOW}$	Voltage Low [3]		-115	37	163	-	
$V_{CROSS}$	Crossing Voltage (abs) [3][6][7]	$V_{HIGH}$ set to 900mV, scope averaging off.	289	445	582	250 to 600	
$\Delta V_{CROSS}$	Crossing Voltage (var) [3][6][8]		-	1	105	140	
dv/dt	Slew Rate [9][10]	$V_{HIGH}$ set to 900mV, Fast slew rate, scope averaging on.	2.1	2.9	4.3	2 to 5	V/ns
		$V_{HIGH}$ set to 900mV, Slow slew rate, scope averaging on.	1.7	2.3	3.5	1.5 to 3.5	
$\Delta T_{R/F}$	Rise/Fall Matching [3][11]	$V_{HIGH}$ set to 900mV. Fast slew rate.	-	5	18	20	%
		$V_{HIGH}$ set to 900mV. Slow slew rate.	-	6	26	N/A	
$t_{DC}$	Output Duty Cycle [9]	$V_T = 0V$ differential. 50% duty cycle input.	49	49.9	51	45 to 55	%

- Standard high impedance load with  $C_L = 2pF$ . See [Test Loads](#).
- The specification limits are taken from either the *PCIe Base Specification Revision 6.0* or from relevant x86 processor specifications, whichever is more stringent.
- Measured from single-ended waveform.
- Defined as the maximum instantaneous voltage including overshoot.
- Defined as the minimum instantaneous voltage including undershoot.

6. Measured at crossing point where the instantaneous voltage value of the rising edge of REFCLK+ equals the falling edge of REFCLK-.
7. Refers to the total variation from the lowest crossing point to the highest, regardless of which edge is crossing. Refers to all crossing points for this measurement.
8. Defined as the total variation of all crossing voltages of Rising REFCLK+ and Falling REFCLK-. This is the maximum allowed variance in VCROSS for any particular system.
9. Measured from differential waveform.
10. Measured from -150 mV to +150 mV on the differential waveform (derived from REFCLK+ minus REFCLK-). The signal must be monotonic through the measurement region for rise and fall time. The 300 mV measurement window is centered on the differential zero crossing.
11. Matching applies to rising edge rate for REFCLK+ and falling edge rate for REFCLK-. It is measured using a ±75 mV window centered on the median cross point where REFCLK+ rising meets REFCLK- falling. The median cross point is used to calculate the voltage thresholds the oscilloscope is to use for the edge rate calculations. The Rise Edge Rate of REFCLK+ should be compared to the Fall Edge Rate of REFCLK-; the maximum allowed difference should not exceed 20% of the slowest edge rate.

**Table 13. RC1902xA 85Ω CLK AC/DC Characteristics - Non-PCIe, Source-Terminated Loads [1]**

Symbol	Parameter	Conditions	Minimum	Typical	Maximum	Unit
V <sub>OH</sub>	Output High Voltage [2]	V <sub>HIGH</sub> = 800mV, Fast Slew Rate, 25MHz, 156.25MHz, 312.5MHz.	651	820	1003	mV
V <sub>OL</sub>	Output Low Voltage [2]		-142	18	169	
V <sub>CROSS</sub>	Crossing Voltage (abs) [3]		234	400	577	
ΔV <sub>CROSS</sub>	Crossing Voltage (var) [3][4][5]		-	56	148	
t <sub>R</sub>	Rise Time [2] V <sub>T</sub> = 20% to 80% of swing		142	442	753	ps
t <sub>F</sub>	Fall Time [2] V <sub>T</sub> = 20% to 80% of swing	173	435	756	ps	
V <sub>OH</sub>	Output High Voltage [2]	V <sub>HIGH</sub> = 900mV, Fast Slew Rate, 25MHz, 156.25MHz, 312.5MHz.	720	916	1130	mV
V <sub>OL</sub>	Output Low Voltage [2]		-164	25	190	
V <sub>CROSS</sub>	Crossing Voltage (abs) [3]		266	440	636	
ΔV <sub>CROSS</sub>	Crossing Voltage (var) [3][4][5]		-	35	162	
t <sub>R</sub>	Rise Time [2] V <sub>T</sub> = 20% to 80% of swing		164	502	861	ps
t <sub>F</sub>	Fall Time [2] V <sub>T</sub> = 20% to 80% of swing		160	432	757	ps
t <sub>DC</sub>	Output Duty Cycle [6]	Across all settings in this table, V <sub>T</sub> = 0V.	47	49.7	52	%

1. Standard high impedance load with C<sub>L</sub> = 2pF. See [Test Loads](#).
2. Measured from single-ended waveform.
3. Measured at crossing point where the instantaneous voltage value of the rising edge of CLK equals the falling edge of CLKb.
4. Refers to the total variation from the lowest crossing point to the highest, regardless of which edge is crossing. Refers to all crossing points for this measurement.
5. Defined as the total variation of all crossing voltages of Rising CLK and Falling CLKb. This is the maximum allowed variance in VCROSS for any particular system.
6. Measured from differential waveform.

Table 14. RC1902xA 85Ω CLK AC/DC Characteristics - Non-PCIe, Double-Terminated Loads [1]

Symbol	Parameter	Conditions	Minimum	Typical	Maximum	Unit	
V <sub>OH</sub>	Output High Voltage [2]	V <sub>HIGH</sub> = 800mV, Fast Slew Rate, 25MHz, 156.25MHz, 312.5MHz (amplitude is reduced by ~50% due to double termination).	372	430	473	mV	
V <sub>OL</sub>	Output Low Voltage [2]		-32	11	57		
V <sub>CROSS</sub>	Crossing Voltage (abs) [3]		156	205	243		
ΔV <sub>CROSS</sub>	Crossing Voltage (var) [3][4][5]			-	8	38	
t <sub>R</sub>	Rise Time [2] V <sub>T</sub> = 20% to 80% of swing			211	400	561	ps
t <sub>F</sub>	Fall Time [2] V <sub>T</sub> = 20% to 80% of swing			130	263	381	ps
V <sub>OH</sub>	Output High Voltage [2]	V <sub>HIGH</sub> = 900mV, Fast Slew Rate, 25MHz, 100MHz, 156.25MHz, 312.5MHz (amplitude is reduced by ~50% due to double termination).	389	479	549	mV	
V <sub>OL</sub>	Output Low Voltage [2]		-31	12	55		
V <sub>CROSS</sub>	Crossing Voltage (abs) [3]		173	222	265		
ΔV <sub>CROSS</sub>	Crossing Voltage (var) [3][4][5]			-	8	41	
t <sub>R</sub>	Rise Time [2] V <sub>T</sub> = 20% to 80% of swing			220	477	635	ps
t <sub>F</sub>	Fall Time [2] V <sub>T</sub> = 20% to 80% of swing			152	268	356	ps
t <sub>DC</sub>	Output Duty Cycle [6]	Across all settings in this table, V <sub>T</sub> = 0V.	49	49.8	51	%	

- Both Tx and Rx are terminated (double-terminated) with C<sub>L</sub> = 2pF. This reduces amplitude by 50%. See [Test Loads](#).
- Measured from single-ended waveform.
- Measured at crossing point where the instantaneous voltage value of the rising edge of CLK equals the falling edge of CLKb.
- Refers to the total variation from the lowest crossing point to the highest, regardless of which edge is crossing. Refers to all crossing points for this measurement.
- Defined as the total variation of all crossing voltages of Rising CLK and Falling CLKb. This is the maximum allowed variance in VCROSS for any particular system.
- Measured from differential waveform.

## 2.5.4 RC1901xA/RC1900xA CLK AC/DC Output Characteristics

The tables in the section apply to the RC19016A/A100, RC19013A/A100, RC19008A/A100, and RC19004A/A100.

**Table 15. RC1901xA/RC1900xA 85Ω CLK AC/DC Characteristics - Source-Terminated 100MHz PCIe Applications [1]**

Symbol	Parameter	Condition	Minimum	Typical	Maximum	Specification Limit [2]	Unit
$V_{MAX}$	Absolute Max Voltage Includes 300mV of Overshoot (Vovs) [3][4]	Across all settings in this table at 100MHz.	-	871	968	1150	mV
$V_{MIN}$	Absolute Min Voltage Includes -300mV of Undershoot (Vuds) [3][5]		-45	2	36	-300	
$V_{HIGH}$	Voltage High [3]	$V_{HIGH}$ set to 800mV.	713	795	869	-	mV
$V_{LOW}$	Voltage Low [3]		-43	31	108	-	
$V_{CROSS}$	Crossing Voltage (abs) [3] [6][7]	$V_{HIGH}$ set to 800mV, scope averaging off.	286	406	519	250 to 550	
$\Delta V_{CROSS}$	Crossing Voltage (var) [3] [6][8]		-	31	136	140	
dv/dt	Slew Rate [9][10]	$V_{HIGH}$ set to 800mV, Fast slew rate, scope averaging on.	2.1	3.2	4.6	2 to 5	V/ns
		$V_{HIGH}$ set to 800mV, Slow slew rate, scope averaging on.	1.6	2.3	3.2	1.5 to 3.5	
$\Delta T_{R/F}$	Rise/Fall Matching [3][11]	$V_{HIGH}$ set to 800mV. Fast slew rate.	-	5%	15%	20	%
$\Delta T_{R/F}$	Rise/Fall Matching [3][11]	$V_{HIGH}$ set to 800mV. Slow slew rate.	-	7%	15%	20	%
$V_{HIGH}$	Voltage High [3]	$V_{HIGH}$ set to 900mV.	793	883	964	-	mV
$V_{LOW}$	Voltage Low [3]		-44	32	112	-	
$V_{CROSS}$	Crossing Voltage (abs) [3] [6][7]	$V_{HIGH}$ set to 900mV, scope averaging off.	312	441	567	300 to 600	
$\Delta V_{CROSS}$	Crossing Voltage (var) [3] [6][8]		-	33	140	140	
dv/dt	Slew Rate [9][10]	$V_{HIGH}$ set to 900mV, Fast slew rate, scope averaging on.	2.1	3.4	4.9	2 to 5	V/ns
		$V_{HIGH}$ set to 900mV, Slow slew rate, scope averaging on.	1.6	2.4	3.3	1.5 to 3.5	
$\Delta T_{R/F}$	Rise/Fall Matching [3][11]	$V_{HIGH}$ set to 900mV. Fast slew rate.	-	5%	15%	20	%
$\Delta T_{R/F}$	Rise/Fall Matching [3][11]	$V_{HIGH}$ set to 900mV. Slow slew rate.	-	7%	17%	20	%
$t_{DC}$	Output Duty Cycle [9]	$V_T = 0V$ differential.	48.9	49.8	50.7	45 to 55	%

1. Standard high impedance load with  $C_L = 2pF$ . For more information, see [Test Loads](#).
2. The specification limits are taken from either the *PCIe Base Specification Revision 6.0* or from relevant x86 processor specifications, whichever is more stringent.
3. Measured from single-ended waveform.
4. Defined as the maximum instantaneous voltage including overshoot.

5. Defined as the minimum instantaneous voltage including undershoot.
6. Measured at crossing point where the instantaneous voltage value of the rising edge of REFCLK+ equals the falling edge of REFCLK-.
7. Refers to the total variation from the lowest crossing point to the highest, regardless of which edge is crossing. Refers to all crossing points for this measurement.
8. Defined as the total variation of all crossing voltages of Rising REFCLK+ and Falling REFCLK-. This is the maximum allowed variance in VCROSS for any particular system.
9. Measured from differential waveform.
10. Measured from -150mV to +150mV on the differential waveform (derived from REFCLK+ minus REFCLK-). The signal must be monotonic through the measurement region for rise and fall time. The 300mV measurement window is centered on the differential zero crossing.
11. Matching applies to rising edge rate for REFCLK+ and falling edge rate for REFCLK-. It is measured using a ±75mV window centered on the median cross point where REFCLK+ rising meets REFCLK- falling. The median cross point is used to calculate the voltage thresholds the oscilloscope is to use for the edge rate calculations. The Rise Edge Rate of REFCLK+ should be compared to the Fall Edge Rate of REFCLK-; the maximum allowed difference should not exceed 20% of the slowest edge rate.

**Table 16. RC1901xA\RC1900xA 100Ω CLK AC/DC Characteristics - Source-Terminated 100MHz PCIe Apps [1]**

Symbol	Parameter	Condition	Minimum	Typical	Maximum	Specification Limit [2]	Unit
$V_{MAX}$	Absolute Max Voltage Includes 300mV of Overshoot (Vovs) [3][4]	Across all settings in this table at 100MHz.	844	930	1017	1150	mV
$V_{MIN}$	Absolute Min Voltage Includes -300mV of Undershoot (Vuds) [3][5]		-51	7	65	-300	
$V_{HIGH}$	Voltage High [3]	$V_{HIGH}$ set to 800mV.	713	816	918	-	mV
$V_{LOW}$	Voltage Low [3]		-35	22	78	-	
$V_{CROSS}$	Crossing Voltage (abs) [3] [6][7]	$V_{HIGH}$ set to 800mV, scope averaging off.	296	420	498	250 to 550	mV
$\Delta V_{CROSS}$	Crossing Voltage (var) [3] [6][8]		-28	39	106	140	
dv/dt	Slew Rate [9][10]	$V_{HIGH}$ set to 800mV, Fast slew rate, scope averaging on.	2.1	2.9	3.7	2 to 4	V/ns
		$V_{HIGH}$ set to 800mV, Slow slew rate, scope averaging on.	1.6	2.4	3.2	1.5 to 3.5	
$\Delta T_{R/F}$	Rise/Fall Matching [3][11]	$V_{HIGH}$ set to 800mV. Fast slew rate.	-	3.6	15.6	20	%
$\Delta T_{R/F}$	Rise/Fall Matching [3][11]	$V_{HIGH}$ set to 800mV. Slow slew rate.	-	3.5	15.5	20	%
$V_{HIGH}$	Voltage High [3]	$V_{HIGH}$ set to 900mV.	802	907	1012	-	mV
$V_{LOW}$	Voltage Low [3]		-38	21	80	-	
$V_{CROSS}$	Crossing Voltage (abs) [3] [6][7]	$V_{HIGH}$ set to 900mV, scope averaging off.	326	454	535	300 to 600	mV
$\Delta V_{CROSS}$	Crossing Voltage (var) [3] [6][8]		-31	40	111	140	
dv/dt	Slew Rate [9][10]	$V_{HIGH}$ set to 900mV, Fast slew rate, scope averaging on.	2.1	3.0	4.0	2 to 4	V/ns
		$V_{HIGH}$ set to 900mV, Slow slew rate, scope averaging on.	1.7	2.6	3.4	1.5 to 3.5	
$\Delta T_{R/F}$	Rise/Fall Matching [3][11]	$V_{HIGH}$ set to 900mV. Fast slew rate.	-	4.8	19.7	20	%



Table 16. RC1901xA\RC1900xA 100Ω CLK AC/DC Characteristics - Source-Terminated 100MHz PCIe Apps <sup>[1]</sup> (Cont.)

Symbol	Parameter	Condition	Minimum	Typical	Maximum	Specification Limit <sup>[2]</sup>	Unit
$\Delta T_{R/F}$	Rise/Fall Matching <sup>[3][11]</sup>	$V_{HIGH}$ set to 900mV. Slow slew rate.	-	4.9	19.4	20	%
$t_{DC}$	Output Duty Cycle <sup>[9]</sup>	$V_T = 0V$ differential.	49.6	49.9	50.2	45 to 55	%

1. Standard high impedance load with  $C_L = 2pF$ . For more information, see [Test Loads](#).
2. The specification limits are taken from either the *PCIe Base Specification Revision 6.0* or from relevant x86 processor specifications, whichever is more stringent.
3. Measured from single-ended waveform.
4. Defined as the maximum instantaneous voltage including overshoot.
5. Defined as the minimum instantaneous voltage including undershoot.
6. Measured at crossing point where the instantaneous voltage value of the rising edge of REFCLK+ equals the falling edge of REFCLK-.
7. Refers to the total variation from the lowest crossing point to the highest, regardless of which edge is crossing. Refers to all crossing points for this measurement.
8. Defined as the total variation of all crossing voltages of Rising REFCLK+ and Falling REFCLK-. This is the maximum allowed variance in VCROSS for any particular system.
9. Measured from differential waveform.
10. Measured from -150mV to +150mV on the differential waveform (derived from REFCLK+ minus REFCLK-). The signal must be monotonic through the measurement region for rise and fall time. The 300mV measurement window is centered on the differential zero crossing.
11. Matching applies to rising edge rate for REFCLK+ and falling edge rate for REFCLK-. It is measured using a  $\pm 75mV$  window centered on the median cross point where REFCLK+ rising meets REFCLK- falling. The median cross point is used to calculate the voltage thresholds the oscilloscope is to use for the edge rate calculations. The Rise Edge Rate of REFCLK+ should be compared to the Fall Edge Rate of REFCLK-; the maximum allowed difference should not exceed 20% of the slowest edge rate.

Table 17. RC1901xA/RC1900xA 85Ω CLK AC/DC Characteristics - Non-PCIe Apps, Source-Terminated Loads [1]

Symbol	Parameter	Condition	Minimum	Typical	Maximum	Unit
$V_{OH}$	Output High Voltage [2]	$V_{HIGH} = 800\text{mV}$ , Fast Slew Rate, 156.25MHz, 312.5MHz. (Slow slew rate is not recommended for frequencies > 100MHz)	695	811	950	mV
$V_{OL}$	Output Low Voltage [2]		-52	30	108	
$V_{CROSS}$	Crossing Voltage (abs) [3]		283	431	582	
$\Delta V_{CROSS}$	Crossing Voltage (var) [3][4][5]		0	35	168	
$t_R$	Rise Time [2] $V_T = 20\%$ to 80% of swing		93	334	543	ps
$t_F$	Fall Time [2] $V_T = 20\%$ to 80% of swing		103	293	539	ps
$V_{OH}$	Output High Voltage [2]	$V_{HIGH} = 900\text{mV}$ , Fast Slew Rate, 156.25MHz, 312.5MHz. (Slow slew rate is not recommended for frequencies > 100MHz)	744	901	1084	mV
$V_{OL}$	Output Low Voltage [2]		-51	27	102	
$V_{CROSS}$	Crossing Voltage (abs) [3]		234	446	656	
$\Delta V_{CROSS}$	Crossing Voltage (var) [3][4][5]		0	35	168	
$t_R$	Rise Time [2] $V_T = 20\%$ to 80% of swing		65	386	683	ps
$t_F$	Fall Time [2] $V_T = 20\%$ to 80% of swing		82	302	565	ps
$t_{DC}$	Output Duty Cycle [6]	Across all settings in this table, $V_T = 0V$ .	47.8	49.9	51.9	%

1. Standard high impedance load with  $C_L = 2\text{pF}$ . For more information, see [Test Loads](#).
2. Measured from single-ended waveform.
3. Measured at crossing point where the instantaneous voltage value of the rising edge of CLK equals the falling edge of CLKb.
4. Refers to the total variation from the lowest crossing point to the highest, regardless of which edge is crossing. Refers to all crossing points for this measurement.
5. Defined as the total variation of all crossing voltages of Rising CLK and Falling CLKb. This is the maximum allowed variance in  $V_{CROSS}$  for any particular system.
6. Measured from differential waveform.

**Table 18. RC1901xA/RC1900xA 85Ω CLK AC/DC Characteristics - Non-PCIe Apps, Double-Terminated Loads [1]**

Symbol	Parameter	Condition	Minimum	Typical	Maximum	Unit
V <sub>OH</sub>	Output High Voltage [2]	V <sub>HIGH</sub> = 800mV, Fast Slew Rate, 156.25MHz, 312.5MHz - amplitude is reduced by ~50% due to double termination. (Slow slew rate is not recommended for frequencies >100MHz)	385	431	475	mV
V <sub>OL</sub>	Output Low Voltage [2]		-22	12	46	
V <sub>CROSS</sub>	Crossing Voltage (abs) [3]		164	205	245	
ΔV <sub>CROSS</sub>	Crossing Voltage (var) [3][4][5]		-19	10	40	
t <sub>R</sub>	Rise Time [2] VT = 20% to 80% of swing		185	396	615	ps
t <sub>F</sub>	Fall Time [2] VT = 20% to 80% of swing		185	253	355	ps
V <sub>OH</sub>	Output High Voltage [2]	V <sub>HIGH</sub> = 900mV, Fast Slew Rate, 156.25MHz, 312.5MHz - amplitude is reduced by ~50% due to double termination. (Slow slew rate is not recommended for frequencies >100MHz)	430	479	526	mV
V <sub>OL</sub>	Output Low Voltage [2]		-22	12	46	
V <sub>CROSS</sub>	Crossing Voltage (abs) [3]		179	223	260	
ΔV <sub>CROSS</sub>	Crossing Voltage (var) [3][4][5]		-20	10	40	
t <sub>R</sub>	Rise Time [2] VT = 20% to 80% of swing		259	456	670	ps
t <sub>F</sub>	Fall Time [2] VT = 20% to 80% of swing		197	256	345	ps
t <sub>DC</sub>	Output Duty Cycle [6]	Across all settings in this table, V <sub>T</sub> = 0V.	48.6	49.8	50.7	%

- Both Tx and Rx are terminated (double-terminated) with C<sub>L</sub> = 2pF. This reduces amplitude by 50%. For more information, see [Test Loads](#).
- Measured from single-ended waveform.
- Measured at crossing point where the instantaneous voltage value of the rising edge of CLK equals the falling edge of CLKb.
- Refers to the total variation from the lowest crossing point to the highest, regardless of which edge is crossing. Refers to all crossing points for this measurement.
- Defined as the total variation of all crossing voltages of Rising CLK and Falling CLKb. This is the maximum allowed variance in VCROSS for any particular system.
- Measured from differential waveform.

**Table 19. RC1901xA/RC1900xA 100Ω CLK AC/DC Characteristics - Non-PCIe Apps, Source-Terminated Loads [1]**

Symbol	Parameter	Condition	Minimum	Typical	Maximum	Unit
V <sub>OH</sub>	Output High Voltage [2]	V <sub>HIGH</sub> = 800mV, Fast Slew Rate, 156.25MHz, 312.5MHz. (Slow slew rate is not recommended for frequencies > 100MHz)	702	808	914	mV
V <sub>OL</sub>	Output Low Voltage [2]		-73	34	118	
V <sub>CROSS</sub>	Crossing Voltage (abs) [3]		256	376	496	
ΔV <sub>CROSS</sub>	Crossing Voltage (var) [3][4][5]		0	37	133	
t <sub>R</sub>	Rise Time [2] VT = 20% to 80% of swing		217	376	467	ps
t <sub>F</sub>	Fall Time [2] VT = 20% to 80% of swing		140	365	576	ps
V <sub>OH</sub>	Output High Voltage [2]	V <sub>HIGH</sub> = 900mV, Fast Slew Rate, 156.25MHz, 312.5MHz. (Slow slew rate is not recommended for frequencies > 100MHz)	756	890	1024	mV
V <sub>OL</sub>	Output Low Voltage [2]		-85	31	147	
V <sub>CROSS</sub>	Crossing Voltage (abs) [3]		269	405	541	
ΔV <sub>CROSS</sub>	Crossing Voltage (var) [3][4][5]		0	47	144	
t <sub>R</sub>	Rise Time [2] VT = 20% to 80% of swing		222	412	610	ps
t <sub>F</sub>	Fall Time [2] VT = 20% to 80% of swing		127	368	591	ps
t <sub>DC</sub>	Output Duty Cycle [6]	Across all settings in this table, V <sub>T</sub> = 0V.	48.2	48.9	50.3	%

- Standard high impedance load with C<sub>L</sub> = 2pF. For more information, see [Test Loads](#).
- Measured from single-ended waveform.
- Measured at crossing point where the instantaneous voltage value of the rising edge of CLK equals the falling edge of CLKb.
- Refers to the total variation from the lowest crossing point to the highest, regardless of which edge is crossing. Refers to all crossing points for this measurement.
- Defined as the total variation of all crossing voltages of Rising CLK and Falling CLKb. This is the maximum allowed variance in VCROSS for any particular system.
- Measured from differential waveform.

**Table 20. RC1901xA/RC1900xA 100Ω CLK AC/DC Characteristics–Non-PCIe Apps, Double-Terminated Loads [1]**

Symbol	Parameter	Condition	Minimum	Typical	Maximum	Unit
V <sub>OH</sub>	Output High Voltage [2]	V <sub>HIGH</sub> = 800mV, Fast Slew Rate, 156.25MHz, 312.5MHz - amplitude is reduced by ~50% due to double termination. (Slow slew rate is not recommended for frequencies > 100MHz)	365	398	435	mV
V <sub>OL</sub>	Output Low Voltage [2]		-20	10	43	
V <sub>CROSS</sub>	Crossing Voltage (abs) [3]		152	186	216	
ΔV <sub>CROSS</sub>	Crossing Voltage (var) [3][4][5]		-14	7	29	
t <sub>R</sub>	Rise Time [2] VT = 20% to 80% of swing		237	409	634	ps
t <sub>F</sub>	Fall Time [2] VT = 20% to 80% of swing		174	260	380	ps

**Table 20. RC1901xA/RC1900xA 100Ω CLK AC/DC Characteristics–Non-PCIe Apps, Double-Terminated Loads [1]**

Symbol	Parameter	Condition	Minimum	Typical	Maximum	Unit
V <sub>OH</sub>	Output High Voltage [2]	V <sub>HIGH</sub> = 900mV, Fast Slew Rate, 156.25MHz, 312.5MHz - amplitude is reduced by ~50% due to double termination. (Slow slew rate is not recommended for frequencies >100MHz)	405	442	485	mV
V <sub>OL</sub>	Output Low Voltage [2]		-22	12	45	
V <sub>CROSS</sub>	Crossing Voltage (abs) [3]		167	201	232	
ΔV <sub>CROSS</sub>	Crossing Voltage (var) [3][4][5]		-14	8	30	
t <sub>R</sub>	Rise Time [2] VT = 20% to 80% of swing		280	467	695	ps
t <sub>F</sub>	Fall Time [2] VT = 20% to 80% of swing		180	263	385	ps
t <sub>DC</sub>	Output Duty Cycle [6]	Across all settings in this table, V <sub>T</sub> = 0V.	49	50	51	%

- Both Tx and Rx are terminated (double-terminated) with C<sub>L</sub> = 2pF. This reduces amplitude by 50%. For more information, see [Test Loads](#).
- Measured from single-ended waveform.
- Measured at crossing point where the instantaneous voltage value of the rising edge of CLK equals the falling edge of CLKb.
- Refers to the total variation from the lowest crossing point to the highest, regardless of which edge is crossing. Refers to all crossing points for this measurement.
- Defined as the total variation of all crossing voltages of Rising CLK and Falling CLKb. This is the maximum allowed variance in VCROSS for any particular system.
- Measured from differential waveform.

### 2.5.5 Output-to-Output and Input-to-Output Skew

**Table 21. RC1902xA Output-to-Output and Input-to-Output Skew [1]**

Symbol	Parameter	Condition	Minimum	Typical	Maximum	Unit
t <sub>SK</sub>	Output-to-Output Skew [2]	Any two outputs, all outputs at fast slew rate.	-	38	50	ps
		Any two outputs, all outputs at slow slew rate.	-	40	60	ps
t <sub>PD</sub>	Input-to-Output Delay Double-Terminated [3]	Clock in to any output, all outputs at fast slew rate.	1.1	1.2	1.4	ns
		Clock in to any output, all outputs at slow slew rate.	1.2	1.4	1.6	ns
t <sub>PD</sub>	Input-to-Output Delay Source-Terminated [3]	Clock in to any output, all outputs at fast slew rate.	1.2	1.4	1.6	ns
		Clock in to any output, all outputs at slow slew rate.	1.4	1.5	1.8	ns
Δt <sub>PD</sub>	Input-to-Output Delay Variation [3]	A single device, over temperature <i>and</i> voltage.	-	1.4	2	ps/°C

- For more information, see [Test Loads](#).
- This parameter is defined in accordance with JEDEC Standard 65.
- Defined as the time between to output rising edge and the input rising edge that caused it.

Table 22. RC1901xA/RC1900xA Output-to-Output and Input-to-Output Skew [1]

Symbol	Parameter	Condition	Minimum	Typical	Maximum	Unit
$t_{SK}$	Output-to-Output Skew [2]	Any two outputs, all outputs at fast slew rate.	-	37	50	ps
		Any two outputs, all outputs at slow slew rate.	-	39	60	ps
$t_{PD}$	Input-to-Output Delay Double-Terminated [3]	Clock in to any output, all outputs at fast slew rate.	1.1	1.4	1.6	ns
		Clock in to any output, all outputs at slow slew rate.	1.2	1.5	1.8	ns
$t_{PD}$	Input-to-Output Delay Source-Terminated [3]	Clock in to any output, all outputs at fast slew rate.	1.2	1.4	1.7	ns
		Clock in to any output, all outputs at slow slew rate.	1.3	1.5	1.8	ns
$\Delta t_{PD}$	Input-to-Output Delay Variation [3]	A single device, over temperature <i>and</i> voltage.	-	1.5	1.8	ps/°C

1. For more information, see [Test Loads](#).
2. This parameter is defined in accordance with JEDEC Standard 65.
3. Defined as the time between to output rising edge and the input rising edge that caused it.

## 2.5.6 I/O Signals

Table 23. I/O Electrical Characteristics

Symbol	Parameter	Condition	Minimum	Typical	Maximum	Unit
$V_{IH}$	Input High Voltage [1][2]	Single-ended inputs, unless otherwise listed.	2	-	VDD + 0.3	V
$V_{IL}$	Input Low Voltage [1][2]		-0.3	-	0.8	V
$V_{IH}$	Input High Voltage	SADR_tri[1:0].	2.4	-	VDD+0.3	V
$V_{IM}$	Input Mid Voltage		1.2	-	1.8	V
$V_{IL}$	Input Low Voltage		-0.3	-	0.8	V
$V_{OH}$	Output High Voltage [2]	SBI_OUT, IOH = -2mA	2.4	3.2	VDD + 0.3	V
$V_{OL}$	Output Low Voltage [2]	SBI_OUT, IOL = 2mA	-	0.1	0.4	V
$I_{IH}$	Input Leakage Current High, $V_{IN} = VDD$	CLKIN (RC19020A, RC19020A072)	-3	-	+3	$\mu A$
		CLKINb (RC19020A, RC19020A072)	5	-	15	
		CLKIN (All other devices)	5	-	15	
		CLKINb (All other devices)	-3	-	+3	
		Single-ended inputs, unless otherwise listed (including PWRGD_PWRDNb for RC19020A).	25	-	35	
		PWRGD_PWRDNb (all devices except RC19020A)	-1	-	5	
		SADR_tri[1:0]	25	-	35	

**Table 23. I/O Electrical Characteristics (Cont.)**

Symbol	Parameter	Condition	Minimum	Typical	Maximum	Unit
I <sub>IL</sub>	Input Leakage Current Low, V <sub>IN</sub> = 0V	CLKIN (RC19020A, RC19020A072)	-12	-	-6	μA
		CLKINb (RC19020A, RC19020A072)	-3	-	+3	
		CLKIN (All other devices)	-3	-	+3	
		CLKINb (All other devices)	-12	-	-6	
		Single-ended inputs, unless otherwise listed (including PWRGD_PWRDNb for RC19020A).	-3	-	+3	
		PWRGD_PWRDNb (all devices except RC19020A).	-35	-	-20	
		SADR_tri[1:0]	-35	-	-20	
R <sub>p</sub>	PD_CLKIN	Value of internal pull-down resistor to ground (CLKIN)	-	53	-	kΩ
	PU_CLKINb	Value of internal pull-up resistor to 0.5V (CLKINb).	-	57	-	
	Pull-up/Pull-down Resistor	Single-ended inputs.	-	125	-	
Z <sub>o</sub>	Output Impedance	SBI_OUT pin.	-	50	-	Ω
		CLK outputs, RC190xxA (single-ended value).	-	41	-	Ω
		CLK outputs, RC190xxA100 (single-ended value).	-	48	-	Ω

1. For SCLK and SDATA, see the SMBus Electrical Characteristics table.
2. These values are compliant with JESD8C.01.

## 2.5.7 Power Supply Current

**Table 24. Power Supply Current [1][2][3]**

Symbol	Parameter	Condition	Minimum	Typical	Maximum	Unit
I <sub>DDCLK</sub>	V <sub>DDCLK</sub> Operating Current – RC19024A	85Ω impedance, fast slew rate, source-terminated load at 100MHz. PWRGD_PWRDNb = 1.	-	245	267	mA
		85Ω impedance, fast slew rate, double-terminated load at 100MHz. PWRGD_PWRDNb = 1.	-	303	323	
		85Ω impedance, fast slew rate, source-terminated load at maximum output frequency. PWRGD_PWRDNb = 1.	-	421	448	
		85Ω impedance, fast slew rate, double-terminated load at maximum output frequency. PWRGD_PWRDNb = 1.	-	484	504	

Table 24. Power Supply Current [1][2][3] (Cont.)

Symbol	Parameter	Condition	Minimum	Typical	Maximum	Unit
I <sub>DDCLK</sub>	V <sub>DDCLK</sub> Operating Current – RC19020A	85Ω impedance, fast slew rate, source-terminated load at 100MHz. PWRGD_PWRDNb = 1.	-	217	233	mA
		85Ω impedance, fast slew rate, double-terminated load at 100MHz. PWRGD_PWRDNb = 1.	-	262	279	
		85Ω impedance, fast slew rate, source-terminated load at maximum output frequency. PWRGD_PWRDNb = 1.	-	362	381	
		85Ω impedance, fast slew rate, double-terminated load at maximum output frequency. PWRGD_PWRDNb = 1.	-	420	439	
I <sub>DDCLK</sub>	V <sub>DDCLK</sub> Operating Current – RC19020A072	85Ω impedance, fast slew rate, source-terminated load at 100MHz. PWRGD_PWRDNb = 1.	-	224	246	mA
		85Ω impedance, fast slew rate, double-terminated load at 100MHz. PWRGD_PWRDNb = 1.	-	254	276	
		85Ω impedance, fast slew rate, source-terminated load at maximum output frequency. PWRGD_PWRDNb = 1.	-	343	355	
		85Ω impedance, fast slew rate, double-terminated load at maximum output frequency. PWRGD_PWRDNb = 1.	-	402	414	
I <sub>DDCLK</sub>	V <sub>DDCLK</sub> Operating Current – RC19016A	85Ω impedance, fast slew rate, source-terminated load at 100MHz. PWRGD_PWRDNb = 1.	-	154	175	mA
		85Ω impedance, fast slew rate, double-terminated load at 100MHz. PWRGD_PWRDNb = 1.	-	210	231	
		85Ω impedance, fast slew rate, source-terminated load at maximum output frequency. PWRGD_PWRDNb = 1.	-	270	291	
		85Ω impedance, fast slew rate, double-terminated load at maximum output frequency. PWRGD_PWRDNb = 1.	-	336	357	
I <sub>DDCLK</sub>	V <sub>DDCLK</sub> Operating Current – RC19013A	85Ω impedance, fast slew rate, source-terminated load at 100MHz. PWRGD_PWRDNb = 1.	-	110	131	mA
		85Ω impedance, fast slew rate, double-terminated load at 100MHz. PWRGD_PWRDNb = 1.	-	174	194	
		85Ω impedance, fast slew rate, source-terminated load at maximum output frequency. PWRGD_PWRDNb = 1.	-	215	236	
		85Ω impedance, fast slew rate, double-terminated load at maximum output frequency. PWRGD_PWRDNb = 1.	-	276	297	



Table 24. Power Supply Current [1][2][3] (Cont.)

Symbol	Parameter	Condition	Minimum	Typical	Maximum	Unit
I <sub>DDCLK</sub>	V <sub>DDCLK</sub> Operating Current – RC19008A	85Ω impedance, fast slew rate, source-terminated load at 100MHz. PWRGD_PWRDNb = 1.	-	72	92	mA
		85Ω impedance, fast slew rate, double-terminated load at 100MHz. PWRGD_PWRDNb = 1.	-	116	137	
		85Ω impedance, fast slew rate, source-terminated load at maximum output frequency. PWRGD_PWRDNb = 1.	-	126	146	
		85Ω impedance, fast slew rate, double-terminated load at maximum output frequency. PWRGD_PWRDNb = 1.	-	183	203	
I <sub>DDCLK</sub>	V <sub>DDCLK</sub> Operating Current – RC19004A	85Ω impedance, fast slew rate, source-terminated load at 100MHz. PWRGD_PWRDNb = 1.	-	39	59	mA
		85Ω impedance, fast slew rate, double-terminated load at 100MHz. PWRGD_PWRDNb = 1.	-	60	80	
		85Ω impedance, fast slew rate, source-terminated load at maximum output frequency. PWRGD_PWRDNb = 1.	-	79	100	
		85Ω impedance, fast slew rate, double-terminated load at maximum output frequency. PWRGD_PWRDNb = 1.	-	102	122	
I <sub>DDCLK</sub>	V <sub>DDCLK</sub> Operating Current – RC19016A100	100Ω impedance, fast slew rate, source-terminated load at 100MHz. PWRGD_PWRDNb = 1.	-	151	172	mA
		100Ω impedance, fast slew rate, double-terminated load at 100MHz. PWRGD_PWRDNb = 1.	-	187	208	
		100Ω impedance, fast slew rate, source-terminated load at maximum output frequency. PWRGD_PWRDNb = 1.	-	265	285	
		100Ω impedance, fast slew rate, double-terminated load at maximum output frequency. PWRGD_PWRDNb = 1.	-	303	323	
I <sub>DDCLK</sub>	V <sub>DDCLK</sub> Operating Current – RC19013A100	100Ω impedance, fast slew rate, source-terminated load at 100MHz. PWRGD_PWRDNb = 1.	-	97	117	mA
		100Ω impedance, fast slew rate, double-terminated load at 100MHz. PWRGD_PWRDNb = 1.	-	160	180	
		100Ω impedance, fast slew rate, source-terminated load at maximum output frequency. PWRGD_PWRDNb = 1.	-	194	214	
		100Ω impedance, fast slew rate, double-terminated load at maximum output frequency. PWRGD_PWRDNb = 1.	-	257	278	

Table 24. Power Supply Current [1][2][3] (Cont.)

Symbol	Parameter	Condition	Minimum	Typical	Maximum	Unit
I <sub>DDCLK</sub>	V <sub>DDCLK</sub> Operating Current – RC19008A100	100Ω impedance, fast slew rate, source-terminated load at 100MHz. PWRGD_PWRDNb = 1.	-	70	90	mA
		100Ω impedance, fast slew rate, double-terminated load at 100MHz. PWRGD_PWRDNb = 1.	-	106	126	
		100Ω impedance, fast slew rate, source-terminated load at maximum output frequency. PWRGD_PWRDNb = 1.	-	121	142	
		100Ω impedance, fast slew rate, double-terminated load at maximum output frequency. PWRGD_PWRDNb = 1.	-	169	190	
I <sub>DDCLK</sub>	V <sub>DDCLK</sub> Operating Current – RC19004A100	100Ω impedance, fast slew rate, source-terminated load at 100MHz. PWRGD_PWRDNb = 1.	-	38	59	mA
		100Ω impedance, fast slew rate, double-terminated load at 100MHz. PWRGD_PWRDNb = 1.	-	59	79	
		100Ω impedance, fast slew rate, source-terminated load at maximum output frequency. PWRGD_PWRDNb = 1.	-	74	94	
		100Ω impedance, fast slew rate, double-terminated load at maximum output frequency. PWRGD_PWRDNb = 1.	-	97	118	
I <sub>DDDIG</sub>	V <sub>DDDIG</sub> Operating Current	PWRGD_PWRDNb = 1, RC19024A/RC19016A/13A/08A/04A.	-	0.6	1.3	mA
I <sub>DDR</sub>	V <sub>DDR</sub> Operating Current	PWRGD_PWRDNb = 1, RC19020A, RC19020A072	-	0.6	1.3	mA
I <sub>DDCLK_PD</sub>	V <sub>DDCLK</sub> Power-down Current	PWRGD_PWRDNb = 0, RC19016A/13A/08A/04A.	-	0.6	1.3	mA
		PWRGD_PWRDNb = 0, RC19024A, RC19020A, RC19020A072	-	3.5	5.0	mA
I <sub>DDDIG_PD</sub>	V <sub>DDDIG</sub> Power-down Current	PWRGD_PWRDNb = 0, RC19024A/RC19016A/13A/08A/04A.	-	3.1	5.0	mA
I <sub>DDR_PD</sub>	V <sub>DDR</sub> Power-down Current	PWRGD_PWRDNb = 0, RC19020A, RC19020A072	-	0.6	1.3	mA

1. For more information, see [Test Loads](#).
2. Output voltage set to 800mV. Slew rate has negligible effect on current consumption, so only fast is listed.
3. Total operating current is obtained by adding I<sub>DDCLK</sub> + I<sub>DDDIG</sub>, or I<sub>DDCLK</sub> + I<sub>DDR</sub> for a particular device and operating mode. Power down current is obtained by adding I<sub>DDCLK\_PD</sub> + I<sub>DDDIG\_PD</sub>, or I<sub>DDCLK\_PD</sub> + I<sub>DDR\_PD</sub> for a particular device.

### 2.5.8 CLKIN AC/DC Characteristics

Table 25. CLKIN AC/DC Characteristic

Symbol	Parameter	Condition	Minimum [1]	Typical	Maximum	Unit
V <sub>CROSS</sub>	Input Crossover Voltage	-	100	-	1400	mV
V <sub>SWING</sub>	Input Swing	Differential value.	200	-	-	mV
dv/dt	Input Slew Rate	Measured differentially. [2]	0.6	-	-	V/ns

- For values required for performance, see the [Phase Jitter](#) tables.
- Measured from -150mV to +150mV on the differential waveform (derived from REFCLK+ minus REFCLK-). The signal must be monotonic through the measurement region for rise and fall time. The 300mV measurement window is centered on the differential zero-crossing.

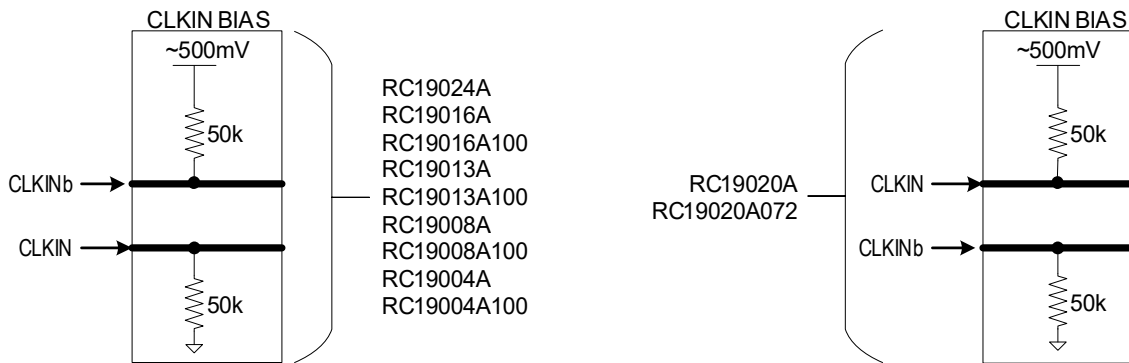

Figure 9. Clock Input Bias Network

### 2.5.9 SMBus Electrical Characteristics

Table 26. SMBus DC Electrical Characteristics [1]

Symbol	Parameter	Condition	Minimum	Typical	Maximum	Unit
V <sub>IH</sub>	High-level Input Voltage for SMBCLK and SMBDAT	-	0.8 VDD	-	-	V
V <sub>IL</sub>	Low-level Input Voltage for SMBCLK and SMBDAT	-	-	-	0.3 VDD	
V <sub>HYS</sub>	Hysteresis of Schmitt Trigger Inputs	-	0.05 VDD	-	-	
V <sub>OL</sub>	Low-level Output Voltage for SMBCLK and SMBDAT	I <sub>OL</sub> = 4mA	-	0.28	0.4	
I <sub>IN</sub>	Input Leakage Current per Pin	-	[2]	-	[2]	μA
C <sub>B</sub>	Capacitive Load for Each Bus Line	-	-	-	400	pF

- V<sub>OH</sub> is governed by the V<sub>PUP</sub>, the voltage rail to which the pull-up resistors are connected.
- For more information, see [I/O Electrical Characteristics](#).

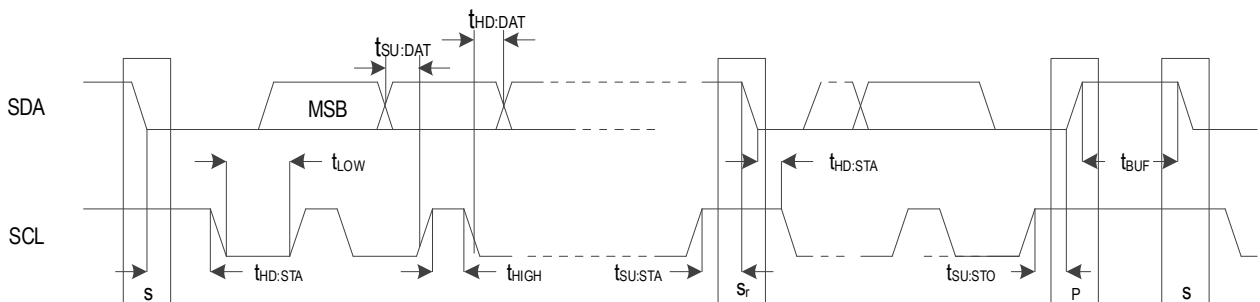

Figure 10. SMBus Slave Timing Diagram

Table 27. SMBus AC Electrical Characteristics

Symbol	Parameter	Condition	100kHz Class		400kHz Class		Unit
			Minimum	Maximum	Minimum	Maximum	
$f_{SMB}$	SMBus Operating Frequency	[1]	10	100	10	400	kHz
$t_{BUF}$	Bus free time between STOP and START Condition	-	4.7	-	1.3	-	$\mu$ s
$t_{HD:STA}$	Hold Time after (REPEATED) START Condition	[2]	4	-	0.6	-	$\mu$ s
$t_{SU:STA}$	REPEATED START Condition Setup Time	-	4.7	-	0.6	-	$\mu$ s
$t_{SU:STO}$	STOP Condition Setup Time	-	4	-	0.6	-	$\mu$ s
$t_{HD:DAT}$	Data Hold Time	[3]	300	-	300	-	ns
$t_{SU:DAT}$	Data Setup Time	-	250	-	100	-	ns
$t_{TIMEOUT}$	Detect SCL_SCLK Low Timeout	[4]	25	35	25	35	ms
$t_{TIMEOUT}$	Detect SDA_nCS Low Timeout	[5]	25	35	25	35	ms
$t_{LOW}$	Clock Low Period	-	4.7	-	1.3	-	$\mu$ s
$t_{HIGH}$	Clock High Period	[6]	4	50	0.6	50	$\mu$ s
$t_{LOW:SEXT}$	Cumulative Clock Low Extend Time - Slave	[7]	N/A		N/A		ms
$t_{LOW:MEXT}$	Cumulative Clock Low Extend Time - Master	[8]	N/A		N/A		ms
$t_F$	Clock/Data Fall Time	[9]	-	300	-	300	ns
$t_R$	Clock/Data Rise Time	[9]	-	1000	-	300	ns
$t_{SPIKE}$	Noise Spike Suppression Time	[10]	-	-	0	50	ns

1. Power must be applied and PWRGD\_PWRDNb must be a 1 for the SMBus to be active.
2. A master should not drive the clock at a frequency below the minimum  $f_{SMB}$ . Further, the operating clock frequency should not be reduced below the minimum value of  $f_{SMB}$  due to periodic clock extending by slave devices as defined in Section 5.3.3 of System Management Bus (SMBus) Specification, Version 3.1, dated 19 Mar 2018. This limit does not apply to the bus idle condition, and this limit is independent from the  $t_{LOW:SEXT}$  and  $t_{LOW:MEXT}$  limits. For example, if the SMBCLK is high for  $t_{HIGH,MAX}$ , the clock must not be periodically stretched longer than  $1/f_{SMB,MIN} - t_{HIGH,MAX}$ . This requirement does not pertain to a device that extends the SMBCLK low for data processing of a received byte, data buffering and so forth for longer than 100  $\mu$ s in a non-periodic way.
3. A device must internally provide sufficient hold time for the SMBDAT signal (with respect to the  $V_{IH,MIN}$  of the SMBCLK signal) to bridge the undefined region of the falling edge of SMBCLK.
4. Slave devices may have caused other slave devices to hold SDA low. This is the maximum time that a device can hold SMBDAT low after the master raises SMBCLK after the last bit of a transaction. A slave device may detect how long SDA is held low and release SDA after the time out period.
5. Devices participating in a transfer can abort the transfer in progress and release the bus when any single clock low interval exceeds the value of  $t_{TIMEOUT,MIN}$ . After the master in a transaction detects this condition, it must generate a stop condition within or after the current data byte in the transfer process. Devices that have detected this condition must reset their communication and be able to receive a new START condition no later than  $t_{TIMEOUT,MAX}$ . Typical device examples include the host controller, and embedded controller, and most devices that can master the SMBus. Some simple devices do not contain a clock low drive circuit; this simple kind of device typically may reset its communications port after a start or a stop condition. A timeout condition can only be ensured if the device that is forcing the timeout holds the SMBCLK low for  $t_{TIMEOUT,MAX}$  or longer.
6. The device has the option of detecting a timeout if the SMBDATA pin is also low for this time.
7.  $t_{HIGH,MAX}$  provides a simple guaranteed method for masters to detect bus idle conditions. A master can assume that the bus is free if it detects that the clock and data signals have been high for greater than  $t_{HIGH,MAX}$ .
8.  $t_{LOW:MEXT}$  is the cumulative time a master device is allowed to extend its clock cycles within each byte of a message as defined from START-to-ACK, ACK-to-ACK, or ACK-to-STOP. It is possible that a slave device or another master will also extend the clock causing the combined clock low time to be greater than  $t_{LOW:MEXT}$  on a given byte. This parameter is measured with a full speed slave device as the sole target of the master.

9. The rise and fall time measurement limits are defined as follows:

Rise Time Limits: ( $V_{IL:MAX} - 0.15 V$ ) to ( $V_{IH:MIN} + 0.15 V$ )

Fall Time Limits: ( $V_{IH:MIN} + 0.15 V$ ) to ( $V_{IL:MAX} - 0.15 V$ )

10. Devices must provide a means to reject noise spikes of a duration up to the maximum specified value.

### 2.5.10 Side-Band Interface

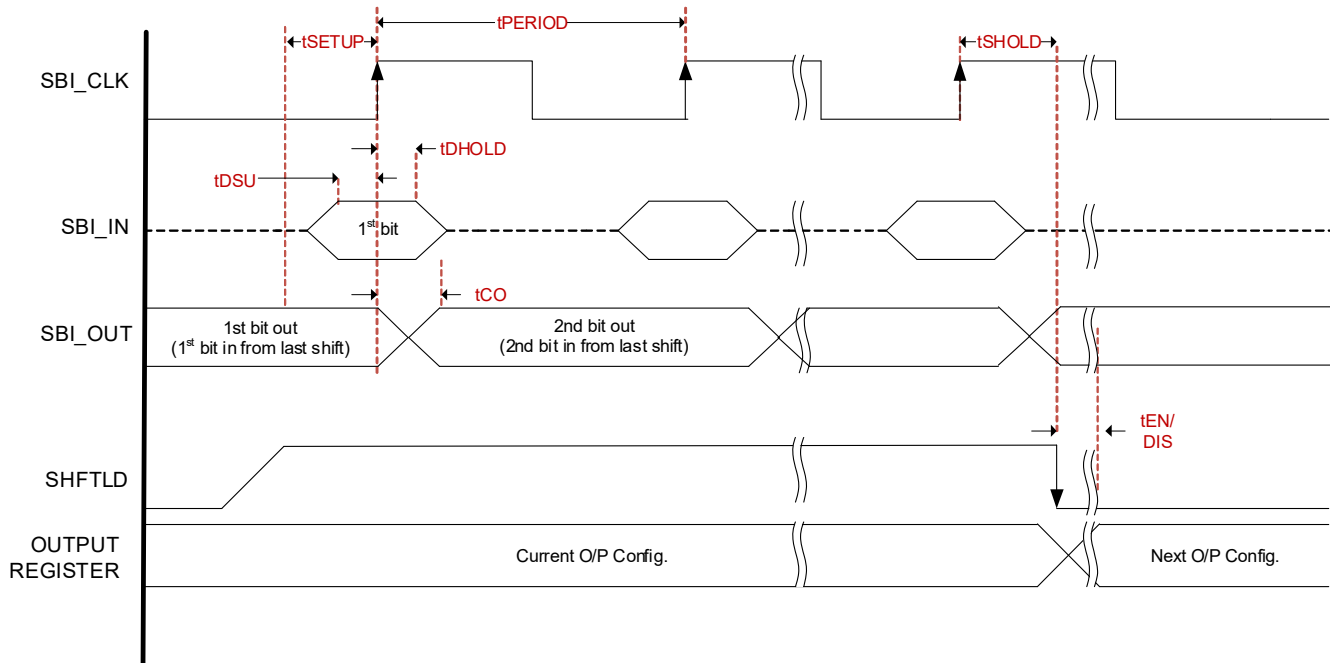

Figure 11. Side-Band Interface Timing

Figure 11 is the timing diagram and Table 28 provides the electrical characteristics for the Side-Band Interface. The SBI supports clock rates up to 25MHz.

Table 28. Electrical Characteristics – Side-Band Interface

Symbol	Parameter	Condition	Minimum	Typical	Maximum	Unit
$t_{PERIOD}$	Clock Period	Clock period.	40	-	-	ns
$t_{SETUP}$	SHFT Setup Time to Clock	SHFT_LDB high to SBI_CLK rising edge.	10	-	-	ns
$t_{DSU}$	SBI_IN Setup Time	SBI_IN setup to SBI_CLK rising edge.	5	-	-	ns
$t_{DHOLD}$	SBI_IN Hold Time	SBI_IN hold after SBI_CLK rising edge.	2	-	-	ns
$t_{CO}$	SBI_CLK to SBI_OUT	SBI_CLK rising edge to SBI_OUT valid.	2	-	-	ns
$t_{SHOLD}$	SHFT Hold Time	SHFT_LDB hold (high) after SBI_CLK rising edge (SBI_CLK to SHFT_LDB falling edge).	10	-	-	ns
$t_{EN/DIS}$	Enable/Disable Time	Delay from SHFT_LDB falling edge to next output configuration taking effect. <sup>[1]</sup>	4	-	12	clocks
$t_{SLEW}$	Slew Rate	SBI_CLK (between 20% and 80%). <sup>[2]</sup>	0.7	-	4	V/ns

1. Refers to the output clock.
2. Control input must be monotonic from 20% to 80% of input swing.

### 3. Test Loads

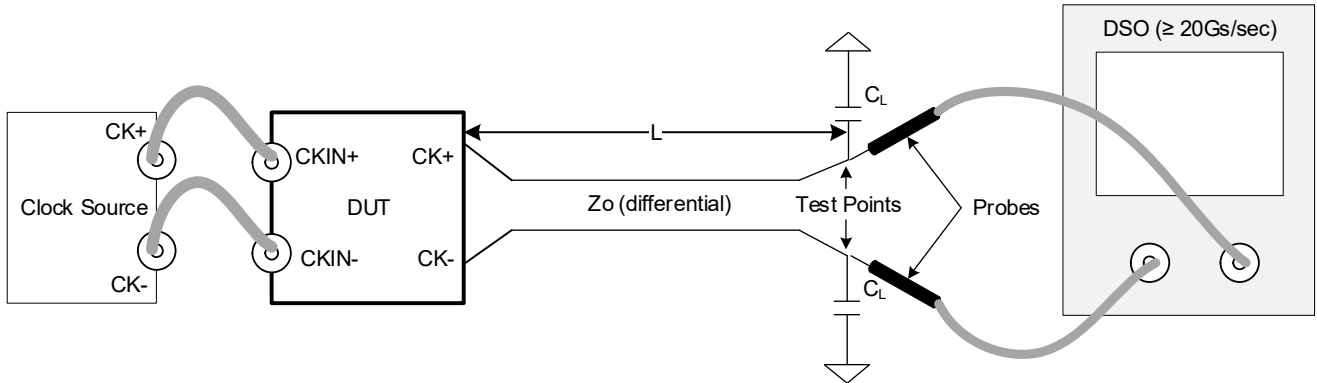

Figure 12. AC/DC Test Load for Differential Outputs (Standard PCIe Source-Terminated)

Table 29. Parameters for AC/DC Test Load (Standard PCIe Source-Terminated)

Device	Clock Source	Rs (ohms)	Zo (ohms)	L (cm)	CL (pF)
RC19xxxA	SMA100B	Internal	85	25.4	2
RC19xxxA100	SMA100B	Internal	100	25.4	2

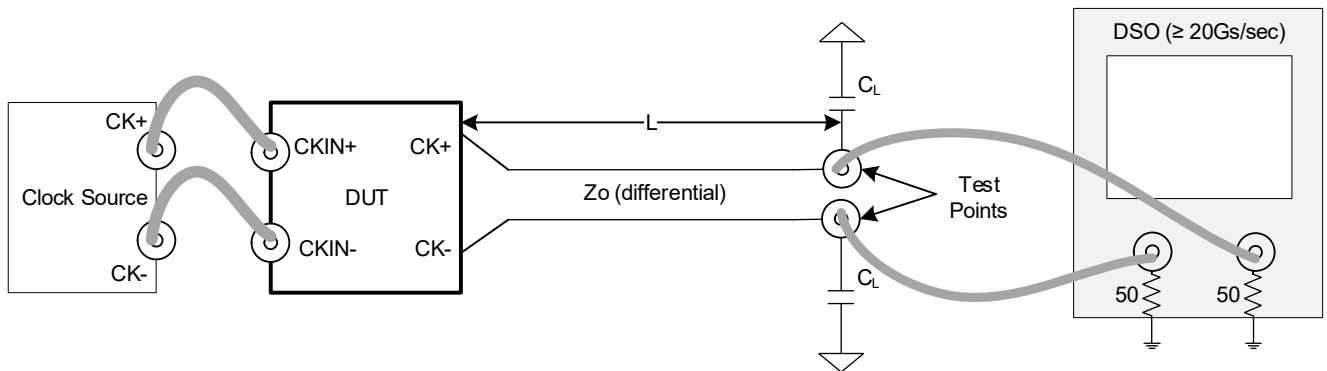

Figure 13. AC/DC Test Load for Differential Outputs (Double-Terminated)

Table 30. Parameters for AC/DC Test Load (Double-Terminated)

Device	Clock Source	Rs (ohms)	Zo (ohms)	L (cm)	CL (pF)
RC19xxxA	SMA100B	Internal	85	25.4	2
RC19xxxA100	SMA100B	Internal	100	25.4	2

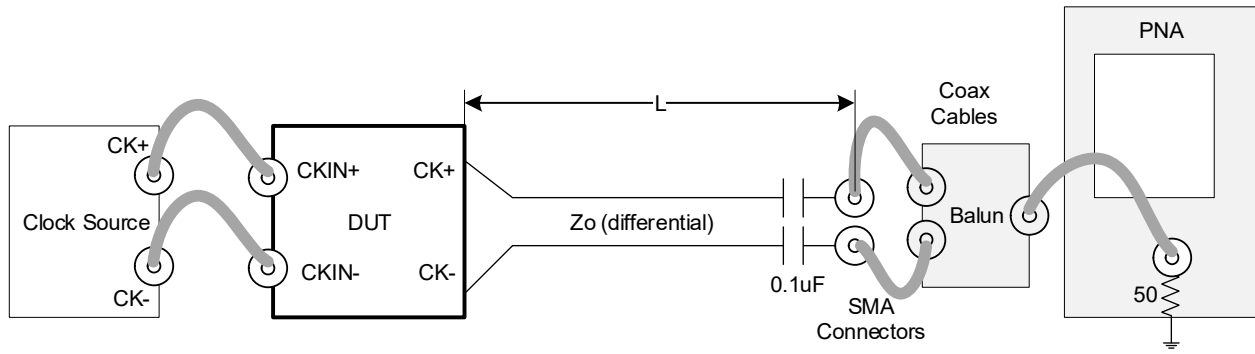

Figure 14. Test Load for PCIe Phase Jitter Measurements

Table 31. Parameters for PCIe Gen5 Jitter Measurement

Device	Clock Source	Rs (ohms)	Zo (ohms)	L (cm) [1]	CL (pF)
RC19xxxA	SMA100B	Internal	85	25.4	2
RC19xxxA100	SMA100B	Internal	100	25.4	2

1. PCIe Gen6 specifies L = 0cm for 32 and 64 GT/s. L = 25.4cm is more conservative.

## 4. General SMBus Serial Interface Information

### 4.1 How to Write

- Controller (host) sends a start bit
- Controller (host) sends the write address
- Renesas clock will **acknowledge**
- Controller (host) sends the beginning byte Location = N
- Renesas clock will **acknowledge**
- Controller (host) sends the byte count = X
- Renesas clock will **acknowledge**
- Controller (host) starts sending Byte N through **Byte N+X-1**
- Renesas clock will **acknowledge** each byte one at a time
- Controller (host) sends a stop bit

Index Block Write Operation		
Controller (Host)		Renesas (Slave/Receiver)
T	starT bit	
Slave Address		
WR	WRite	
		ACK
Beginning Byte = N		
		ACK
Data Byte Count = X		
		ACK
Beginning Byte N		
		ACK
O		X Byte
O		
O		
O		
Byte N + X - 1		
		ACK
P	stoP bit	

### 4.2 How to Read

- Controller (host) will send a start bit
- Controller (host) sends the write address
- Renesas clock will **acknowledge**
- Controller (host) sends the beginning byte Location = N
- Renesas clock will **acknowledge**
- Controller (host) will send a separate start bit
- Controller (host) sends the read address
- Renesas clock will **acknowledge**
- Renesas clock will send the data byte count = X
- Renesas clock sends Byte N+X-1
- Renesas clock sends **Byte L through Byte X (if X(H) was written to Byte 7)**
- Controller (host) will need to acknowledge each byte
- Controller (host) will send a not acknowledge bit
- Controller (host) will send a stop bit

Index Block Read Operation		
Controller (Host)		Renesas
T	starT bit	
Slave Address		
WR	WRite	
		ACK
Beginning Byte = N		
		ACK
RT	Repeat starT	
Slave Address		
RD	ReaD	
		ACK
		Data Byte Count=X
ACK		
ACK		Beginning Byte N
		O
O		O
O		O
O		
		Byte N + X - 1
N	Not	
P	stoP bit	



### 4.3 SMBus Bit Types

Bit Description	Definition
RO	Read-only
RW	Read-write
RW1C	Read/Write '1' to clear
RESERVED	Undefined do not write

### 4.4 Write Lock Functionality

WRITE_LOCK	WRITE_LOCK RW1C	SMBus Write Protect
0	0	No
0	1	Yes
1	0	Yes
1	1	Yes

### 4.5 SMBus Address Decode

Address Selection		Binary Value								Hex Value
SADR_tri1	SADR_tri0	7	6	5	4	3	2	1	Rd/Wrt	
0	0	1	1	0	1	1	0	0	0	D8
	M	1	1	0	1	1	0	1	0	DA
	1	1	1	0	1	1	1	1	0	DE
M	0	1	1	0	0	0	0	1	0	C2
	M	1	1	0	0	0	1	0	0	C4
	1	1	1	0	0	0	1	1	0	C6
1	0	1	1	0	0	1	0	1	0	CA
	M	1	1	0	0	1	1	0	0	CC
	1	1	1	0	0	1	1	1	0	CE

## 4.6 RC19024A SMBus Registers

Table 32. RC19024A SMBus Registers

Byte	Register	Name	Bit	Type	Default	Description	Definition
0	OUTPUT_ENABLE_0	CLK7_EN	[7]	RW	1	Output Enable for CLK7	0 = output is disabled (low/low) 1 = output is enabled
		CLK6_EN	[6]	RW	1	Output Enable for CLK6	
		CLK5_EN	[5]	RW	1	Output Enable for CLK5	
		CLK4_EN	[4]	RW	1	Output Enable for CLK4	
		CLK3_EN	[3]	RW	1	Output Enable for CLK3	
		CLK2_EN	[2]	RW	1	Output Enable for CLK2	
		CLK1_EN	[1]	RW	1	Output Enable for CLK1	
1	OUTPUT_ENABLE_1	CLK15_EN	[7]	RW	1	Output Enable for CLK15	0 = output is disabled (low/low) 1 = output is enabled
		CLK14_EN	[6]	RW	1	Output Enable for CLK14	
		CLK13_EN	[5]	RW	1	Output Enable for CLK13	
		CLK12_EN	[4]	RW	1	Output Enable for CLK12	
		CLK11_EN	[3]	RW	1	Output Enable for CLK11	
		CLK10_EN	[2]	RW	1	Output Enable for CLK10	
		CLK9_EN	[1]	RW	1	Output Enable for CLK9	
2	OUTPUT_ENABLE_2	CLK23_EN	[7]	RW	1	Output Enable for CLK23	0 = output is disabled (low/low) 1 = output is enabled
		CLK22_EN	[6]	RW	1	Output Enable for CLK22	
		CLK21_EN	[5]	RW	1	Output Enable for CLK21	
		CLK20_EN	[4]	RW	1	Output Enable for CLK20	
		CLK19_EN	[3]	RW	1	Output Enable for CLK19	
		CLK18_EN	[2]	RW	1	Output Enable for CLK18	
		CLK17_EN	[1]	RW	1	Output Enable for CLK17	
3	OEB_PIN_READBACK	RESERVED	[7]	RO	0	RESERVED	0 = pin low 1 = pin high
		RB_OEb23	[6]	RO	1'bX	Status of OEB23	
		RB_OEb22	[5]	RO	1'bX	Status of OEB22	
		RB_OEb2	[4]	RO	1'bX	Status of OEB2	
		RB_OEb_D	[3]	RO	1'bX	Status of OEB_D	
		RB_OEb_C	[2]	RO	1'bX	Status of OEB_C	
		RB_OEb_B	[1]	RO	1'bX	Status of OEB_B	
		RB_OEb_A	[0]	RO	1'bX	Status of OEB_A	

Table 32. RC19024A SMBus Registers (Cont.)

Byte	Register	Name	Bit	Type	Default	Description	Definition
4	SBEN_RDBK_ACP_CONFIG	RESERVED	[7:5]	RW	1'b111	-	-
		ACP_ENABLE	[4]	RW	1	Enable Automatic Clock Parking to low/low when LOS event is detected	0 = disable ACP 1 = enable ACP
		RESERVED	[3:1]	RW	1'b110	-	-
		RB_SBI_ENQ	[0]	RO	1'bX	Status of SBI_ENQ	0 = pin low 1 = pin high
5	VENDOR_REVISION_ID	RID	[7:4]	RO	0x0	REVISION ID, A rev is 0000	-
		VID	[3:0]	RO	0x1	VENDOR ID, ICS/IDT/Renesas	-
6	DEVICE_ID	DEVICE_ID	[7:0]	RO	0x18	Device ID	-
7	BYTE_COUNT	RESERVED	[7:5]	RW	0x0	RESERVED	-
		BC	[4:0]	RW	0x7	Writing to this register configures how many bytes will be read back in a block read.	-
8	SBI_MASK_0	MASK7	[7]	RW	0	Masks off Side-band Disable for CLK7	0 = SBI may disable the output 1 = SBI cannot disable the output
		MASK6	[6]	RW	0	Masks off Side-band Disable for CLK6	
		MASK5	[5]	RW	0	Masks off Side-band Disable for CLK5	
		MASK4	[4]	RW	0	Masks off Side-band Disable for CLK4	
		MASK3	[3]	RW	0	Masks off Side-band Disable for CLK3	
		MASK2	[2]	RW	0	Masks off Side-band Disable for CLK2	
		MASK1	[1]	RW	0	Masks off Side-band Disable for CLK1	
		MASK0	[0]	RW	0	Masks off Side-band Disable for CLK0	

Table 32. RC19024A SMBus Registers (Cont.)

Byte	Register	Name	Bit	Type	Default	Description	Definition
9	SBI_MASK_1	MASK15	[7]	RW	0	Masks off Side-band Disable for CLK15	0 = SBI may disable the output 1 = SBI cannot disable the output
		MASK14	[6]	RW	0	Masks off Side-band Disable for CLK14	
		MASK13	[5]	RW	0	Masks off Side-band Disable for CLK13	
		MASK12	[4]	RW	0	Masks off Side-band Disable for CLK12	
		MASK11	[3]	RW	0	Masks off Side-band Disable for CLK11	
		MASK10	[2]	RW	0	Masks off Side-band Disable for CLK10	
		MASK9	[1]	RW	0	Masks off Side-band Disable for CLK9	
		MASK8	[0]	RW	0	Masks off Side-band Disable for CLK8	
10	SBI_MASK_2	MASK23	[7]	RW	0	Masks off Side-band Disable for CLK23	0 = SBI may disable the output 1 = SBI cannot disable the output
		MASK22	[6]	RW	0	Masks off Side-band Disable for CLK22	
		MASK21	[5]	RW	0	Masks off Side-band Disable for CLK21	
		MASK20	[4]	RW	0	Masks off Side-band Disable for CLK20	
		MASK19	[3]	RW	0	Masks off Side-band Disable for CLK19	
		MASK18	[2]	RW	0	Masks off Side-band Disable for CLK18	
		MASK17	[1]	RW	0	Masks off Side-band Disable for CLK17	
		MASK16	[0]	RW	0	Masks off Side-band Disable for CLK16	

Table 32. RC19024A SMBus Registers (Cont.)

Byte	Register	Name	Bit	Type	Default	Description	Definition
11	SBI_READBACK_0 [1]	SBI_CLK7	[7]	RO	1'bX	Readback of Side-band Disable for CLK7	0 = bit low 1 = bit high
		SBI_CLK6	[6]	RO	1'bX	Readback of Side-band Disable for CLK6	
		SBI_CLK5	[5]	RO	1'bX	Readback of Side-band Disable for CLK5	
		SBI_CLK4	[4]	RO	1'bX	Readback of Side-band Disable for CLK4	
		SBI_CLK3	[3]	RO	1'bX	Readback of Side-band Disable for CLK3	
		SBI_CLK2	[2]	RO	1'bX	Readback of Side-band Disable for CLK2	
		SBI_CLK1	[1]	RO	1'bX	Readback of Side-band Disable for CLK1	
		SBI_CLK0	[0]	RO	1'bX	Readback of Side-band Disable for CLK0	
12	SBI_READBACK_1 [1]	SBI_CLK15	[7]	RO	1'bX	Readback of Side-band Disable for CLK15	0 = bit low 1 = bit high
		SBI_CLK14	[6]	RO	1'bX	Readback of Side-band Disable for CLK14	
		SBI_CLK13	[5]	RO	1'bX	Readback of Side-band Disable for CLK13	
		SBI_CLK12	[4]	RO	1'bX	Readback of Side-band Disable for CLK12	
		SBI_CLK11	[3]	RO	1'bX	Readback of Side-band Disable for CLK11	
		SBI_CLK10	[2]	RO	1'bX	Readback of Side-band Disable for CLK10	
		SBI_CLK9	[1]	RO	1'bX	Readback of Side-band Disable for CLK9	
		SBI_CLK8	[0]	RO	1'bX	Readback of Side-band Disable for CLK8	

Table 32. RC19024A SMBus Registers (Cont.)

Byte	Register	Name	Bit	Type	Default	Description	Definition
13	SBI_READBACK_2 [1]	SBI_CLK23	[7]	RO	1'bX	Readback of Side-band Disable for CLK23	0 = bit low 1 = bit high
		SBI_CLK22	[6]	RO	1'bX	Readback of Side-band Disable for CLK22	
		SBI_CLK21	[5]	RO	1'bX	Readback of Side-band Disable for CLK21	
		SBI_CLK20	[4]	RO	1'bX	Readback of Side-band Disable for CLK20	
		SBI_CLK19	[3]	RO	1'bX	Readback of Side-band Disable for CLK19	
		SBI_CLK18	[2]	RO	1'bX	Readback of Side-band Disable for CLK18	
		SBI_CLK17	[1]	RO	1'bX	Readback of Side-band Disable for CLK17	
		SBI_CLK16	[0]	RO	1'bX	Readback of Side-band Disable for CLK16	
14	OEB_ASSIGNMENT_0	CLK7_OEb_EN	[7]	RW	0	Output Enable by OEB_B	0 = output stop by OEB is disabled 1 = output stop by OEB is enabled
		CLK6_OEb_EN	[6]	RW	1	Output Enable by OEB_B	
		CLK5_OEb_EN	[5]	RW	1	Output Enable by OEB_A	
		CLK4_OEb_EN	[4]	RW	0	Output Enable by OEB_A	
		CLK3_OEb_EN	[3]	RW	0	Output Enable by OEB_A	
		CLK2_OEb_EN	[2]	RW	0	Output Enable by OEB_A	
		CLK1_OEb_EN	[1]	RW	0	Output Enable by OEB_A	
15	OEB_ASSIGNMENT_1	CLK15_OEb_EN	[7]	RW	0	Output Enable by OEB_C	0 = output stop by OEB is disabled 1 = output stop by OEB is enabled
		CLK14_OEb_EN	[6]	RW	0	Output Enable by OEB_C	
		CLK13_OEb_EN	[5]	RW	0	Output Enable by OEB_C	
		CLK12_OEb_EN	[4]	RW	0	Output Enable by OEB_C	
		CLK11_OEb_EN	[3]	RW	0	Output Enable by OEB_B	
		CLK10_OEb_EN	[2]	RW	0	Output Enable by OEB_B	
		CLK9_OEb_EN	[1]	RW	0	Output Enable by OEB_B	
		CLK8_OEb_EN	[0]	RW	0	Output Enable by OEB_B	
16	OEB_ASSIGNMENT_2	CLK23_OEb_EN	[7]	RW	0	Output Enable by OEB_D	0 = output stop by OEB is disabled 1 = output stop by OEB is enabled
		CLK22_OEb_EN	[6]	RW	0	Output Enable by OEB_D	
		CLK21_OEb_EN	[5]	RW	0	Output Enable by OEB_D	
		CLK20_OEb_EN	[4]	RW	0	Output Enable by OEB_D	
		CLK19_OEb_EN	[3]	RW	0	Output Enable by OEB_D	
		CLK18_OEb_EN	[2]	RW	1	Output Enable by OEB_D	
		CLK17_OEb_EN	[1]	RW	1	Output Enable by OEB_C	
CLK16_OEb_EN	[0]	RW	0	Output Enable by OEB_C			

Table 32. RC19024A SMBus Registers (Cont.)

Byte	Register	Name	Bit	Type	Default	Description	Definition	
17	LPHCSL_AMP_CTRL	AMP	[7:4]	RW	0x7	Global Differential output Control 0.6V~1V 25mV/step Default = 0.8V	-	
		RESERVED	[3:0]	RW	0x7	RESERVED	-	
18	PD_RESTORE_LOSb	AC_IN	[7]	RW	0	Enable receiver bias when CLKIN is AC coupled,	0 = DC coupled input 1 = AC coupled input	
		Rx_TERM	[6]	RW	0	Enable termination resistors on CLKIN	0 = input termination R is disabled 1 = input termination R is enabled	
		RESERVED	[5:4]			1'b11	-	-
		PD_RESTOREb	[3]	RW	1	Save Configuration in Power Down	0 = Config Cleared 1 = Config Saved	
		SDATA_TIMEOUT_EN	[2]	RW	1	Enable SMB SDATA time out monitoring	0 = disable SDATA time out 1 = enable SDATA time out	
		RESERVED	[1]	RO		1'bX	-	-
		LOSb_RB	[0]	RO		1'bX	real time read back of loss detect block output	0 = LOS event detected 1 = NO LOS event detected.
19	Reserved	RESERVED	[7:0]	RW	0x07	RESERVED	-	
20	OUTPUT_SLEW_RATE_0	CLK7_SLEWRATE	[7]	RW	1	CLK7 Slewrate Control	0 = low slew rate 1 = high slew rate	
		CLK6_SLEWRATE	[6]	RW	1	CLK6 Slewrate Control		
		CLK5_SLEWRATE	[5]	RW	1	CLK5 Slewrate Control		
		CLK4_SLEWRATE	[4]	RW	1	CLK4 Slewrate Control		
		CLK3_SLEWRATE	[3]	RW	1	CLK3 Slewrate Control		
		CLK2_SLEWRATE	[2]	RW	1	CLK2 Slewrate Control		
		CLK1_SLEWRATE	[1]	RW	1	CLK1 Slewrate Control		
		CLK0_SLEWRATE	[0]	RW	1	CLK0 Slewrate Control		

Table 32. RC19024A SMBus Registers (Cont.)

Byte	Register	Name	Bit	Type	Default	Description	Definition
21	OUTPUT_SLEW_RATE_1	CLK15_SLEWRATE	[7]	RW	1	CLK15 Slewrate Control	0 = low slew rate 1 = high slew rate
		CLK14_SLEWRATE	[6]	RW	1	CLK14 Slewrate Control	
		CLK13_SLEWRATE	[5]	RW	1	CLK13 Slewrate Control	
		CLK12_SLEWRATE	[4]	RW	1	CLK12 Slewrate Control	
		CLK11_SLEWRATE	[3]	RW	1	CLK11 Slewrate Control	
		CLK10_SLEWRATE	[2]	RW	1	CLK10 Slewrate Control	
		CLK9_SLEWRATE	[1]	RW	1	CLK9 Slewrate Control	
		CLK8_SLEWRATE	[0]	RW	1	CLK8 Slewrate Control	
22	OUTPUT_SLEW_RATE_2	CLK23_SLEWRATE	[7]	RW	1	CLK23 Slewrate Control	0 = low slew rate 1 = high slew rate
		CLK22_SLEWRATE	[6]	RW	1	CLK22 Slewrate Control	
		CLK21_SLEWRATE	[5]	RW	1	CLK21 Slewrate Control	
		CLK20_SLEWRATE	[4]	RW	1	CLK20 Slewrate Control	
		CLK19_SLEWRATE	[3]	RW	1	CLK19 Slewrate Control	
		CLK18_SLEWRATE	[2]	RW	1	CLK18 Slewrate Control	
		CLK17_SLEWRATE	[1]	RW	1	CLK17 Slewrate Control	
		CLK16_SLEWRATE	[0]	RW	1	CLK16 Slewrate Control	
23–37	Reserved	RESERVED		RW	0xXX	RESERVED	-
38	WRITE_LOCK_NCLEAR	RESERVED	[7:1]	RW	0x0	RESERVED	-
		WRITE_LOCK	[0]	RW	0	Non-clearable SMBus Write Lock bit. When written to one, the SMBus control registers cannot be written to. This bit can only be cleared by cycling power.	0 = SMBus not locked for writing by this bit. See WRITE_LOCK_RW1C bit. 1 = SMBus locked for writing
39	WRITE_LOCK_CLEAR_LOS_EVENT	RESERVED	[7:2]	RW1C	1'b11100 0	-	-
		LOS_EVT	[1]	RW1C	0	LOS Event Status When high, indicates that a LOS event was detected. Can be cleared by writing a 1 to it.	0 = No LOS event detected 1 = LOS event detected.
		WRITE_LOCK_RW1C	[0]	RW1C	0	Clearable SMBus Write Lock bit. When written to one, the SMBus control registers cannot be written to. This bit can be cleared by writing a 1 to it.	0 = SMBus not locked for writing by this bit. See WRITE_LOCK bit. 1 = SMBus locked for writing

1. Register only valid when the Side-Band Interface is enabled (SBI\_ENQ = 1).



## 4.7 RC19020A SMBus Registers

Table 33. RC19020A SMBus Registers

Byte	Register	Name	Bit	Type	Default	Description	Definition
0	OUTPUT_ENABLE_2	RESERVED	[7]	RW	0	RESERVED	0 = output is disabled (low/low) 1 = output is enabled
		CLK19_EN	[6]	RW	1	Output Enable for CLK19	
		CLK18_EN	[5]	RW	1	Output Enable for CLK18	
		CLK17_EN	[4]	RW	1	Output Enable for CLK17	
		CLK16_EN	[3]	RW	1	Output Enable for CLK16	
		RESERVED	[2:0]	RW	1	RESERVED	
1	OUTPUT_ENABLE_0	CLK7_EN	[7]	RW	1	Output Enable for CLK7	0 = output is disabled (low/low) 1 = output is enabled
		CLK6_EN	[6]	RW	1	Output Enable for CLK6	
		CLK5_EN	[5]	RW	1	Output Enable for CLK5	
		CLK4_EN	[4]	RW	1	Output Enable for CLK4	
		CLK3_EN	[3]	RW	1	Output Enable for CLK3	
		CLK2_EN	[2]	RW	1	Output Enable for CLK2	
		CLK1_EN	[1]	RW	1	Output Enable for CLK1	
		CLK0_EN	[0]	RW	1	Output Enable for CLK0	
2	OUTPUT_ENABLE_1	CLK15_EN	[7]	RW	1	Output Enable for CLK15	0 = output is disabled (low/low) 1 = output is enabled
		CLK14_EN	[6]	RW	1	Output Enable for CLK14	
		CLK13_EN	[5]	RW	1	Output Enable for CLK13	
		CLK12_EN	[4]	RW	1	Output Enable for CLK12	
		CLK11_EN	[3]	RW	1	Output Enable for CLK11	
		CLK10_EN	[2]	RW	1	Output Enable for CLK10	
		CLK9_EN	[1]	RW	1	Output Enable for CLK9	
		CLK8_EN	[0]	RW	1	Output Enable for CLK8	
3	OEB_PIN_READBACK	RB_OEb_12	[7]	RO	1'bX	Status of OEB12	0 = pin low 1 = pin high
		RB_OEb_11	[6]	RO	1'bX	Status of OEB11	
		RB_OEb_10	[5]	RO	1'bX	Status of OEB10	
		RB_OEb_9	[4]	RO	1'bX	Status of OEB9	
		RB_OEb_8	[3]	RO	1'bX	Status of OEB8	
		RB_OEb_7	[2]	RO	1'bX	Status of OEB7	
		RB_OEb_6	[1]	RO	1'bX	Status of OEB6	
		RB_OEb_5	[0]	RO	1'bX	Status of OEB5	
4	SBEN_RDBK_ACP_CONFIG	RESERVED	[7:5]	RW	1'b111	RESERVED	-
		ACP_ENABLE	[4]	RW	1	Enable Automatic Clock Parking to low/low when LOS event is detected	0 = disable ACP 1 = enable ACP
		RESERVED	[3:1]	RW	1'b110	RESERVED	-
		RB_SBI_ENQ	[0]	RO	1'bX	Status of SBI_ENQ	0 = pin low 1 = pin high

Table 33. RC19020A SMBus Registers (Cont.)

Byte	Register	Name	Bit	Type	Default	Description	Definition
5	VENDOR_REVISION_ID	RID	[7:4]	RO	0x2	REVISION ID, A rev is 0000	-
		VID	[3:0]	RO	0x1	VENDOR ID, ICS/IDT/Renesas	-
6	DEVICE_ID	DEVICE_ID	[7:0]	RO	0xC9	Device ID	-
7	BYTE_COUNT	RESERVED	[7:5]	RW	0x0	RESERVED	-
		BC	[4:0]	RW	0x7	Writing to this register configures how many bytes will be read back in a block read.	-
8	SBI_MASK_0	MASK7	[7]	RW	0	Masks off Side-band Disable for CLK7	0 = SBI may disable the output 1 = SBI cannot disable the output
		MASK6	[6]	RW	0	Masks off Side-band Disable for CLK6	
		MASK5	[5]	RW	0	Masks off Side-band Disable for CLK5	
		MASK4	[4]	RW	0	Masks off Side-band Disable for CLK4	
		MASK3	[3]	RW	0	Masks off Side-band Disable for CLK3	
		MASK2	[2]	RW	0	Masks off Side-band Disable for CLK2	
		MASK1	[1]	RW	0	Masks off Side-band Disable for CLK1	
		MASK0	[0]	RW	0	Masks off Side-band Disable for CLK0	
9	SBI_MASK_1	MASK15	[7]	RW	0	Masks off Side-band Disable for CLK15	0 = SBI may disable the output 1 = SBI cannot disable the output
		MASK14	[6]	RW	0	Masks off Side-band Disable for CLK14	
		MASK13	[5]	RW	0	Masks off Side-band Disable for CLK13	
		MASK12	[4]	RW	0	Masks off Side-band Disable for CLK12	
		MASK11	[3]	RW	0	Masks off Side-band Disable for CLK11	
		MASK10	[2]	RW	0	Masks off Side-band Disable for CLK10	
		MASK9	[1]	RW	0	Masks off Side-band Disable for CLK9	
		MASK8	[0]	RW	0	Masks off Side-band Disable for CLK8	

Table 33. RC19020A SMBus Registers (Cont.)

Byte	Register	Name	Bit	Type	Default	Description	Definition
10	SBI_MASK_2	RESERVED	[7:4]	RW	0	RESERVED	-
		MASK19	[3]	RW	0	Masks off Side-band Disable for CLK19	0 = SBI may disable the output 1 = SBI cannot disable the output
		MASK18	[2]	RW	0	Masks off Side-band Disable for CLK18	
		MASK17	[1]	RW	0	Masks off Side-band Disable for CLK17	
		MASK16	[0]	RW	0	Masks off Side-band Disable for CLK16	
11	OUTPUT_SLEW_RATE_0	CLK7_SLEWRATE	[7]	RW	1	CLK7 Slewrate Control	0 = low slew rate 1 = high slew rate
		CLK6_SLEWRATE	[6]	RW	1	CLK6 Slewrate Control	
		CLK5_SLEWRATE	[5]	RW	1	CLK5 Slewrate Control	
		CLK4_SLEWRATE	[4]	RW	1	CLK4 Slewrate Control	
		CLK3_SLEWRATE	[3]	RW	1	CLK3 Slewrate Control	
		CLK2_SLEWRATE	[2]	RW	1	CLK2 Slewrate Control	
		CLK1_SLEWRATE	[1]	RW	1	CLK1 Slewrate Control	
12	OUTPUT_SLEW_RATE_1	CLK15_SLEWRATE	[7]	RW	1	CLK15 Slewrate Control	0 = low slew rate 1 = high slew rate
		CLK14_SLEWRATE	[6]	RW	1	CLK14 Slewrate Control	
		CLK13_SLEWRATE	[5]	RW	1	CLK13 Slewrate Control	
		CLK12_SLEWRATE	[4]	RW	1	CLK12 Slewrate Control	
		CLK11_SLEWRATE	[3]	RW	1	CLK11 Slewrate Control	
		CLK10_SLEWRATE	[2]	RW	1	CLK10 Slewrate Control	
		CLK9_SLEWRATE	[1]	RW	1	CLK9 Slewrate Control	
		CLK8_SLEWRATE	[0]	RW	1	CLK8 Slewrate Control	
13	OUTPUT_SLEW_RATE_2	RESERVED	[7:4]	RW	0b111	RESERVED	0 = low slew rate 1 = high slew rate
		CLK19_SLEWRATE	[3]	RW	1	CLK19 Slewrate Control	
		CLK18_SLEWRATE	[2]	RW	1	CLK18 Slewrate Control	
		CLK17_SLEWRATE	[1]	RW	1	CLK17 Slewrate Control	
		CLK16_SLEWRATE	[0]	RW	1	CLK16 Slewrate Control	
14 - 19	RESERVED	-	-	-	-	RESERVED	-
20	LPHCSL_AMP_CTRL	AMP	[7:4]	RW	0x7	Global Differential output Control 0.6V~1V 25mV/step Default = 0.8V	-
		RESERVED	[3:0]	RW	0x7	RESERVED	-

Table 33. RC19020A SMBus Registers (Cont.)

Byte	Register	Name	Bit	Type	Default	Description	Definition
21	PD_RESTORE_LOSb	AC_IN	[7]	RW	0	Enable receiver bias when CLKIN is AC coupled,	0 = DC coupled input 1 = AC coupled input
		Rx_TERM	[6]	RW	0	Enable termination resistors on CLKIN	0 = input termination R is disabled 1 = input termination R is enabled
		RESERVED	[5:4]	-	1'b11	-	-
		PD_RESTOREb	[3]	RW	1	Save Configuration in Power Down	0 = Config Cleared 1 = Config Saved
		SDATA_TIMEOUT_EN	[2]	RW	1	Enable SMB SDATA time out monitoring	0 = disable SDATA time out 1 = enable SDATA time out
		RESERVED	[1]	RO	1'bX	-	-
		LOSb_RB	[0]	RO	1'bX	real time read back of loss detect block output	0 = LOS event detected 1 = NO LOS event detected.
22–32	RESERVED	RESERVED	[7:0]	RW	0xXX	RESERVED	-
33	SBI_READBACK_0 <sup>[1]</sup>	SBI_CLK7	[7]	RO	1'bX	Readback of Side-band Disable for CLK7	0 = bit low 1 = bit high
		SBI_CLK6	[6]	RO	1'bX	Readback of Side-band Disable for CLK6	
		SBI_CLK5	[5]	RO	1'bX	Readback of Side-band Disable for CLK5	
		SBI_CLK4	[4]	RO	1'bX	Readback of Side-band Disable for CLK4	
		SBI_CLK3	[3]	RO	1'bX	Readback of Side-band Disable for CLK3	
		SBI_CLK2	[2]	RO	1'bX	Readback of Side-band Disable for CLK2	
		SBI_CLK1	[1]	RO	1'bX	Readback of Side-band Disable for CLK1	
		SBI_CLK0	[0]	RO	1'bX	Readback of Side-band Disable for CLK0	

Table 33. RC19020A SMBus Registers (Cont.)

Byte	Register	Name	Bit	Type	Default	Description	Definition
34	SBI_READBACK_1 [1]	SBI_CLK15	[7]	RO	1'bX	Readback of Side-band Disable for CLK15	0 = bit low 1 = bit high
		SBI_CLK14	[6]	RO	1'bX	Readback of Side-band Disable for CLK14	
		SBI_CLK13	[5]	RO	1'bX	Readback of Side-band Disable for CLK13	
		SBI_CLK12	[4]	RO	1'bX	Readback of Side-band Disable for CLK12	
		SBI_CLK11	[3]	RO	1'bX	Readback of Side-band Disable for CLK11	
		SBI_CLK10	[2]	RO	1'bX	Readback of Side-band Disable for CLK10	
		SBI_CLK9	[1]	RO	1'bX	Readback of Side-band Disable for CLK9	
		SBI_CLK8	[0]	RO	1'bX	Readback of Side-band Disable for CLK8	
35	SBI_READBACK_2 [1]	RESERVED	[7:4]	RO	1'bXXX	RESERVED	0 = bit low 1 = bit high
		SBI_CLK19	[3]	RO	1'bX	Readback of Side-band Disable for CLK19	
		SBI_CLK18	[2]	RO	1'bX	Readback of Side-band Disable for CLK18	
		SBI_CLK17	[1]	RO	1'bX	Readback of Side-band Disable for CLK17	
		SBI_CLK16	[0]	RO	1'bX	Readback of Side-band Disable for CLK16	
36-37	RESERVED	RESERVED	[7:0]	RW	0xXX	RESERVED	RESERVED
38	WRITE_LOCK_NCLEAR	RESERVED	[7:1]	RW	0x0	RESERVED	-
		WRITE_LOCK	[0]	RW	0	Non-clearable SMBus Write Lock bit. When written to one, the SMBus control registers cannot be written to. This bit can only be cleared by cycling power.	0 = SMBus not locked for writing by this bit. See WRITE_LOCK_RW1C bit. 1 = SMBus locked for writing
39	WRITE_LOCK_CLEAR_LOS_EVENT	RESERVED	[7:2]	RW1C	1'b11100 0	-	-
		LOS_EVT	[1]	RW1C	0	LOS Event Status When high, indicates that a LOS event was detected. Can be cleared by writing a 1 to it.	0 = No LOS event detected 1 = LOS event detected.
		WRITE_LOCK_RW1C	[0]	RW1C	0	Clearable SMBus Write Lock bit. When written to one, the SMBus control registers cannot be written to. This bit can be cleared by writing a 1 to it.	0 = SMBus not locked for writing by this bit. See WRITE_LOCK bit. 1 = SMBus locked for writing

1. Register only valid when the Side-Band Interface is enabled (SBI\_ENQ = 1).

## 4.8 RC19020A072 SMBus Registers

Table 34. RC19020A072 SMBus Registers

Byte	Register	Name	Bit	Type	Default	Description	Definition
0	OUTPUT_ENABLE_2	RESERVED	[7]	RW	0	RESERVED	0 = output is disabled (low/low) 1 = output is enabled
		CLK19_EN	[6]	RW	1	Output Enable for CLK19	
		CLK18_EN	[5]	RW	1	Output Enable for CLK18	
		CLK17_EN	[4]	RW	1	Output Enable for CLK17	
		CLK16_EN	[3]	RW	1	Output Enable for CLK16	
		RESERVED	[2:0]	RW	0	RESERVED	
1	OUTPUT_ENABLE_0	CLK7_EN	[7]	RW	1	Output Enable for CLK7	0 = output is disabled (low/low) 1 = output is enabled
		CLK6_EN	[6]	RW	1	Output Enable for CLK6	
		CLK5_EN	[5]	RW	1	Output Enable for CLK5	
		CLK4_EN	[4]	RW	1	Output Enable for CLK4	
		CLK3_EN	[3]	RW	1	Output Enable for CLK3	
		CLK2_EN	[2]	RW	1	Output Enable for CLK2	
		CLK1_EN	[1]	RW	1	Output Enable for CLK1	
		CLK0_EN	[0]	RW	1	Output Enable for CLK0	
2	OUTPUT_ENABLE_1	CLK15_EN	[7]	RW	1	Output Enable for CLK15	0 = output is disabled (low/low) 1 = output is enabled
		CLK14_EN	[6]	RW	1	Output Enable for CLK14	
		CLK13_EN	[5]	RW	1	Output Enable for CLK13	
		CLK12_EN	[4]	RW	1	Output Enable for CLK12	
		CLK11_EN	[3]	RW	1	Output Enable for CLK11	
		CLK10_EN	[2]	RW	1	Output Enable for CLK10	
		CLK9_EN	[1]	RW	1	Output Enable for CLK9	
		CLK8_EN	[0]	RW	1	Output Enable for CLK8	
3	OEB_PIN_READBACK	RB_OEb_12	[7]	RO	1'bX	Status of OEB12	0 = pin low 1 = pin high
		RB_OEb_11	[6]	RO	1'bX	Status of OEB11	
		RB_OEb_10 <sup>[1]</sup>	[5]	RO	1'bX	Status of OEB10	
		RB_OEb_9	[4]	RO	1'bX	Status of OEB9	
		RB_OEb_8	[3]	RO	1'bX	Status of OEB8	
		RB_OEb_7	[2]	RO	1'bX	Status of OEB7	
		RB_OEb_6 <sup>[1]</sup>	[1]	RO	1'bX	Status of OEB6	
		RB_OEb_5 <sup>[1]</sup>	[0]	RO	1'bX	Status of OEB5	
4	SBEN_RDBK_ACP_CONFIG	RESERVED	[7:5]	RW	1'b111	RESERVED	-
		ACP_ENABLE	[4]	RW	1	Enable Automatic Clock Parking to low/low when LOS event is detected	0 = disable ACP 1 = enable ACP
		RESERVED	[3:1]	RW	1'b110	RESERVED	-
		RB_SBI_ENQ	[0]	RO	1'bX	Status of SBI_ENQ	0 = pin low 1 = pin high

Table 34. RC19020A072 SMBus Registers (Cont.)

Byte	Register	Name	Bit	Type	Default	Description	Definition
5	VENDOR_REVISION_ID	RID	[7:4]	RO	0x0	REVISION ID, A rev is 0000	-
		VID	[3:0]	RO	0x1	VENDOR ID, ICS/IDT/Renesas	-
6	DEVICE_ID	DEVICE_ID	[7:0]	RO	0xC8	Device ID	-
7	BYTE_COUNT	RESERVED	[7:5]	RW	0x0	RESERVED	-
		BC	[4:0]	RW	0x8	Writing to this register configures how many bytes will be read back in a block read	-
8	OEB_Configuration_A	CFGA_OEb12	[7]	RW	1	Controls CLK12	0 = OEB does not control output 1 = OEB controls output
		CFGA_OEb11	[6]	RW	1	Controls CLK11	
		CFGA_OEb10	[5]	RW	1	Controls CLK10 when SBI_ENQ = 0	
		CFGA_OEb9	[4]	RW	1	Controls CLK9	
		CFGA_OEb8	[3]	RW	1	Controls CLK8	
		CFGA_OEb7	[2]	RW	1	Controls CLK7	
		CFGA_OEb6	[1]	RW	1	Controls CLK6 when SBI_ENQ = 0	
9	OEB_Configuration_B	CFGB_OEb12	[7]	RW	0	Controls CLK13	0 = OEB does not control output 1 = OEB controls output
		CFGB_OEb11	[6]	RW	0	Controls CLK14	
		CFGB_OEb10	[5]	RW	0	Controls CLK15 when SBI_ENQ = 0	
		CFGB_OEb9	[4]	RW	0	Controls CLK0	
		CFGB_OEb8	[3]	RW	0	Controls CLK1	
		CFGB_OEb7	[2]	RW	0	Controls CLK2	
		CFGB_OEb6	[1]	RW	0	Controls CLK3 when SBI_ENQ = 0	
10	OEB_Configuration_C_AMP_Control_	CFGC_OEb12	[7]	RW	0	Controls CLK16	0 = OEB does not control output 1 = OEB controls output
		CFGC_OEb11	[6]	RW	0	Controls CLK17	
		CFGC_OEb10	[5]	RW	0	Controls CLK18 when SBI_EN = 0	
		CFGC_OEb9	[4]	RW	0	Controls CLK19	
		AMPLITUDE_CTRL	[3:0]	RW	0x7	Global Differential output Control 0.6V~1V 25mV/step Default = 0.8V	-

Table 34. RC19020A072 SMBus Registers (Cont.)

Byte	Register	Name	Bit	Type	Default	Description	Definition
11	OUTPUT_SLEW_RATE_0	CLK7_SLEWRATE	[7]	RW	1	CLK7 Slewrate Control	0 = low slew rate 1 = high slew rate
		CLK6_SLEWRATE	[6]	RW	1	CLK6 Slewrate Control	
		CLK5_SLEWRATE	[5]	RW	1	CLK5 Slewrate Control	
		CLK4_SLEWRATE	[4]	RW	1	CLK4 Slewrate Control	
		CLK3_SLEWRATE	[3]	RW	1	CLK3 Slewrate Control	
		CLK2_SLEWRATE	[2]	RW	1	CLK2 Slewrate Control	
		CLK1_SLEWRATE	[1]	RW	1	CLK1 Slewrate Control	
		CLK0_SLEWRATE	[0]	RW	1	CLK0 Slewrate Control	
12	OUTPUT_SLEW_RATE_1	CLK15_SLEWRATE	[7]	RW	1	CLK15 Slewrate Control	0 = low slew rate 1 = high slew rate
		CLK14_SLEWRATE	[6]	RW	1	CLK14 Slewrate Control	
		CLK13_SLEWRATE	[5]	RW	1	CLK13 Slewrate Control	
		CLK12_SLEWRATE	[4]	RW	1	CLK12 Slewrate Control	
		CLK11_SLEWRATE	[3]	RW	1	CLK11 Slewrate Control	
		CLK10_SLEWRATE	[2]	RW	1	CLK10 Slewrate Control	
		CLK9_SLEWRATE	[1]	RW	1	CLK9 Slewrate Control	
		CLK8_SLEWRATE	[0]	RW	1	CLK8 Slewrate Control	
13	OUTPUT_SLEW_RATE_2	RESERVED	[7:4]	RW	0b111	RESERVED	0 = low slew rate 1 = high slew rate
		CLK19_SLEWRATE	[3]	RW	1	CLK19 Slewrate Control	
		CLK18_SLEWRATE	[2]	RW	1	CLK18 Slewrate Control	
		CLK17_SLEWRATE	[1]	RW	1	CLK17 Slewrate Control	
		CLK16_SLEWRATE	[0]	RW	1	CLK16 Slewrate Control	
14 - 20	RESERVED	-	-	-	-	RESERVED	-



Table 34. RC19020A072 SMBus Registers (Cont.)

Byte	Register	Name	Bit	Type	Default	Description	Definition
21	PD_RESTORE_LOSb	AC_IN	[7]	RW	0	Enable receiver bias when CLKIN is AC coupled,	0 = DC coupled input 1 = AC coupled input
		Rx_TERM	[6]	RW	0	Enable termination resistors on CLKIN	0 = input termination R is disabled 1 = input termination R is enabled
		RESERVED	[5]	RW	1'b1	RESERVED	-
		CLK Acquired	[4]	RO	1'bX	A clock was acquired	1 = clock acquired
		PD_RESTOREb	[3]	RW	1	Save Configuration in Power Down	0 = Config Cleared 1 = Config Saved
		SDATA_TIMEOUT_EN	[2]	RW	1	Enable SMB SDATA time out monitoring	0 = disable SDATA time out 1 = enable SDATA time out
		RESERVED	[1]	RO	1'bX	-	-
		LOSb_RB	[0]	RO	1'bX	Real time read back of loss detect block output	0 = LOS event detected 1 = NO LOS event detected.
22	SBI_MASK_0 [2]	MASK7	[7]	RW	0	Masks off Side-band Disable for CLK7	0 = SBI may disable the output 1 = SBI cannot disable the output
		MASK6	[6]	RW	0	Masks off Side-band Disable for CLK6	
		MASK5	[5]	RW	0	Masks off Side-band Disable for CLK5	
		MASK4	[4]	RW	0	Masks off Side-band Disable for CLK4	
		MASK3	[3]	RW	0	Masks off Side-band Disable for CLK3	
		MASK2	[2]	RW	0	Masks off Side-band Disable for CLK2	
		MASK1	[1]	RW	0	Masks off Side-band Disable for CLK1	
		MASK0	[0]	RW	0	Masks off Side-band Disable for CLK0	

Table 34. RC19020A072 SMBus Registers (Cont.)

Byte	Register	Name	Bit	Type	Default	Description	Definition
23	SBI_MASK_1 [2]	MASK15	[7]	RW	0	Masks off Side-band Disable for CLK15	0 = SBI may disable the output 1 = SBI cannot disable the output
		MASK14	[6]	RW	0	Masks off Side-band Disable for CLK14	
		MASK13	[5]	RW	0	Masks off Side-band Disable for CLK13	
		MASK12	[4]	RW	0	Masks off Side-band Disable for CLK12	
		MASK11	[3]	RW	0	Masks off Side-band Disable for CLK11	
		MASK10	[2]	RW	0	Masks off Side-band Disable for CLK10	
		MASK9	[1]	RW	0	Masks off Side-band Disable for CLK9	
		MASK8	[0]	RW	0	Masks off Side-band Disable for CLK8	
24	SBI_MASK_2 [2]	MASK23	[7]	RW	0	Masks off Side-band Disable for CLK23	0 = SBI may disable the output 1 = SBI cannot disable the output
		MASK22	[6]	RW	0	Masks off Side-band Disable for CLK22	
		MASK21	[5]	RW	0	Masks off Side-band Disable for CLK21	
		MASK20	[4]	RW	0	Masks off Side-band Disable for CLK20	
		MASK19	[3]	RW	0	Masks off Side-band Disable for CLK19	
		MASK18	[2]	RW	0	Masks off Side-band Disable for CLK18	
		MASK17	[1]	RW	0	Masks off Side-band Disable for CLK17	
		MASK16	[0]	RW	0	Masks off Side-band Disable for CLK16	
25–32	RESERVED	RESERVED	[7:0]	RW	0xXX	RESERVED	-

Table 34. RC19020A072 SMBus Registers (Cont.)

Byte	Register	Name	Bit	Type	Default	Description	Definition
33	SBI_READBACK_0 [2]	SBI_CLK7	[7]	RO	1'bX	Readback of Side-band Disable for CLK7	0 = bit low 1 = bit high
		SBI_CLK6	[6]	RO	1'bX	Readback of Side-band Disable for CLK6	
		SBI_CLK5	[5]	RO	1'bX	Readback of Side-band Disable for CLK5	
		SBI_CLK4	[4]	RO	1'bX	Readback of Side-band Disable for CLK4	
		SBI_CLK3	[3]	RO	1'bX	Readback of Side-band Disable for CLK3	
		SBI_CLK2	[2]	RO	1'bX	Readback of Side-band Disable for CLK2	
		SBI_CLK1	[1]	RO	1'bX	Readback of Side-band Disable for CLK1	
		SBI_CLK0	[0]	RO	1'bX	Readback of Side-band Disable for CLK0	
34	SBI_READBACK_1 [2]	SBI_CLK15	[7]	RO	1'bX	Readback of Side-band Disable for CLK15	0 = bit low 1 = bit high
		SBI_CLK14	[6]	RO	1'bX	Readback of Side-band Disable for CLK14	
		SBI_CLK13	[5]	RO	1'bX	Readback of Side-band Disable for CLK13	
		SBI_CLK12	[4]	RO	1'bX	Readback of Side-band Disable for CLK12	
		SBI_CLK11	[3]	RO	1'bX	Readback of Side-band Disable for CLK11	
		SBI_CLK10	[2]	RO	1'bX	Readback of Side-band Disable for CLK10	
		SBI_CLK9	[1]	RO	1'bX	Readback of Side-band Disable for CLK9	
		SBI_CLK8	[0]	RO	1'bX	Readback of Side-band Disable for CLK8	
35	SBI_READBACK_2 [2]	RESERVED	[7:4]	RO	1'bXXX	RESERVED	0 = bit low 1 = bit high
		SBI_CLK19	[3]	RO	1'bX	Readback of Side-band Disable for CLK19	
		SBI_CLK18	[2]	RO	1'bX	Readback of Side-band Disable for CLK18	
		SBI_CLK17	[1]	RO	1'bX	Readback of Side-band Disable for CLK17	
		SBI_CLK16	[0]	RO	1'bX	Readback of Side-band Disable for CLK16	
36-37	RESERVED	RESERVED	[7:0]	RW	0xXX	RESERVED	RESERVED

Table 34. RC19020A072 SMBus Registers (Cont.)

Byte	Register	Name	Bit	Type	Default	Description	Definition
38	WRITE_LOCK_NCLEAR	RESERVED	[7:1]	RW	0x0	RESERVED	-
		WRITE_LOCK	[0]	RW	0	Non-clearable SMBus Write Lock bit. Once written to '1', the SMBus control registers cannot be written to. This bit can only be cleared by cycling power.	0 = SMBus not locked for writing by this bit. See WRITE_LOCK_RW1C bit. 1 = SMBus locked for writing
39	WRITE_LOCK_CLEAR_LOS_EVENT	RESERVED	[7:2]	RW1C	1'b111000	-	-
		LOS_EVT	[1]	RW1C	0	LOS Event Status When high, indicates that a LOS event was detected. Can be cleared by writing a 1 to it.	0 = No LOS event detected 1 = LOS event detected.
		WRITE_LOCK_RW1C	[0]	RW1C	0	Clearable SMBus Write Lock bit. When written to one, other SMBus control registers cannot be written to. This bit can be cleared by writing a 1 to it.	0 = SMBus not locked for writing by this bit. See WRITE_LOCK bit. 1 = SMBus locked for writing

1. Register is only valid when the Side-Band Interface is not enabled (SBI\_ENQ = 0).
2. Register only valid when the Side-Band Interface is enabled (SBI\_ENQ = 1).

## 4.9 RC1901xA/RC1900xA SMBus Registers

Table 35. RC1901xA/RC1900xA SMBus Registers

Byte	Register	Bit	Name	Type	Default	Description	Definition
0	OUTPUT_ENABLE_0	[7]	CLK7_EN	RW	1	Output Enable Bit for CLK7	0 = output is disabled (low/low) 1 = output is enabled
		[6]	CLK6_EN	RW	1	Output Enable Bit for CLK6	
		[5]	CLK5_EN	RW	1	Output Enable Bit for CLK5	
		[4]	CLK4_EN	RW	1	Output Enable Bit for CLK4	
		[3]	CLK3_EN	RW	1	Output Enable Bit for CLK3	
		[2]	CLK2_EN	RW	1	Output Enable Bit for CLK2	
		[1]	CLK1_EN	RW	1	Output Enable Bit for CLK1	
[0]	CLK0_EN	RW	1	Output Enable Bit for CLK0			

Table 35. RC1901xA/RC1900xA SMBus Registers (Cont.)

Byte	Register	Bit	Name	Type	Default	Description	Definition
1	OUTPUT_ENABLE_1	[7]	CLK15_EN	RW	1	Output Enable Bit for CLK15	0 = output is disabled (low/low) 1 = output is enabled
		[6]	CLK14_EN	RW	1	Output Enable Bit for CLK14	
		[5]	CLK13_EN	RW	1	Output Enable Bit for CLK13	
		[4]	CLK12_EN	RW	1	Output Enable Bit for CLK12	
		[3]	CLK11_EN	RW	1	Output Enable Bit for CLK11	
		[2]	CLK10_EN	RW	1	Output Enable Bit for CLK10	
		[1]	CLK9_EN	RW	1	Output Enable Bit for CLK9	
2	OEB_PIN_READBACK_0	[7]	OE7b_Readback	RO	pin	Status of OE7b pin	0 = OEB pin low 1 = OEB Pin high
		[6]	OE6b_Readback	RO	pin	Status of OE6b pin	
		[5]	OE5b_Readback	RO	pin	Status of OE5b pin	
		[4]	OE4b_Readback	RO	pin	Status of OE4b pin	
		[3]	OE3b_Readback	RO	pin	Status of OE3b pin	
		[2]	OE2b_Readback	RO	pin	Status of OE2b pin	
		[1]	OE1b_Readback	RO	pin	Status of OE1b pin	
3	OEB_PIN_READBACK_1	[7]	OE15b_Readback	RO	pin	Status of OE15b pin	0 = OEB pin low 1 = OEB Pin high
		[6]	OE14b_Readback	RO	pin	Status of OE14b pin	
		[5]	OE13b_Readback	RO	pin	Status of OE13b pin	
		[4]	OE12b_Readback	RO	pin	Status of OE12b pin	
		[3]	OE11b_Readback	RO	pin	Status of OE11b pin	
		[2]	OE10b_Readback	RO	pin	Status of OE10b pin	
		[1]	OE9b_Readback	RO	pin	Status of OE9b pin	
4	SBEN_RDBK_LOS_CONFIG	[7:5]	RESERVED	-	-	-	-
		[4]	LOSb_ACP_ENABLE	RW	1	Enable input loss detect to park outputs low/low	0 = disable, 1 = enable
		[3:2]	RESERVED	-	-	-	-
		[1]	RESERVED	-	-	-	-
		[0]	RB_SBI_EN	RO	pin	Status of SBI_EN	0 = pin low 1 = pin high
5	VENDOR_REVISION_ID	[7:4]	RID	RO	0x0	REVISION ID, A rev is 0000	-
		[3:0]	VID	RO	0x1	VENDOR ID, ICS/IDT/Renesas	-

Table 35. RC1901xA/RC1900xA SMBus Registers (Cont.)

Byte	Register	Bit	Name	Type	Default	Description	Definition
6	DEVICE_ID	[7:0]	DEVICE_ID	RO	0x18	Device ID: RC19016A = 0h10, RC19013A = 0h0D, RC19008A = 0h08, RC19004A = 0h04, RC19016A100 = 0h90, RC19013A100 = 0h8D, RC19008A100 = 0h88, RC19004A100 = 0h84	-
7	BYTE_COUNT	[7:5]	RESERVED	-	-	-	-
		[4:0]	BC	RW	0x7	Writing to this register configures how many bytes will be read back in a block read.	-
8	SBI_MASK_0 (Register only functional and/or valid when SBEN = 1)	[7]	MASK7	RW	0	Masks off Side-band Disable for CLK7	0 = SBI may disable the output 1 = SBI cannot disable the output
		[6]	MASK6	RW	0	Masks off Side-band Disable for CLK6	
		[5]	MASK5	RW	0	Masks off Side-band Disable for CLK5	
		[4]	MASK4	RW	0	Masks off Side-band Disable for CLK4	
		[3]	MASK3	RW	0	Masks off Side-band Disable for CLK3	
		[2]	MASK2	RW	0	Masks off Side-band Disable for CLK2	
		[1]	MASK1	RW	0	Masks off Side-band Disable for CLK1	
		[0]	MASK0	RW	0	Masks off Side-band Disable for CLK0	
9	SBI_MASK_1 (Register only functional and/or valid when SBEN = 1)	[7]	MASK15	RW	0	Masks off Side-band Disable for CLK15	0 = SBI may disable the output 1 = SBI cannot disable the output
		[6]	MASK14	RW	0	Masks off Side-band Disable for CLK14	
		[5]	MASK13	RW	0	Masks off Side-band Disable for CLK13	
		[4]	MASK12	RW	0	Masks off Side-band Disable for CLK12	
		[3]	MASK11	RW	0	Masks off Side-band Disable for CLK11	
		[2]	MASK10	RW	0	Masks off Side-band Disable for CLK10	
		[1]	MASK9	RW	0	Masks off Side-band Disable for CLK9	
		[0]	MASK8	RW	0	Masks off Side-band Disable for CLK8	
10	RESERVED	[7:0]	Reserved	-	-	-	-

Table 35. RC1901xA/RC1900xA SMBus Registers (Cont.)

Byte	Register	Bit	Name	Type	Default	Description	Definition
11	SBI_READBACK_0 (Register only functional and/or valid when SBEN = 1)	[7]	SBI_CLK7	RO	X	Readback of Side-band Disable for CLK7	0 = bit low 1 = bit high
		[6]	SBI_CLK6	RO	X	Readback of Side-band Disable for CLK6	
		[5]	SBI_CLK5	RO	X	Readback of Side-band Disable for CLK5	
		[4]	SBI_CLK4	RO	X	Readback of Side-band Disable for CLK4	
		[3]	SBI_CLK3	RO	X	Readback of Side-band Disable for CLK3	
		[2]	SBI_CLK2	RO	X	Readback of Side-band Disable for CLK2	
		[1]	SBI_CLK1	RO	X	Readback of Side-band Disable for CLK1	
		[0]	SBI_CLK0	RO	X	Readback of Side-band Disable for CLK0	
12	SBI_READBACK_1 (Register only functional and/or valid when SBEN = 1)	[7]	SBI_CLK15	RO	X	Readback of Side-band Disable for CLK15	0 = bit low 1 = bit high
		[6]	SBI_CLK14	RO	X	Readback of Side-band Disable for CLK14	
		[5]	SBI_CLK13	RO	X	Readback of Side-band Disable for CLK13	
		[4]	SBI_CLK12	RO	X	Readback of Side-band Disable for CLK12	
		[3]	SBI_CLK11	RO	X	Readback of Side-band Disable for CLK11	
		[2]	SBI_CLK10	RO	X	Readback of Side-band Disable for CLK10	
		[1]	SBI_CLK9	RO	X	Readback of Side-band Disable for CLK9	
		[0]	SBI_CLK8	RO	X	Readback of Side-band Disable for CLK8	
13–16	RESERVED	[7:0]	Reserved	-	-	-	-
17	LPHCSL_AMP_CTRL	[7:4]	Global Amplitude Control	RW	0x7	0.6V~1V in 25mV steps.	Default = 0.8V
		[3:0]	Reserved	-	-	-	-

Table 35. RC1901xA/RC1900xA SMBus Registers (Cont.)

Byte	Register	Bit	Name	Type	Default	Description	Definition
18	PD_RESTORE_LOSb_ENABLE	[7]	AC_IN	RW	0	Enable receiver self bias when input clock is AC coupled,	0 = DC coupled input 1 = AC coupled input
		[6]	Rx_TERM	RW	0	Enable termination resistor on CLKIN/CLKINb	0 = input termination is disabled 1 =input termination is enabled
		[5:4]	Reserved	-	-	-	-
		[3]	PD_RESTOREb	RW	1	Save Configuration in Power Down	0 = Config Cleared 1 = Config Saved
		[2:1]	Reserved	-	-	-	-
		[0]	LOSb_Readback	RO	X	real time read back of loss detect block output	0 = LOS event detected 1 = NO LOS event detected.
19	RESERVED	[7:0]	Reserved	-	-	-	-
23–37	Reserved	[7:0]	Reserved	-	-	-	-
38	WRITE_LOCK_NOCLEAR	[7:1]	Reserved	RW	0	reserved	-
		[0]	WRITE_LOCK	RW	0	Non-clearable SMBus Write Lock bit. When written to one, the SMBus control registers cannot be written to. This bit can only be cleared by cycling power.	0 = SMBus not locked for writing by this bit. See WRITE_LOCK_RW1C bit. 1 = SMBus locked for writing
39	WRITE_LOCK_CLEAR_LOS_EVENT	[7:2]	Reserved	-	-	-	-
		[1]	LOS_EVT	R/W 1C	0	LOS Event Status When high, indicates that a LOS event was detected. Can be cleared by writing a 1 to it.	0 = No LOS event detected 1 = LOS event detected.
		[0]	WRITE_LOCK_RW1C	R/W 1C	0	Clearable SMBus Write Lock bit. When written to one, the SMBus control registers cannot be written to. This bit can be cleared by writing a 1 to it.	0 = SMBus not locked for writing by this bit. See WRITE_LOCK bit. 1 = SMBus locked for writing



## 5. Applications Information

### 5.1 Inputs, Outputs, and Output Enable Control

#### 5.1.1 Recommendations for Unused Inputs and Outputs

##### 5.1.1.1 Unused Differential CLKIN Inputs

The CLKIN/CLKINb inputs of the RC19xxx devices have internal bias networks that protect the devices from a floating input clock condition. For RC192xx multiplexers that use only one input clock, the unused input can be left open. Renesas recommends that no trace be attached to unused CLKIN pins.

##### 5.1.1.2 Unused Single-ended Control Inputs

The single-ended control pins have internal pull-up and/or internal pull-down resistors and do not require external resistors. They can be left floating if the default pin state is the desired state. If external resistors are needed to change the pin state or are desired for design robustness, 10kohm is the recommended value.

##### 5.1.1.3 Unused Differential CLK Outputs

All unused CLK outputs can be left floating. Renesas recommends that no trace be attached to unused CLK outputs. While not required (but is highly recommended), the best design practice is to disable unused CLK outputs.

##### 5.1.1.4 Unused SMBus Clock and Data Pins

If the SMBus interface is not used, the clock and data pins must be pulled high with an external resistor. The two pins can share a resistor if there is no possibility of using the SMBus interface for debug purposes. If the interface may be used for debug, separate resistors should be used. 10kohm is the recommended value.

#### 5.1.2 Differential CLKIN Configurations

The RC19xxx clock input buffer supports four configurations:

- Direct connection to HCSL-level inputs
- Direct connection to LVDS-level inputs with *external* termination resistor
- Internal self-bias circuit for applications that *externally* AC-couple the input clock
  - This feature is enabled by the **AC\_IN** bit.
- Internal pull-down resistors (Rp) to terminate the clock input at the receiver.
  - This feature is enabled by the **Rx\_TERM** bit.

Devices with multiple input clocks have individual AC\_IN and Rx\_TERM configuration bits for each input. The internal input clock terminations prevent reflections and are useful for non-PCIe applications, where the frequency and transmission line length vary from the 100MHz PCIe standard.

Figure 15 through Figure 18 illustrate the above items.

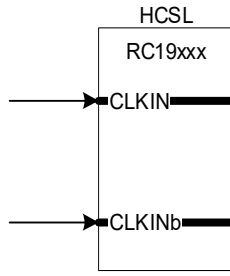

Figure 15. HCSL Input Levels (PCIe Standard)

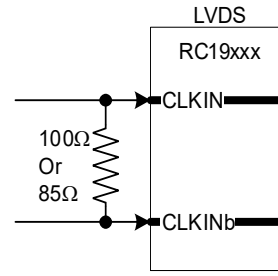

Figure 16. LVDS Input Levels

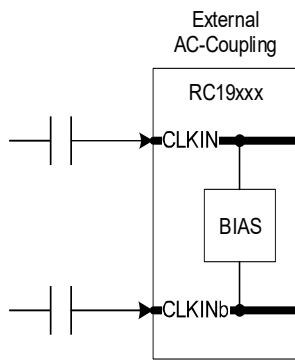

Figure 17. External AC-Coupling

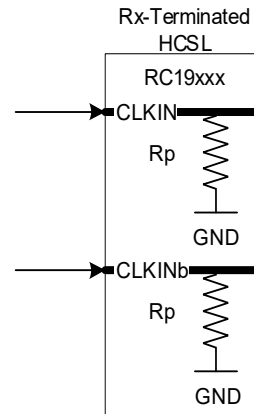

Figure 18. Receiver Termination

### 5.1.3 Differential CLK Output Configurations

#### 5.1.3.1 Direct-Coupled HCSL Loads

The RC19xxx LP-HCSL CLK outputs have internal source terminations and directly drive industry-standard HCSL-level inputs with no external components. They support both 85ohm and 100ohm differential impedances. The CLK outputs can also drive receiver-terminated HCSL loads. The combination of source termination and receiver termination results in a double-terminated load. When double-terminated, the CLK output swing will be half of the source-terminated values.

#### 5.1.3.2 AC-Coupled non-HCSL Loads

The RC19xxx CLK output can directly drive AC-coupling capacitors without any termination components. The clock input side of the AC-coupling capacitor may require an input-dependent bias network (BN). For examples of terminating the RC19xxx CLK outputs to other logic families such as LVDS, LVPECL, or CML, see [AN-891](#).

Figure 19 to Figure 21 show the various CLK output configurations.

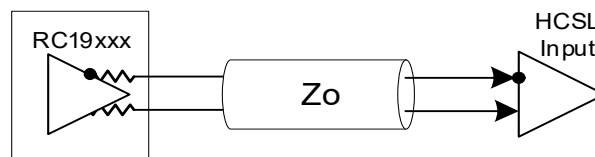

Figure 19. Direct-Coupled Source-Terminated HCSL

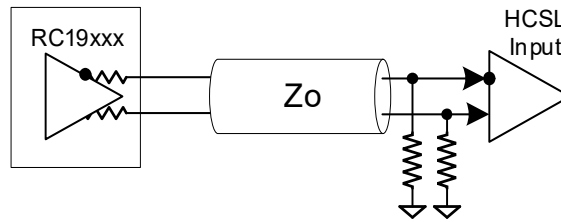

Figure 20. Direct-Coupled Double-Terminated HCSL

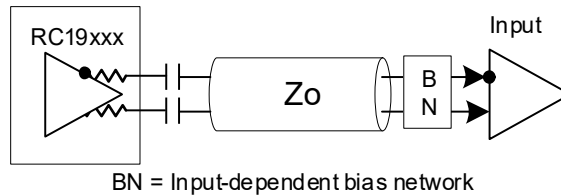

Figure 21. AC-Coupled

## 5.2 Power Down Tolerant Pins

Pins that are Power Down Tolerant (PDT) can be driven by voltages as high as the normal VDD of the chip, even though VDD is not present (the device is not powered). There will be no ill effects to the device and it will power up normally. This feature supports disaggregation, where the RC19xxx may be on one circuit board and devices that interface with it are on other boards. These boards may power up at different times, driving pins on the RC19xxx before it has received power. [Figure 22](#) provides an example of a PDT call-out in a data sheet.

## 5.3 Flexible Startup Sequencing

Table 1. RC19024A Pin Descripti

Pin Number	Pin Name	Pin Type	
A1	OEB23b_SBI_CLK	I, SE, PDT, PD	OE23b: Active Low input Side Band Interface clock function is this pin is Co
A2	CLK23B	O, DIF	Complementary clock o
A3	CLK23	O, DIF	True clock output.
A4	CLK_INb	I, DIF, PDT	Complementary clock in
A5	CLK_IN	I, DIF, PDT	True clock input.

Figure 22. Example: Power Down Tolerant Pin Descriptions

RC19xxx devices support Flexible Startup Sequencing (FSS). FSS allows application of CLKIN at different times in the device/system startup sequence. FSS is an additional feature that helps the system designer manage the impact of disaggregation. [Table 36](#) shows the supported sequences; that is, the RC19xxx devices can have CLKIN running before VDD is applied, and can have VDD applied and sit for extended periods with no input clock.

Table 36. Flexible Startup Sequences

VDD	PWRGD_PWRDNb	CLKIN/CLKINb
Not present	X	Running
		Floating
		Low/Low
Present	0 or 1	Running
		Floating
		Low/Low

### 5.4 Loss of Signal and Automatic Clock Parking

The RC19 buffers and multiplexers have a Loss of Signal (LOS) circuit to detect the presence or absence of an input clock. The LOS circuit drives the open-drain LOSb pin (the “b” suffix indicates “bar”, or active-low) and sets the LOS\_EVT bit in the SMBus register space. There are two slightly different LOSb pin behaviors at power up. Figure 23 shows the LOSb de-assertion timing for the 4, 8, 13, 16 and 24-output buffers. CLKIN is represented differentially in Figure 23 and Figure 24.

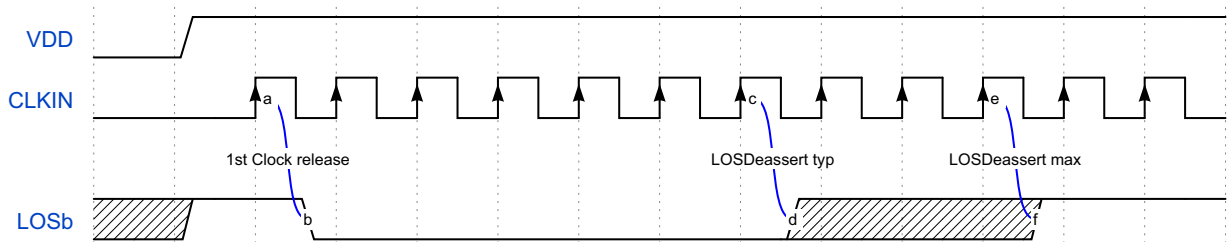

Figure 23. LOSb De-assert Timing, RC1900x, RC1901x, RC19024

Note: The LOS circuit on the 4, 8, 13, 16 and 24 output buffers requires a CLKIN edge to release the LOSb pin after power up. So, the LOSb pin will be high until the first clock edge after power up.

Figure 24 shows the LOSb de-assertion timing for the 20-output buffers and all RC192xx clock multiplexers. LOSb on the 20-output buffers and all RC192xx multiplexers defaults to low at power up.

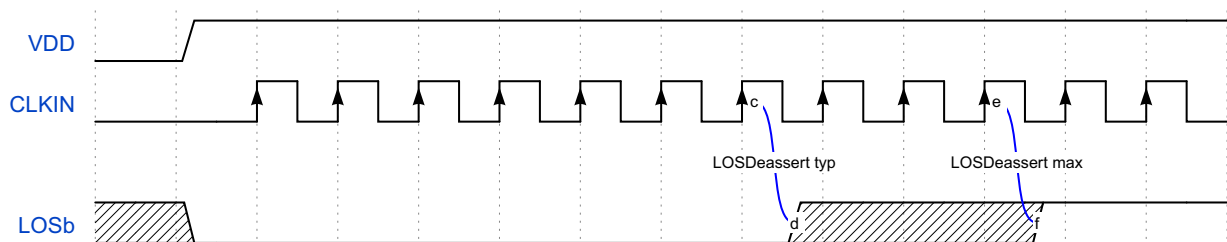

Figure 24. LOSb De-assert Timing RC19020, RC192xx Devices

Note: The LOSb pin monitors the selected input clock in the RC192xx multiplexers.

The following diagram shows the LOSb assertion sequence when the CLKIN is lost. It also shows the Automatic Clock Parking (ACP) circuit bring the inputs to a Low/Low state after an LOS event. For exact timing, see Electrical Characteristics.

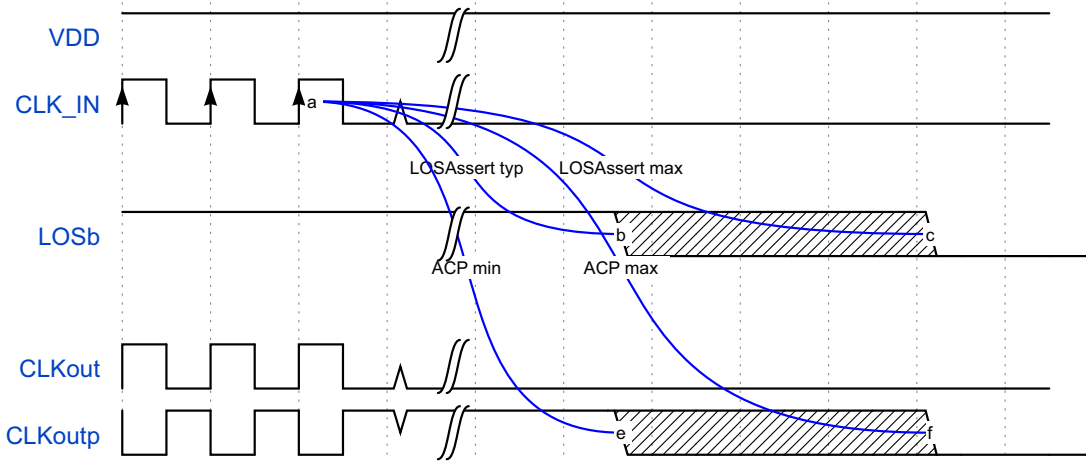

Figure 25. LOSb Assert Timing

## 5.5 Output Enable Control

The RC19xxx buffer/mux family provides three mechanisms to enable or disable clock outputs. All three mechanisms start and stop the output clocks in a synchronous, glitch-free manner. A clock output is enabled only when all three mechanisms indicate “enabled.” The following sections describe the three mechanisms.

### 5.5.1 SMBus Output Enable Bits

The RC19xxx Clock buffer/multiplexer family has a traditional SMBus output enable bit for each output. The power-up default is 1, or enabled. Changing this bit to a 0 disables the output to a low/low state. The transitions between the enable and disable states are glitch-free in both directions.

*Note:* The glitch-free synchronization logic requires the CLKIN be running to enable or disable the outputs with this mechanism.

### 5.5.2 Output Enable (OEb) Pins

The OEb (Note: the “b” suffix indicates “bar”, or active-low) pins on the RC19xxx family provide flexible CLKREQb functionality for PCIe slots and/or banked OE control for ‘motherboard-down’ devices (depending on the device). If the OEb pin is low the controlled output is enabled. If the OEb pin is high, the controlled output is disabled to a low/low state. All OEb pins enable and disable the controlled outputs in a glitch-free, synchronous manner.

*Note:* The glitch-free synchronization logic requires the CLKIN be running to enable or disable the outputs with this mechanism.

### 5.5.3 RC1902x Clock Buffer OEb Pins

The 24-output RC19024A has three dedicated OEb pins (OE2b, OE22b, and OE23b) that control CLK [2,22,23], respectively. It also has four bank OEb pins, OEb[A:D], that are mappable. Each pin can control up to six clock outputs, and defaults to controlling one output. The RC19024A output enable mapping is described in [Table 37](#).

Table 37. RC19024A OEb Mapping

Pin Name	SBI_ENQ Pin	Default Pin Function	Optional Pin Function [1]
OEb_A	X	CLK5 OEb	CLK[4:0] OEb
OEb_B	X	CLK6 OEb	CLK[11:7] OEb
OEb_C	X	CLK17 OEb	CLK[18:12] OEb
OEb_D	X	CLK18 OEb	CLK[23-19]

Table 37. RC19024A OEB Mapping (Cont.)

Pin Name	SBI_ENQ Pin	Default Pin Function	Optional Pin Function [1]
OEB2_SHFT_LDb	0 (Disabled)	CLK2 OEB	N/A
	1 (Enabled)	SHFT_LDb	N/A
OEB22_SBI_IN	0 (Disabled)	CLK22 OEB	N/A
	1 (Enabled)	SBI_IN	N/A
OEB23_SBI_CLK	0 (Disabled)	CLK23 OEB	N/A
	1 (Enabled)	SBI_CLK	N/A

1. See the OEB\_ASSIGNMENT registers in [Table 32](#).

The RC19020A and the RC19020A072 each have 8 OEB pins. Some of the pins are muxed with SBI functions. The RC19020A072 OEB pins may be configured to control up to 2 outputs. Details are provided in [Table 38](#) and [Table 39](#).

Table 38. RC19020A OEB Mapping

Pin Name	SBI_ENQ Pin	Pin Function
OEB12	X	CLK12 OEB
OEB11	X	CLK11 OEB
OEB10_SHFT_LDb	0 (Disabled)	CLK10 OEB
	1 (Enabled)	SHFT_LDb
OEB9	X	CLK9 OEB
OEB8	X	CLK8 OEB
OEB7	X	CLK7 OEB
OEB6_SBI_CLK	0 (Disabled)	CLK6 OEB
	1 (Enabled)	SBI_CLK
OEB5_SBI_IN	0 (Disabled)	CLK5 OEB
	1 (Enabled)	SBI_IN

Table 39. RC19020A072 OEB Mapping[1]

Pin Name	SBI_ENQ Pin	Default Pin Function	Optional Pin Function
OEB12	X	CLK12 OEB	CLK13 OEB
OEB11	X	CLK11 OEB	CLK14 OEB
OEB10_SHFT_LDb	0 (Disabled)	CLK10 OEB	CLK15 OEB
	1 (Enabled)	SHFT_LDb	N/A
OEB9	X	CLK9 OEB	CLK0 OEB
OEB8	X	CLK8 OEB	CLK1 OEB
OEB7	X	CLK7 OEB	CLK2 OEB
OEB6_SBI_CLK	0 (Disabled)	CLK6 OEB	CLK3 OEB
	1 (Enabled)	SBI_CLK	N/A

Table 39. RC19020A072 OEB Mapping<sup>[1]</sup> (Cont.)

Pin Name	SBI_ENQ Pin	Default Pin Function	Optional Pin Function
OEB5_SBI_IN	0 (Disabled)	CLK5 OEB	CLK4 OEB
	1 (Enabled)	SBI_IN	N/A

1. See the OEB\_ASSIGNMENT registers in [Table 34](#).

The smaller RC19016A, RC19013A, and RC19004A devices (16, 13, and 4 outputs respectively) provide a dedicated OEB pin for each output, and therefore do not have OEB\_ASSIGNMENT registers. Note that four OEB pins are used for the SBI interface when SBI\_ENQ = 1 (for more information, see [Table 40](#)).

Table 40. RC19016A, RC19013A, RC19008A, RC19004A Buffer OEB Mapping

Pin Name	SBI_ENQ Pin	RC19016A Pin Function	RC19013A Pin Function	RC19008A Pin Function	RC19004A Pin Function
OEB0	X	CLK0 OEB	CLK0 OEB	-	-
OEB1	X	CLK1 OEB	CLK1 OEB	CLK1 OEB	-
OEB2_SBI_OUT	0 (Disabled)	CLK2 OEB	CLK2 OEB	CLK2 OEB	CLK2 OEB
	1 (Enabled)	SBI_OUT	SBI_OUT	SBI_OUT	SBI_OUT
OEB3	X	CLK3 OEB	CLK3 OEB	CLK3 OEB	-
OEB4	X	CLK4 OEB	-	-	-
OEB5_SBI_CLK	0 (Disabled)	CLK5 OEB	-	CLK5 OEB	CLK5 OEB
	1 (Enabled)	SBI_CLK	-	SBI_CLK	SBI_CLK
OEB6	X	CLK6 OEB	-	CLK6 OEB	-
OEB6_SBI_CLK	0 (Disabled)	-	CLK6 OEB	-	-
	1 (Enabled)	-	SBI_CLK	-	-
OEB7	X	CLK7 OEB	CLK7 OEB	CLK7 OEB	-
OEB8	X	CLK8 OEB	CLK8 OEB	-	-
OEB9_SBI_IN	0 (Disabled)	CLK9 OEB	CLK9 OEB	-	CLK9 OEB
	1 (Enabled)	SBI_IN	SBI_IN	-	SBI_IN
OEB10	X	CLK10 OEB	CLK10 OEB	-	-
OEB10_SBI_IN	0 (Disabled)	-	-	CLK10 OEB	-
	1 (Enabled)	-	-	SBI_IN	-
OEB11	X	CLK11 OEB	CLK11 OEB	-	-
OEB12	X	CLK12 OEB	CLK12 OEB	-	-
OEB13_SHFT_LD <sub>b</sub>	0 (Disabled)	CLK13 OEB	CLK13 OEB	CLK13 OEB	CLK13 OEB
	1 (Enabled)	SHFT_LD <sub>b</sub>	SHFT_LD <sub>b</sub>	SHFT_LD <sub>b</sub>	SHFT_LD <sub>b</sub>
OEB14	X	CLK14 OEB	CLK14 OEB	-	-
OEB15	X	CLK15 OEB	-	-	-

### 5.5.4 Side-Band Interface (SBI)

SMBus output enable bits and OEB pins are the traditional methods for enabling and disabling clocks. The 2-wire SMBus interface can enable or disable all clock outputs in a device. This pin efficiency is its advantage. The SMBus interface's main drawback is that it is a relatively slow physical interface, whose software is one of several routines running on an often overtaxed micro-controller. OEB pins are real-time and are ideally dedicated to an individual clock output. As buffers grow in output count, dedicated OEB pins become problematic for two reasons. First, the clock buffer pin count becomes much larger than it otherwise would be, resulting in a larger package. Second, unless the OEB pins are used for CLKREQ# functionality, the number of pins that need to be controlled outgrows the GPIO pins of an FPGA or micro-controller.

A third output enable/disable mechanism, the Side-Band Interface (SBI), addresses these issues. The SBI is a simple 3-wire (4-wire if the SBI\_OUT pin is used) interface that can control all outputs across multiple devices. The SBI is only slightly less pin efficient than the SMBus, and is much more pin efficient than a dedicated OEB pins per output. It is protocol-free, hardware-oriented and runs at speeds up to 25MHz, much faster than SMBus.

Another SBI advantage is that it is active after power is applied and before PWRGD is asserted. External logic can disable specific outputs before PWRGD is asserted, and can then dynamically adjust the output run state during device operation. The SBI can make the adjustments much more rapidly than SMBus.

The RC19xxxA 4-wire SBI interface consists of the SBI\_IN, SBI\_CLK, SHFT\_LDb, and SBI\_OUT pins. The RC19xxxA SBI is enabled by strapping the SBI\_ENQ pin to 1. When enabled, various OEB pins become the SBI interface. The exact pins that are multiplexed vary with device (for more information, see [Table 40](#)).

The SBI\_ENQ pin strap takes effect as soon as power is applied and is not dependent on the assertion of PWRGD\_PWRDNb to 1. Because of this, the SBI\_ENQ must be static and cannot change once power is applied. If SBI\_ENQ is 0 when power is applied, the SBI is disabled and has no impact on enabling or disabling outputs.

The SBI consists of a shift register, an SMBus readback register (of the shift register contents), and an SMBus MASK register. The SBI shifts a bit stream containing the enable/disable pattern into the shift register. A 1 enables an output and a 0 disables an output. All shift-register bits default to 1 at power up, indicating an enabled state. This means that the SBI can be used to disable outputs at power up because the default is enabled.

The SBI has its own SBI\_CLK and does not need a running CLKIN to shift in an enable/disable pattern. This provides utmost flexibility for setting output run state before the SMBus becomes active or before the CLKIN is applied. When the SBI indicates enabled, the standard SMBus output enable bits and OEB pins can control the outputs.

The SBI feeds common output enable/disable synchronization logic ensuring glitch-free enable and disable of outputs. Note: The glitch-free synchronization logic requires the CLKIN be running to enable or disable the outputs with this mechanism.

If the application does not use the SBI, the SBI\_ENQ pin can be tied to 0, and the entire SBI has no impact on enabling or disabling clock outputs.

The SBI Mask registers allow the user to block the disable function of the SBI via the SMBus. The SBI Mask registers default to 0 at power-up, allowing the SBI shift register bits to disable their respective output. After asserting the PWRGD\_PWRDNb pin high, the SMBus is active and the SBI mask registers can be configured via SMBus to mask off (block) the SBI disable function. In other words, setting an SBI Mask bit to 1 forces the SBI to always indicate "enable" for the respective output. This allows the user to prevent the SBI from accidentally turning off a critical output.

The RC190xx clock buffers provide the ability to read back the SBI shift register contents via the SMBus. The SMBus readback values update on each falling edge of SHFT\_LDb. Note: The SBI shift register can only be read using the SMBus; the SMBus *cannot* be used to load it.

[Figure 26](#) shows the high-level functional description of SBI.



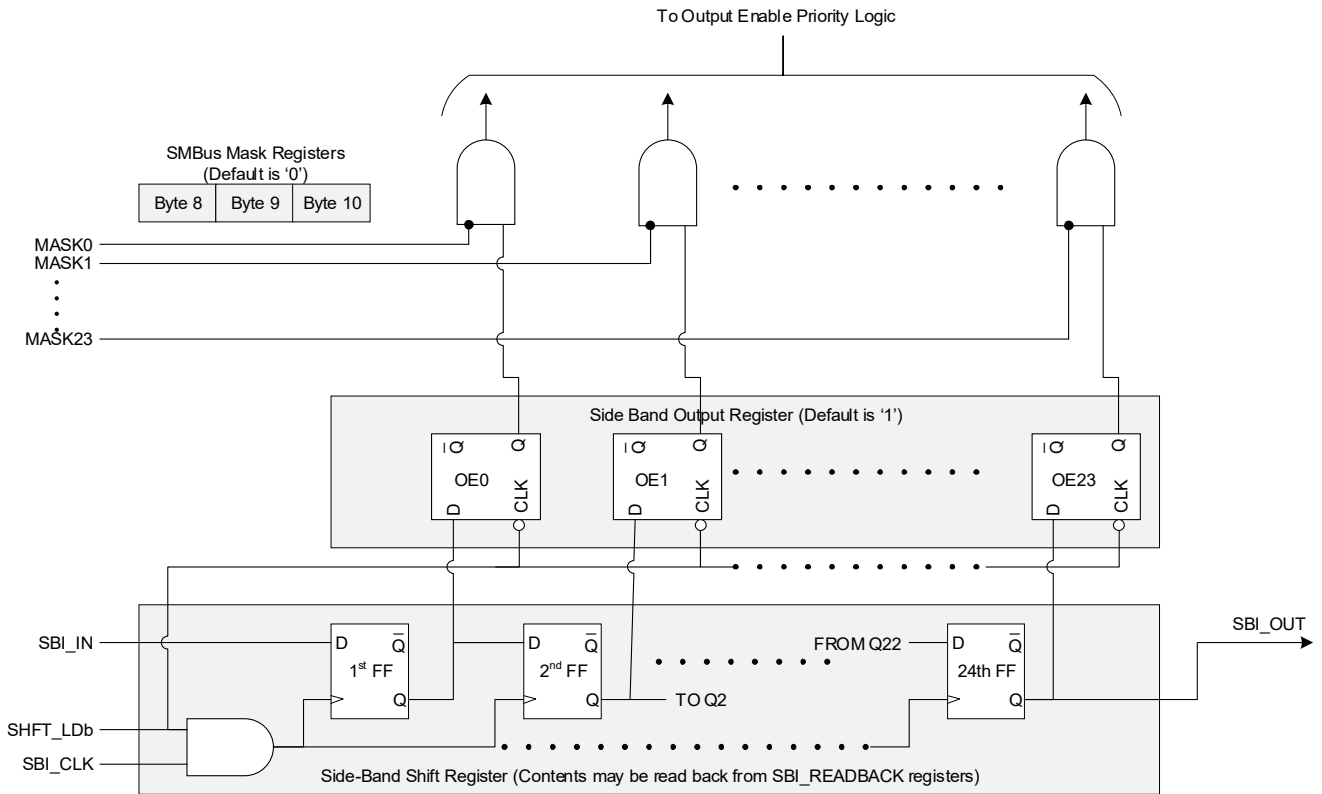

Figure 26. Side-band Interface High-Level Functional Diagram (RC19024A shown)

### 5.5.4.1 Using the SBI

Using the RC19024A as an example, we see the SBI shift order follows the order of the SMBus enable bits. in Byte [2:0] as shown in Figure 27. The first bit shifted in would be the output enable/disable bit for the CLK23, which is in Byte 2 bit 7. The last bit shifted in would be the output enable/disable for CLK0, which is in Byte 0, bit 0.

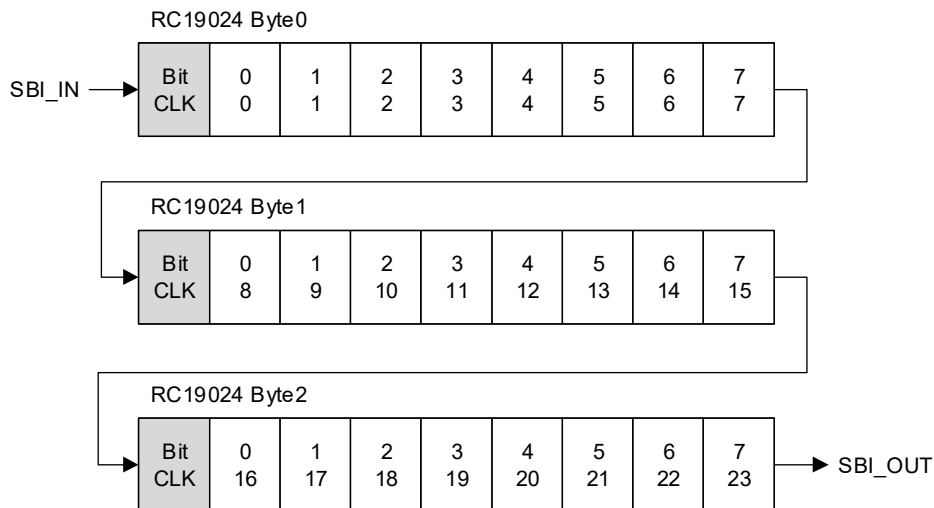

Figure 27. RC19024A Side-Band Shift Order

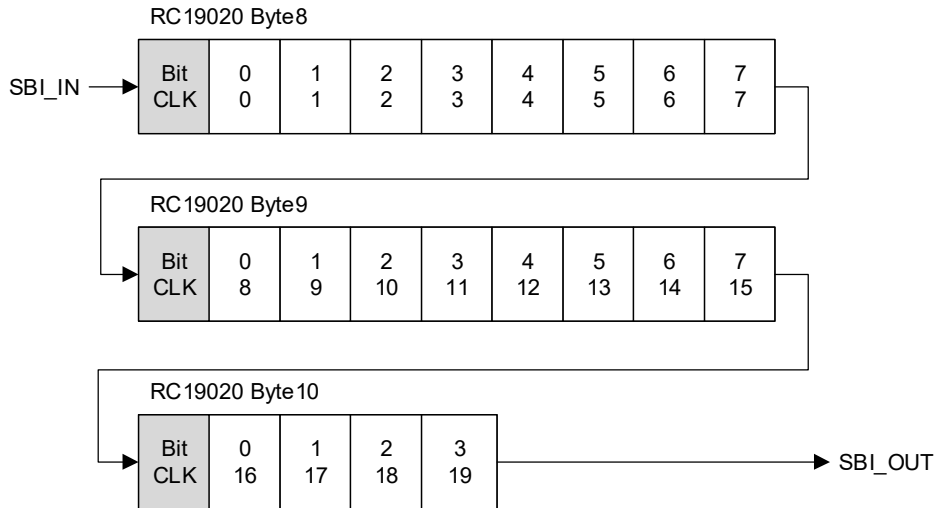

Figure 28. RC19020A Side-Band Shift Order

Figure 29 through Figure 32 show the Side-Band Shift Order for the RC19016A, RC19013A, RC19008A, and RC19004A buffers. Notice that the Side-Band Shift Count is equal to the number of outputs in each device.

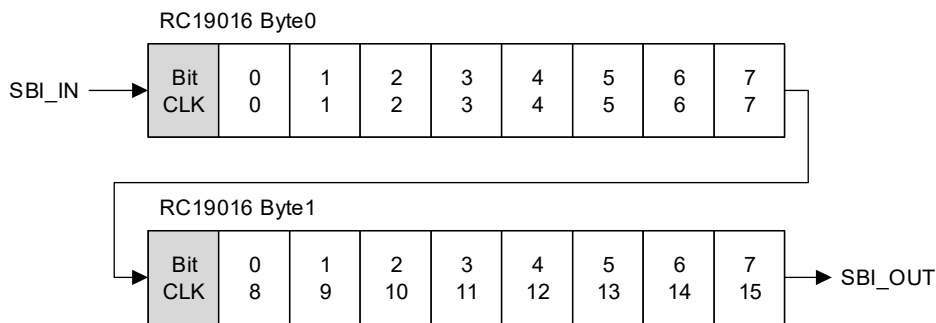

Figure 29. RC19016A Side-Band Shift Order

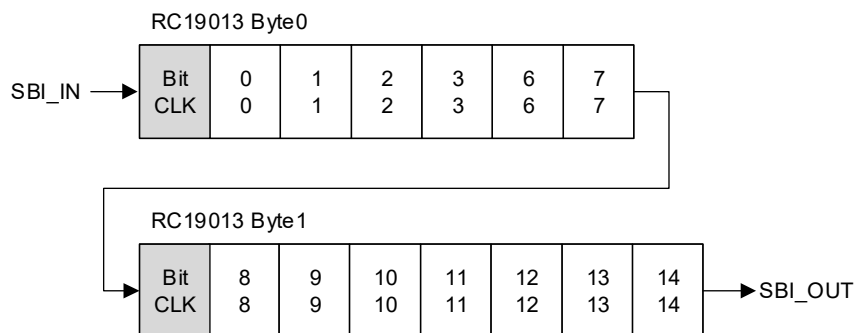

Figure 30. RC19013A Side-Band Shift Order

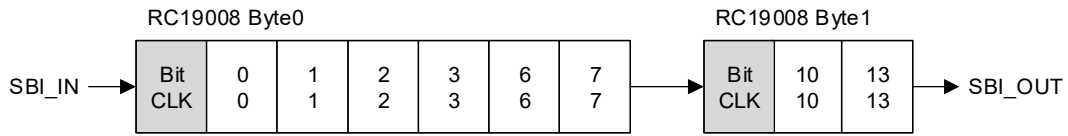

Figure 31. RC19008A Side-Band Shift Order

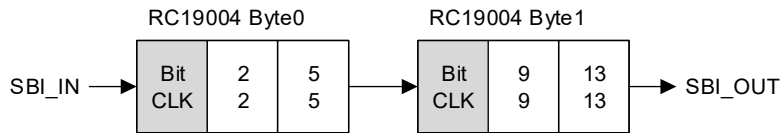

Figure 32. RC19004A Side-Band Shift Order

5.5.4.2 Side-Band Interface Timing

Figure 33 shows the basic timing of the side-band interface. The SHFT\_LDb pin goes high to enable the SBI\_CLK input. Next, the rising edge of SBI\_CLK clocks SBI\_IN data into the shift register. After the 24<sup>th</sup> clock (assuming the RC19024A), stop the SBI\_CLK low and drive the SHFT\_LDB pin low. The falling edge of SHFT\_LDb latches the shift register contents to the output control register, disabling or enabling the outputs. Always shift the complete set of bits into the shift register to control the outputs. For the Side-Band Interface AC/DC Electrical Characteristics, see Table 28.

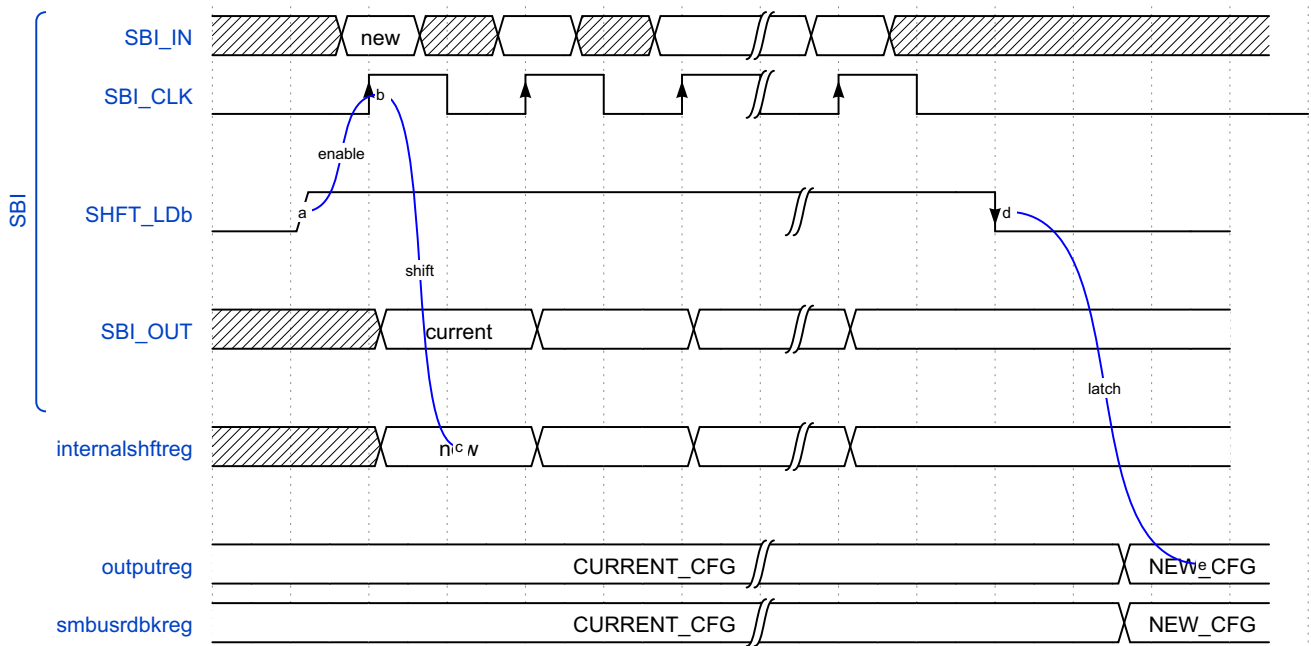

Figure 33. Side-Band Interface Functional Timing

5.5.4.3 Side-Band Interface Connection Topologies

The RC19xxxA buffer/mux devices support two SBI connection topologies: star and daisy chain. In a star topology, multiple devices can share the SBI\_CLK and SBI\_IN pins. In this topology, each RC190xx has a dedicated SHFT\_LDb pin. In a daisy-chain topology, the SBI\_OUT of one device connects to the SBI\_IN of a downstream device. When using the daisy-chain topology, the user must shift a complete set of bits for the combined devices. Two daisy-chained RC19024A devices require shifting of  $2 \times 24 = 48$  bits. An RC19016A followed by an RC19008A would require shifting  $8 + 16 = 24$  bits. When the SHFT\_LDb pin is low, the SBI interface ignores any activity on the SBI\_CLK and SBI\_IN pins.

Figure 34 shows a star topology connection for the RC19xxxA SBI interface. The star topology allows independent configuration of each device. For the RC19024A, this means shifting 24 bits at a time. A disadvantage is that a separate SHFT\_LDb pin is required for each device. The star topology allows additional devices to be controlled at the cost of an additional GPIO per device.

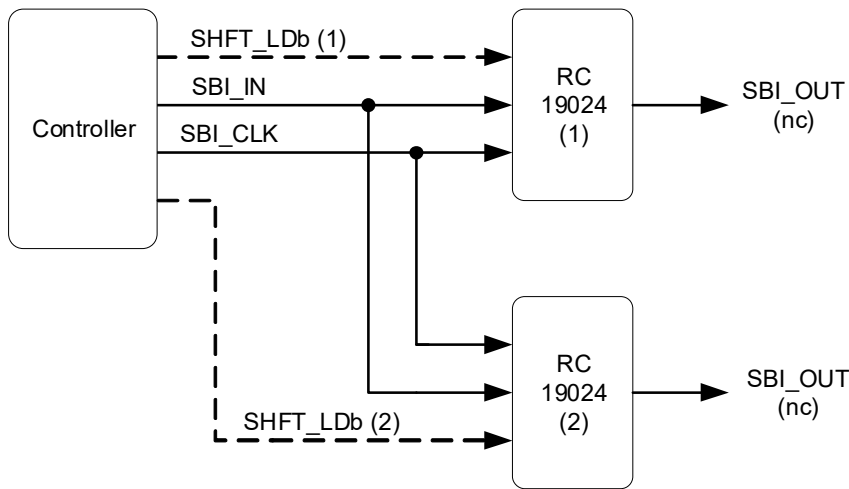

Figure 34. Side-Band Interface Star Topology

The daisy-chain topology allows configuration of any number of devices with only three signals from the SBI controller. It uses the SBI\_OUT pin of one device to drive the SBI\_IN pin of the next device in the daisy chain. Users must take care to shift the proper number of bits in this configuration. For the example shown in Figure 35, the SBI bit stream consists of 48 bits.

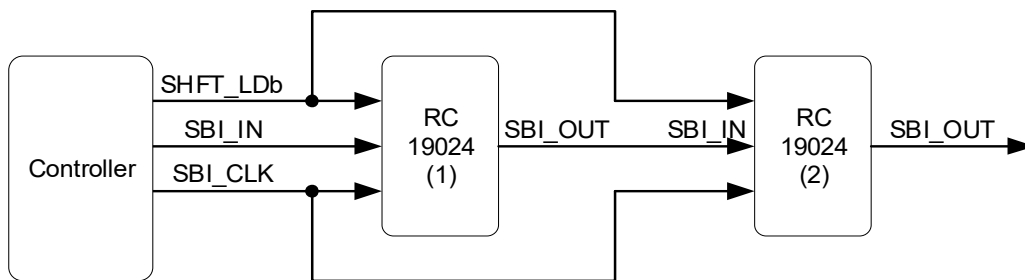

Figure 35. Side-Band Interface Daisy-Chain Topology

### 5.5.5 Output Enable/Disable Priority

The RC19xxxA output enable/disable priority is an “AND” function of all enable methods. This means that the SMBus output enable bit AND the OEB pin (if present/assigned) AND the SBI must indicate that the output is enabled in order for the output to be enabled. A logical representation of the priority logic is shown in [Figure 36](#).

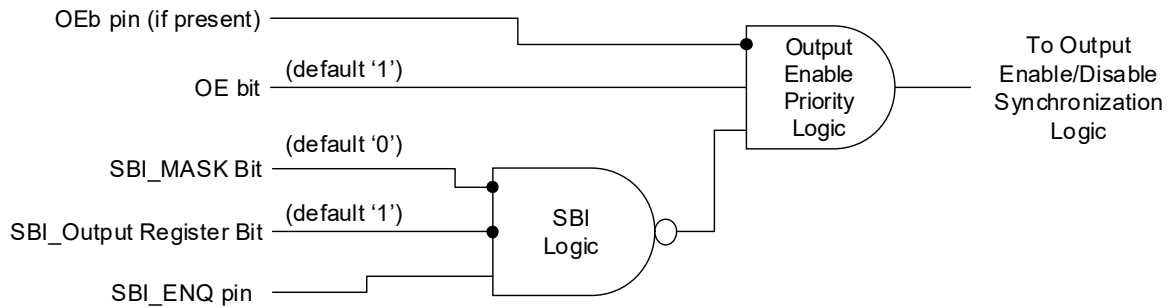

Figure 36. Output Enable/Disable Priority (Logical)

## 6. Package Outline Drawings

The package outline drawings are located at the end of this document and are accessible from the Renesas website (see the package links in [Ordering Information](#)). The package information is the most current data available and is subject to change without revision of this document.

## 7. Marking Diagrams

### 7.1 RC1901xA/RC1900xA Marking Diagrams

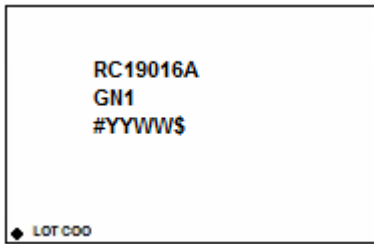

RC19016A 64-VFQFPN 85Ω

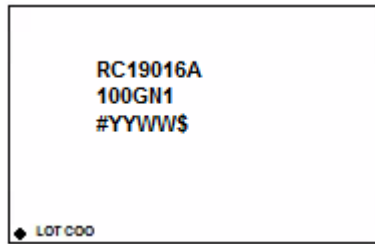

RC19016A 64-VFQFPN 100Ω

- Lines 1 and 2: part number.
- Line 3:
  - “#” indicates stepping number.
  - “YYWW” indicates the last two digits of the year and work week the part was assembled.
  - “\$” indicates the mark code.

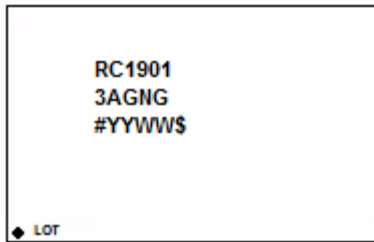

RC19013A 56-VFQFPN 85Ω

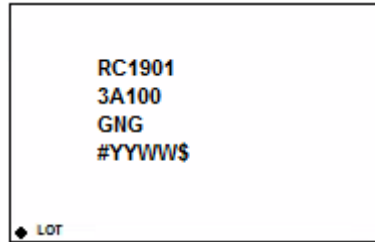

RC19013A 56-VFQFPN 100Ω

- Lines 1 and 2 (for 85Ω); 1, 2, and 3 (for 100Ω): part number.
- Line 3 (for 85Ω) or 4 (for 100Ω):
  - “#” indicates stepping number.
  - “YYWW” indicates the last two digits of the year and work week the part was assembled.
- “\$” indicates the mark code.

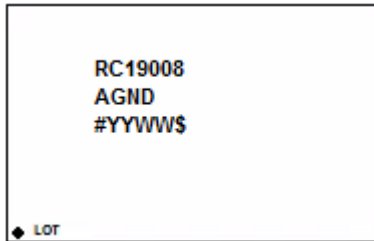

RC19008A 40-VFQFPN 85Ω

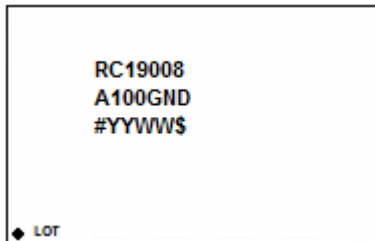

RC19008A 40-VFQFPN 100Ω

- Lines 1 and 2: part number.
- Line 3:
  - “#” indicates stepping number.
  - “YYWW” indicates the last two digits of the year and work week the part was assembled.
- “\$” indicates the mark code.



RC19004A 28-VFQFPN 85Ω

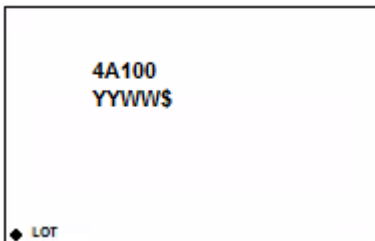

RC19004A 28-VFQFPN 100Ω

- Line 1: truncated part number.
- Line 2:
  - “YYWW” indicates the last two digits of the year and work week the part was assembled.
- “\$” indicates the mark code.

## 7.2 RC1902xA Marking Diagrams

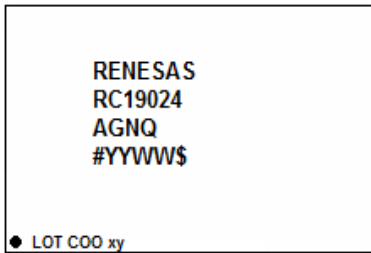

RC19024A 100-VFQFPN 85Ω

- Lines 2 and 3: part number
- Line 4:
  - “#” denotes the stepping number.
  - “YYWW” denotes the last two digits of the year and the work week the part was assembled.
  - “\$” denotes the mark code.
- “LOT” denotes the lot number
- “COO” denotes country of origin.

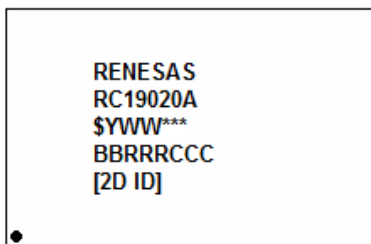

RC19020A 80-GQFN 85Ω

- Lines 2 and 3: part number
- Line 4:
  - “#” denotes the stepping number.
  - “YYWW” denotes the last two digits of the year and the work week the part was assembled.
  - “\$” denotes the mark code.
- “LOT” denotes the lot number



RC19020A072 72-VFQFPN 85Ω

- Lines 2 and 3: part number
- Line 4:
  - “#” denotes the stepping number.
  - “YYWW” denotes the last two digits of the year and the work week the part was assembled.
  - “\$” denotes the mark code.
- “LOT” denotes the lot number
- “COO” denotes country of origin.

## 8. Ordering Information

Table 41. Ordering Information

Part Number	Carrier Type	Number of Outputs	Differential Output Impedance ( $\Omega$ )	Package	Temperature Range
RC19024AGNQ#BB0	Tray	24	85	8 × 8 mm, 0.5mm pitch, <a href="#">100-VFQFPN</a>	-40 to +105°C
RC19024AGNQ#KB0	Tape and Reel (EIA-481-D)				
RC19020AGN6#BD0	Tray	20	85	6 × 6 mm, 0.5mm pitch, <a href="#">80-GQFN</a>	-40 to +105°C
RC19020AGN6#KD0	Tape and Reel (EIA-481-D)				
RC19020A072GN2#BB0	Bulk	20	85	10 × 10 mm, 0.50mm pitch <a href="#">72-VFQFPN</a>	-40 to +105°C
RC19020A072GN2#KB0	Tape and Reel (EIA-481-D)				
RC19016AGN1#BB0	Tray	16	85	9 × 9 mm, 0.5mm pitch, <a href="#">64-VFQFPN</a>	-40 to +105°C
RC19016AGN1#KB0	Tape and Reel (EIA-481-D)				
RC19016A100GN1#BB0	Tray		100		
RC19016A100GN1#KB0	Tape and Reel (EIA-481-D)				
RC19013AGNG#BB0	Tray	13	85	7 × 7 mm, 0.4mm pitch, <a href="#">56-VFQFPN</a>	-40 to +105°C
RC19013AGNG#KB0	Tape and Reel (EIA-481-D)				
RC19013A100GNG#BB0	Tray		100		
RC19013A100GNG#KB0	Tape and Reel (EIA-481-D)				
RC19008AGND#BB0	Tray	8	85	5 × 5 mm, 0.4mm pitch, <a href="#">40-VFQFPN</a>	-40 to +105°C
RC19008AGND#KB0	Tape and Reel (EIA-481-D)				
RC19008A100GND#BB0	Tray		100		
RC19008A100GND#KB0	Tape and Reel (EIA-481-D)				
RC19004AGNL#BB0	Tray	4	85	4 × 4 mm, 0.4mm pitch, <a href="#">28-VFQFPN</a>	-40 to +105°C
RC19004AGNL#KB0	Tape and Reel (EIA-481-D)				
RC19004A100GNL#BB0	Tray		100		
RC19004A100GNL#KB0	Tape and Reel (EIA-481-D)				



## 9. Revision History

Revision	Date	Description
1.07	Apr 11, 2022	<ul style="list-style-type: none"> <li>▪ For all devices <i>except</i> RC19020A072:               <ul style="list-style-type: none"> <li>• Updated Pin Type of all pins beginning with OEB to properly indicate internal pull-down (PD) resistors.</li> </ul> </li> <li>▪ For all devices <i>except</i> RC19020A072 and RC19024A:               <ul style="list-style-type: none"> <li>• Removed Power-Down Tolerant indicator from multiplexed OEB SBI_OUT pins, they are not PDT.</li> </ul> </li> <li>▪ Minor reformatting of Pin Descriptions to reduce required space in Pin Description tables and to provide consistency across devices.</li> </ul>
1.06	Apr 4, 2022	<ul style="list-style-type: none"> <li>▪ Updated <a href="#">Loss of Signal and Automatic Clock Parking</a> to change all CLK_IN to CLKIN for consistency.</li> <li>▪ Inserted <a href="#">LOSb De-assert Timing RC19020, RC192xx Devices</a> figure to distinguish the LOSb start-up behavior of those devices from the other devices.</li> </ul>
1.05	Mar 23, 2022	Updated pins B10 and B43 from Do Not Connect (DNC) to GND on <a href="#">RC19024A Pin Assignments</a> to tie off floating pins used for test.
1.04	Mar 15, 2022	Updated the <i>PCI Express Base Specification 6.0</i> revision reference to 1.0 in footnotes 1 and 7 in <a href="#">Table 8</a> and <a href="#">Table 9</a> .
1.03	Mar 3, 2022	<ul style="list-style-type: none"> <li>▪ Corrected pin 10 of RC19008A from NC to VDDCLK (see <a href="#">RC19008A Pin Assignments</a>).</li> </ul>
1.02	Feb 24, 2022	<ul style="list-style-type: none"> <li>▪ Completed minor updates to titles of CLK AC/DC Characteristics Tables for clarity.</li> <li>▪ Completed other minor changes</li> </ul>
1.01	Feb 01, 2022	<ul style="list-style-type: none"> <li>▪ Added RC19020A072 pin out and pin descriptions to data sheet.</li> <li>▪ Updated <a href="#">Figure 9</a> for RC19020A and RC19020A072.</li> <li>▪ Updated <a href="#">Figure 2</a> title to reference correct package type (VFQFPN) and updated “100-GQFN” references to “100-VFQFPN” throughout the document.</li> <li>▪ Added RC19020A072 marking diagram to <a href="#">RC1902xA Marking Diagrams</a> and updated marking descriptions of RC19020A and RC19020A072.</li> </ul>
1.00	Jan 18, 2022	Initial release.

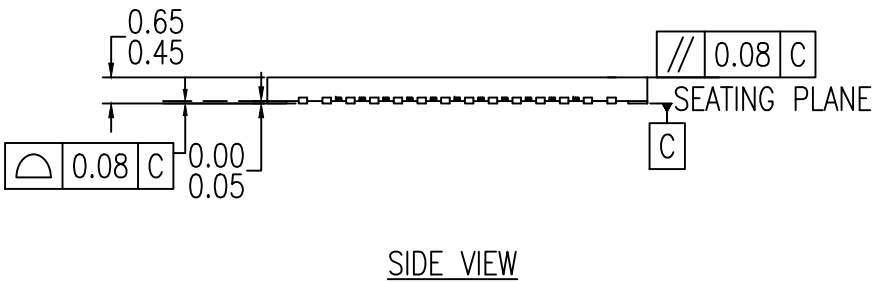
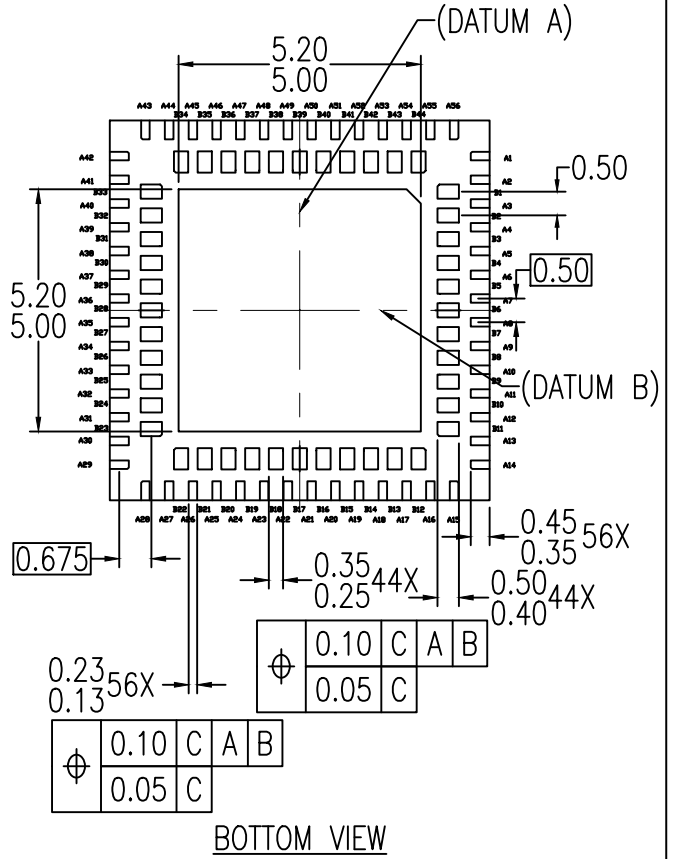
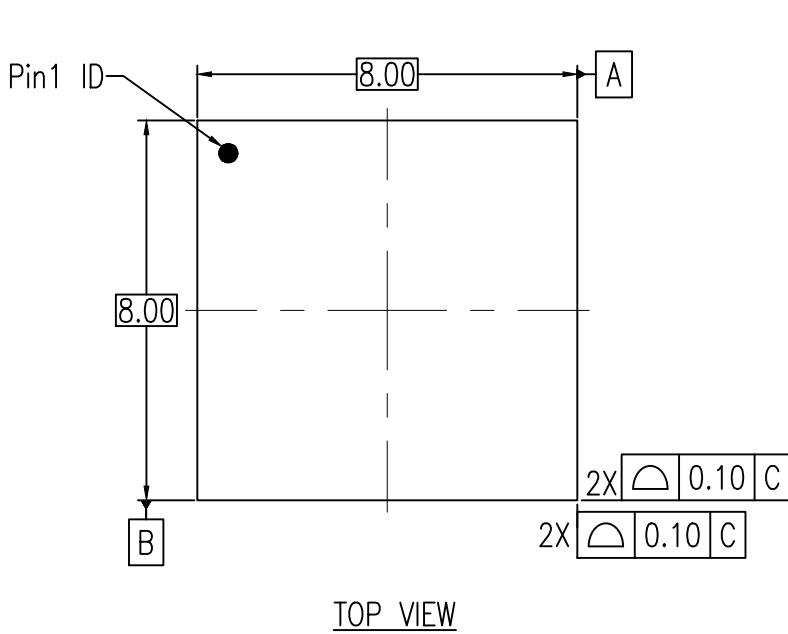

NOTES:

1. ALL DIMENSIONS AND TOLERANCES ARE PER ASME Y14.5M-1994.
2. ALL DIMENSIONS ARE IN MILLIMETERS.

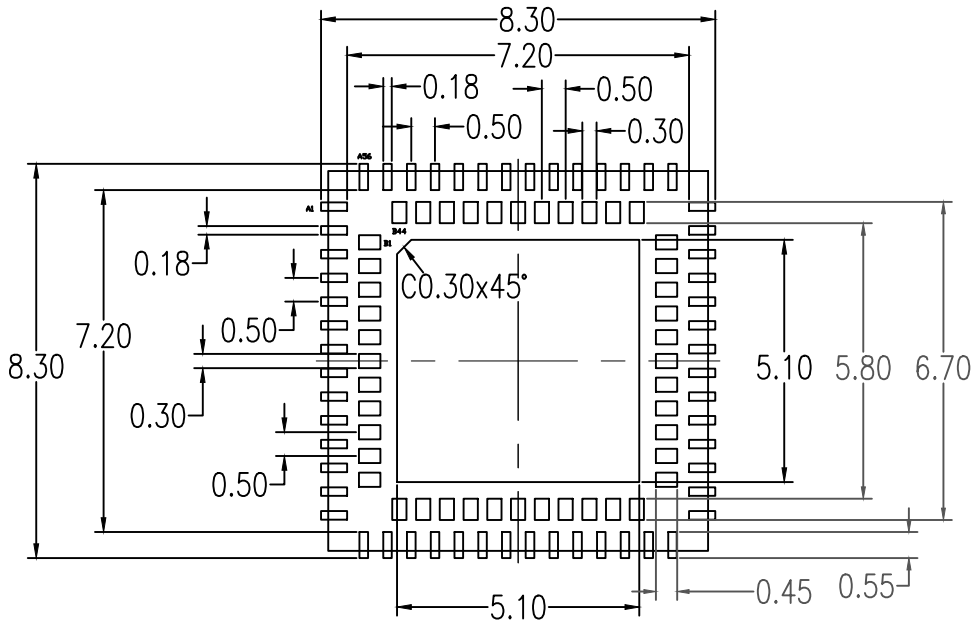

RECOMMENDED LAND PATTERN DIMENSION

NOTES:

1. ALL DIMENSIONS ARE IN MM, ANGLES IN DEGREES.
2. TOP DOWN VIEW, AS VIEW ON PCB.
3. NSMD LAND PATTERN ASSUMED.
4. LAND PATTERN RECOMMENDATION AS PR IPC-7351  
 GENERIC REQUIREMENT FOR SURFACE MOUNT DESIGN AND LAND PATTERN.

Package Revision History		
Date Created	Rev No.	Description
August 12, 2019	Rev 00	Initial Release

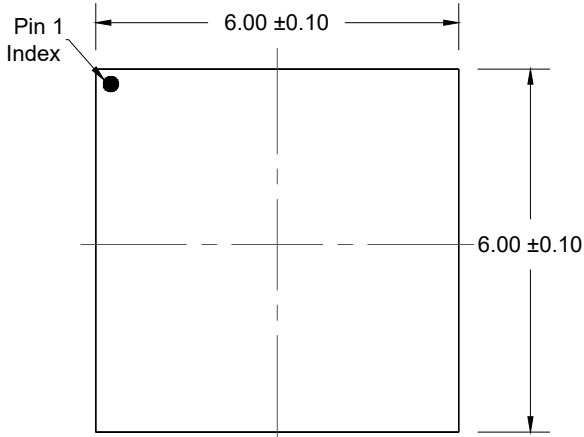

TOP VIEW

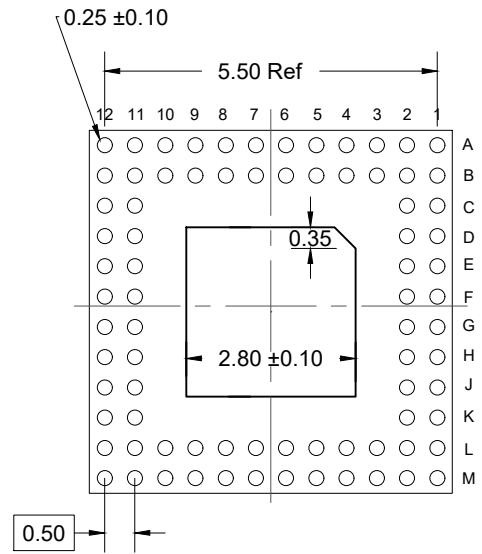

BOTTOM VIEW

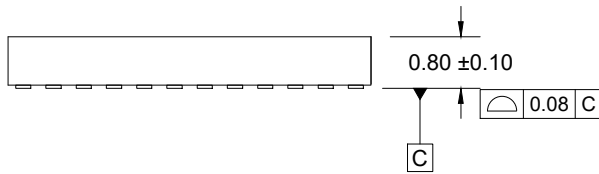

SIDE VIEW

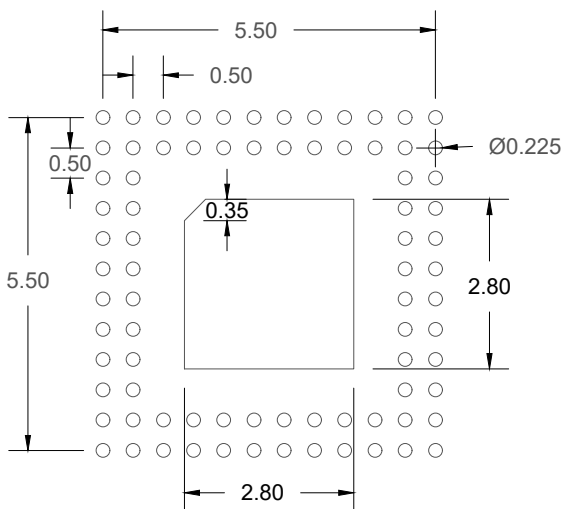

RECOMMENDED LAND PATTERN

(PCB Top View, NSMD Design)

**NOTES:**

1. JEDEC compatible
2. All dimensions are in mm and angles are in degrees
3. Use  $\pm 0.05$  mm tolerance for all other dimensions
4. Numbers in ( ) are for reference only

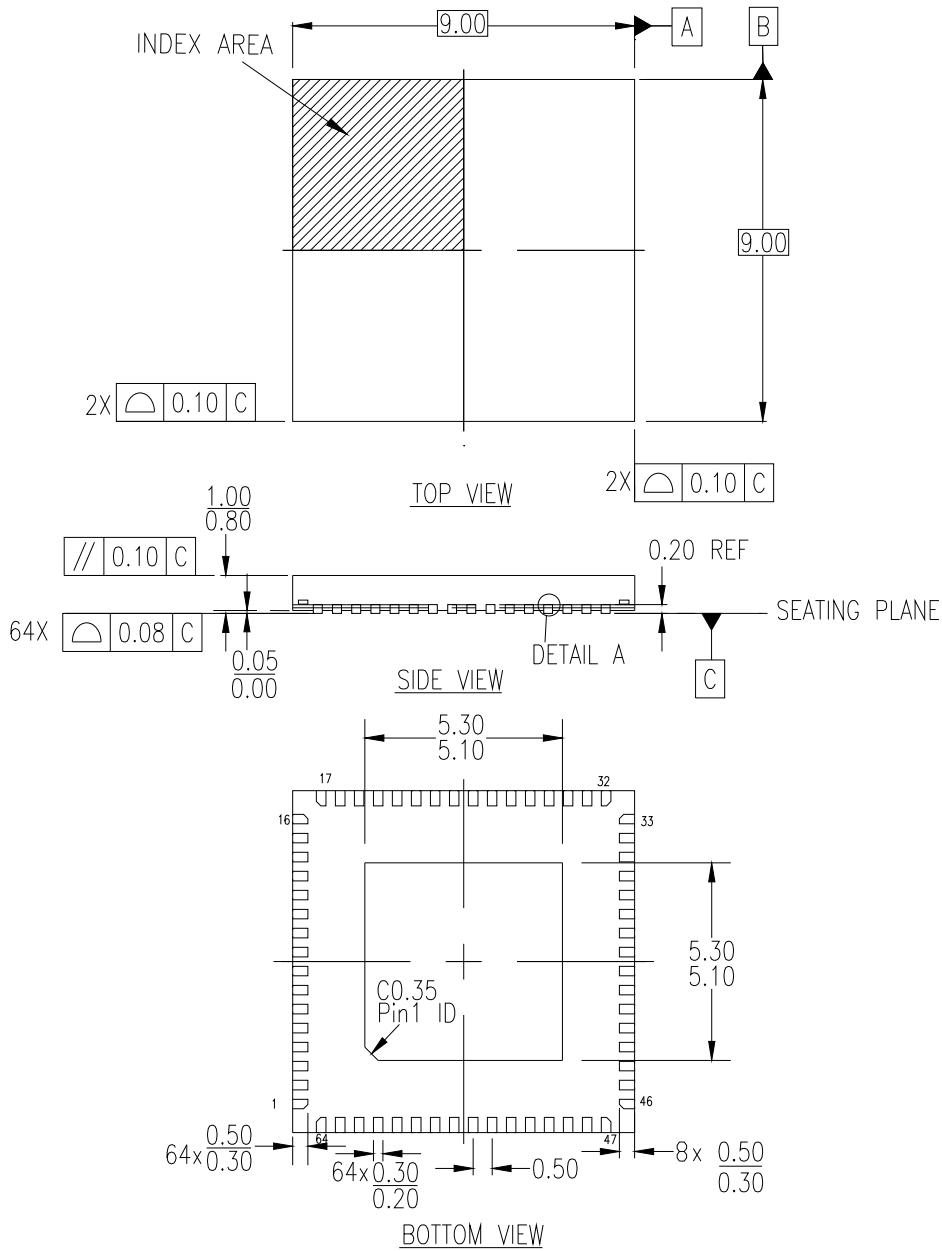

NOTES:

1. ALL DIMENSIONING AND TOLERANCEING CONFORM TO ANSI Y14.5M-1982
2. ALL DIMENSIONS ARE IN MILLIMETERS
3. INDEX AREA PIN 1 IDENTIFIER

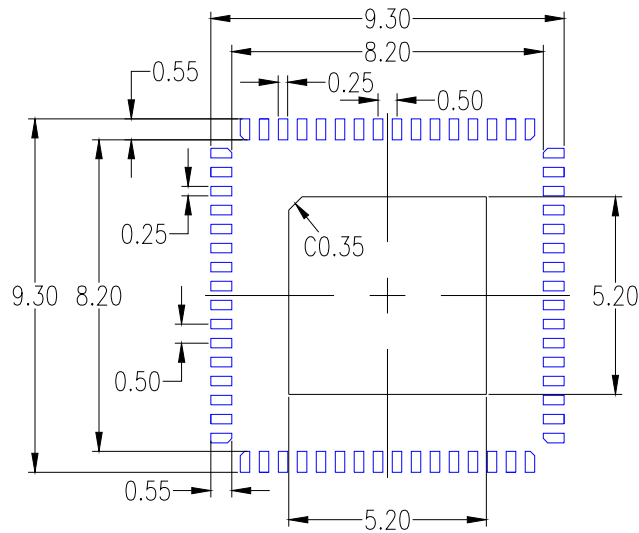

RECOMMENDED LAND PATTERN DIMENSION

NOTES:

1. ALL DIMENSIONING AND TOLERANCING CONFORM TO ANSI Y14.5M-1982
2. ALL DIMENSIONS ARE IN MILLIMETERS
3. LAND PATTERN RECOMMENDATION PER IPC-7351B GENERIC REQUIREMENT FOR SURFACE MOUNT DESIGN AND LAND PATTERN

Package Revision History		
Date Created	Rev No.	Description
Jan 13, 2021	Rev 00	Initial Release

REVISIONS			
REV	DESCRIPTION	DATE	APPROVED
00	INITIAL RELEASE	5/18/16	JH

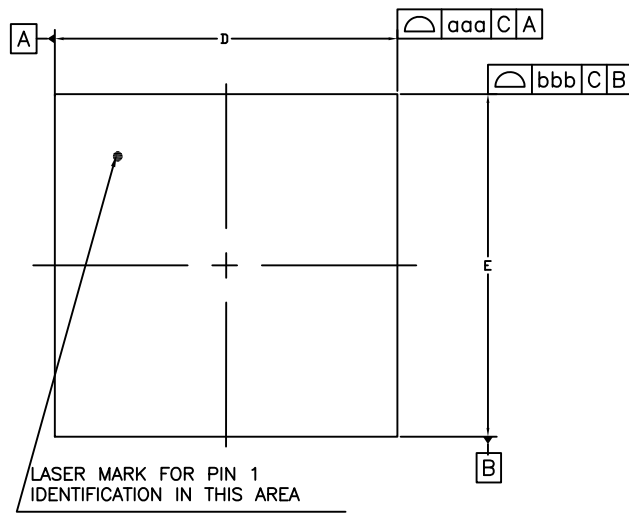

TOP VIEW

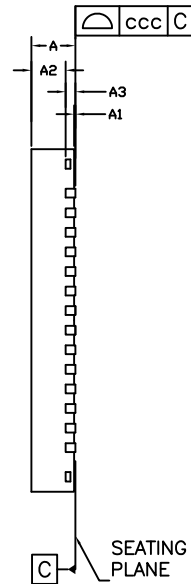

SIDE VIEW

DIMENSION

SYMBOL	MIN.	NOM.	MAX.
A	0.80	0.90	1.00
A1	0.00	0.02	0.05
A2	---	0.65	0.70
A3	0.20 REF.		
b	0.15	0.20	0.25
D	7.00 BSC		
E	7.00 BSC		
D2	5.20	5.30	5.40
E2	5.20	5.30	5.40
L	0.30	0.40	0.50
k	0.450 REF.		
e	0.40 BSC		
aaa	0.10		
bbb	0.10		
ccc	0.05		

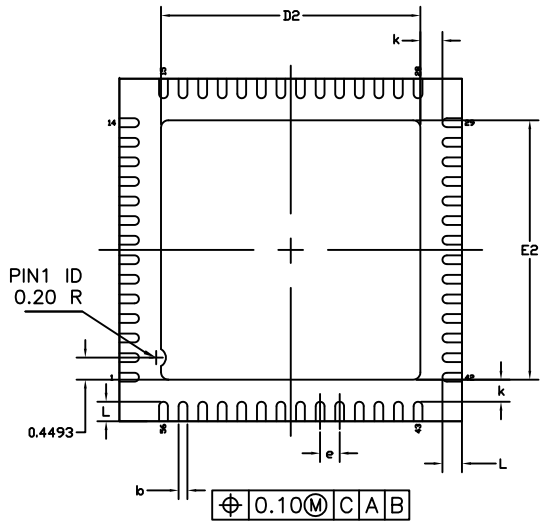

BOTTOM VIEW

NOTES :

- 1.ALL DIMENSIONS ARE IN MILLIMETERS.
- 2.DIE THICKNESS ALLOWABLE IS 0.305 mm MAXIMUM(.012 INCHES MAXIMUM)
- 3.DIMENSIONING & TOLERANCES CONFORM TO ASME Y14.5M. -1994.
- 4.THE PIN #1 IDENTIFIER MUST BE PLACED ON THE TOP SURFACE OF THE PACKAGE BY USING INDENTATION MARK OR OTHER FEATURE OF PACKAGE BODY.
- 5.EXACT SHAPE AND SIZE OF THIS FEATURE IS OPTIONAL.
- 6.PACKAGE WARPAGE MAX 0.08 mm.
- 7.APPLIED FOR EXPOSED PAD AND TERMINALS. EXCLUDE EMBEDDING PART OF EXPOSED PAD FROM MEASURING.
- 8.APPLIED ONLY TO TERMINALS.

TOLERANCES UNLESS SPECIFIED		6024 Silver Creek Valley Road	
DECIMAL	ANGULAR	San Jose, CA 95138	
XX±	±	PHONE: (408) 284-8200	
XXX±		www.IDT.com	
XXXX±		FAX: (408) 284-8591	
APPROVALS	DATE	TITLE	
DRAWN <i>oac</i>	07/01/13	ND/NDG56 PACKAGE OUTLINE	
CHECKED		7.0 x 7.0 mm BODY, EPAD 5.30mm SQ	
		0.40 mm PITCH QFN	
		SIZE	REV
		C	00
		DRAWING No. PSC-4398-01	
DO NOT SCALE DRAWING		SHEET 1 OF 2	

REVISIONS			
REV	DESCRIPTION	DATE	APPROVED
00	INITIAL RELEASE	5/18/16	JH

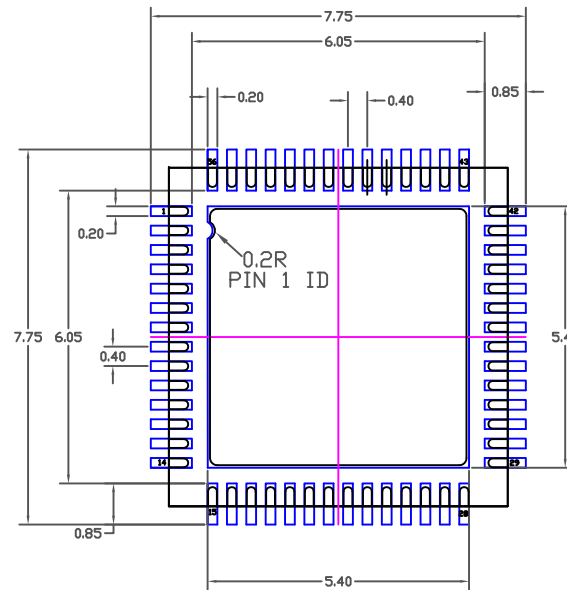

RECOMMENDED LAND PATTERN DIMENSION

NOTES:

1. ALL DIMENSIONS ARE IN mm. ANGLES IN DEGREES.
2. TOP DOWN VIEW. AS VIEWED ON PCB.
3. COMPONENT OUTLINE SHOWS FOR REFERENCE IN BLACK.
4. LAND PATTERN IN BLUE. NSMD PATTERN ASSUMED.
5. LAND PATTERN RECOMMENDATION PER IPC-7351B GENERIC REQUIREMENT FOR MOUNT DESIGN AND LAND PATTERN.

TOLERANCES UNLESS SPECIFIED		6024 Silver Creek Valley Road San Jose, CA 95138	
DECIMAL	ANGULAR	PHONE: (408) 284-8200	
XX±	±	FAX: (408) 284-8591	
XXX±		<b>IDT</b> www.IDT.com	
XXXX±		TITLE ND/NDG56 PACKAGE OUTLINE 7.0 x 7.0 mm BODY, EPAD 5.30mm SQ 0.40 mm PITCH QFN	
APPROVALS	DATE	SIZE	REV
DRAWN <i>RLC</i>	07/01/13	C	00
CHECKED		DRAWING No. PSC-4398-01	
DO NOT SCALE DRAWING			SHEET 2 OF 2



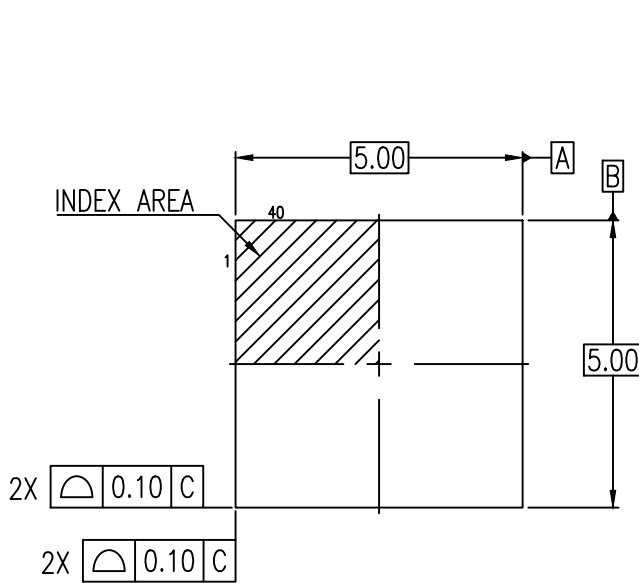

TOP VIEW

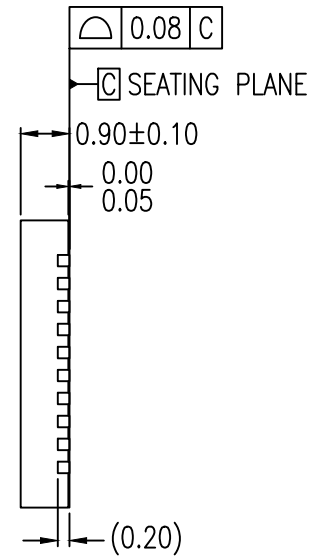

SIDE VIEW

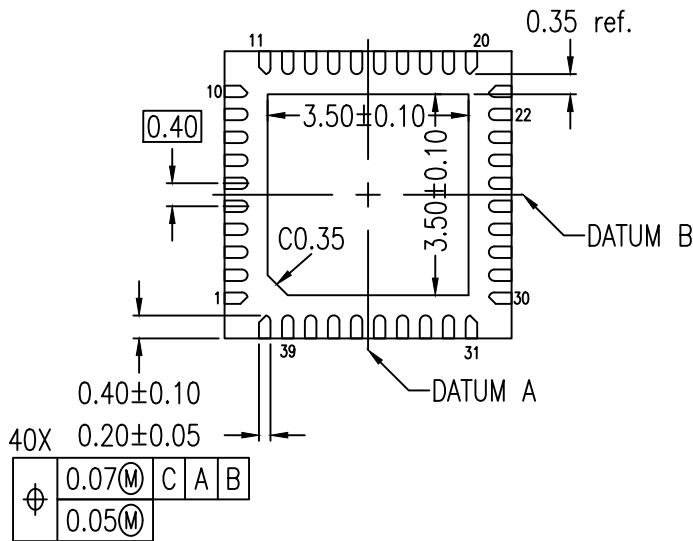

BOTTOM VIEW

NOTES:

1. DIMENSIONING AND TOLERANCING CONFORM TO ASME Y14.5-2009
2. ALL DIMENSIONS ARE IN MILLIMETERS

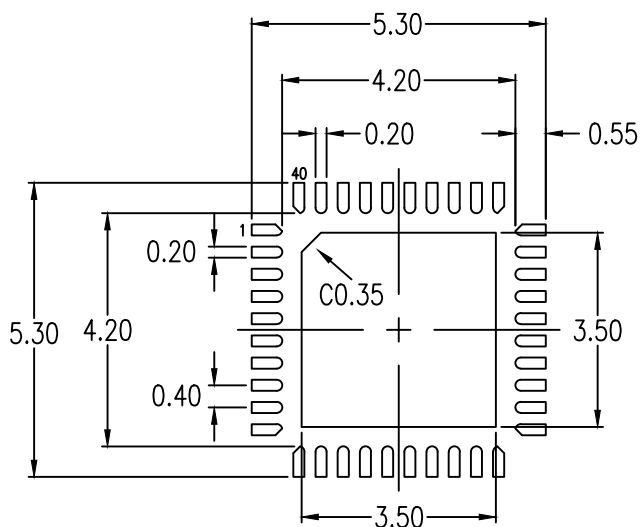

RECOMMENDED LAND PATTERN DIMENSION

NOTES:

1. ALL DIMENSIONS ARE IN MM. ANGLES IN DEGREES
2. TOP DOWN VIEW. AS VIEWED ON PCB
3. LAND PATTERN RECOMMENDATION PER IPC-7351B GENERIC REQUIREMENT FOR SURFACE MOUNT DESIGN AND LAND PATTERN.
4. NSMD PATTERN ASSUMED

Package Revision History		
Date Created	Rev No.	Description
Feb 25, 2021	01	Update Template to Marketing Version
May 17, 2016	00	Initial release

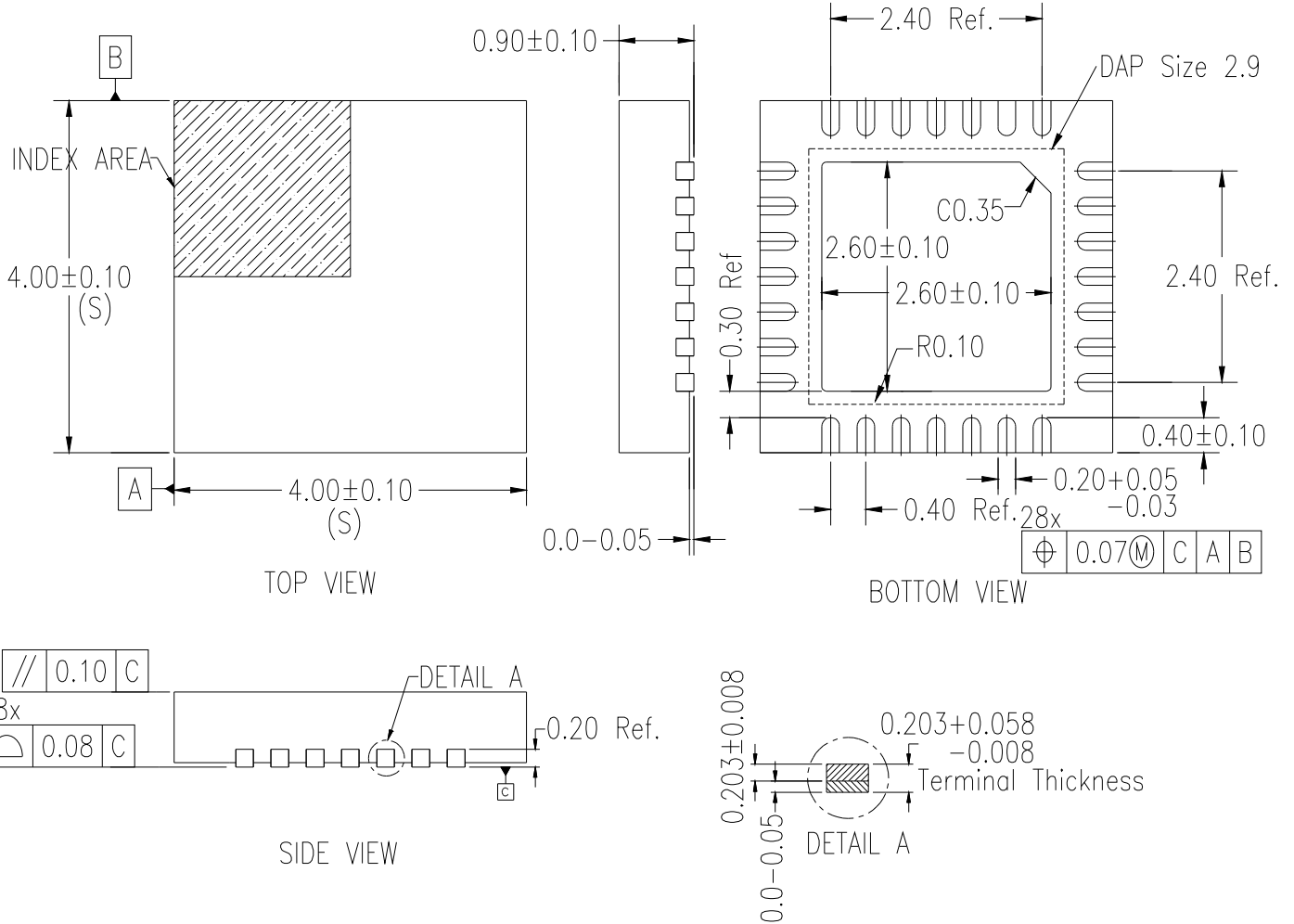

NOTES:

1. ALL DIMENSION ARE IN MM. ANGLES IN DEGREES.
2. COPLANARITY APPLIES TO THE EXPOSED PAD AS WELL AS THE TERMINALS. COPLANARITY SHALL NOT EXCEED 0.08 MM.
3. WARPAGE SHALL NOT EXCEED 0.10 MM.
4. PACKAGE LENGTH/ PACKAGE WIDTH ARE CONSIDERED AS SPECIAL CHARACTERISTIC (S)
5. REFER JEDEC MO-220

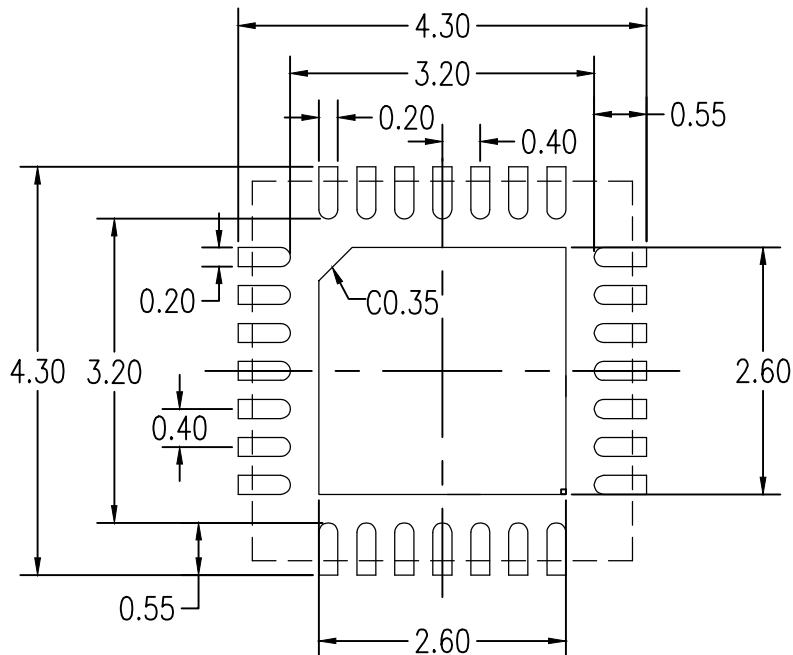

RECOMMENDED LAND PATTERN DIMENSION

NOTES:

1. ALL DIMENSION ARE IN MM. ANGLES IN DEGREES.
2. TOP DOWN VIEW. AS VIEWED ON PCB.
3. LAND PATTERN IN NSMD PATTERN ASSUMED.
4. LAND PATTERN RECOMMENDATION PER IPC-7351B GENERIC REQUIREMENT FOR SURFACE MOUNT DESIGN AND LAND PATTERN.

Package Revision History		
Date Created	Rev No.	Description
April 5, 2021	00	Initial Release
May 20, 2021	01	Remove word "ball" from the description title

## IMPORTANT NOTICE AND DISCLAIMER

RENESAS ELECTRONICS CORPORATION AND ITS SUBSIDIARIES (“RENESAS”) PROVIDES TECHNICAL SPECIFICATIONS AND RELIABILITY DATA (INCLUDING DATASHEETS), DESIGN RESOURCES (INCLUDING REFERENCE DESIGNS), APPLICATION OR OTHER DESIGN ADVICE, WEB TOOLS, SAFETY INFORMATION, AND OTHER RESOURCES “AS IS” AND WITH ALL FAULTS, AND DISCLAIMS ALL WARRANTIES, EXPRESS OR IMPLIED, INCLUDING, WITHOUT LIMITATION, ANY IMPLIED WARRANTIES OF MERCHANTABILITY, FITNESS FOR A PARTICULAR PURPOSE, OR NON-INFRINGEMENT OF THIRD PARTY INTELLECTUAL PROPERTY RIGHTS.

These resources are intended for developers skilled in the art designing with Renesas products. You are solely responsible for (1) selecting the appropriate products for your application, (2) designing, validating, and testing your application, and (3) ensuring your application meets applicable standards, and any other safety, security, or other requirements. These resources are subject to change without notice. Renesas grants you permission to use these resources only for development of an application that uses Renesas products. Other reproduction or use of these resources is strictly prohibited. No license is granted to any other Renesas intellectual property or to any third party intellectual property. Renesas disclaims responsibility for, and you will fully indemnify Renesas and its representatives against, any claims, damages, costs, losses, or liabilities arising out of your use of these resources. Renesas' products are provided only subject to Renesas' Terms and Conditions of Sale or other applicable terms agreed to in writing. No use of any Renesas resources expands or otherwise alters any applicable warranties or warranty disclaimers for these products.

(Rev.1.0 Mar 2020)

### Corporate Headquarters

TOYOSU FORESIA, 3-2-24 Toyosu,  
Koto-ku, Tokyo 135-0061, Japan  
[www.renesas.com](http://www.renesas.com)

### Contact Information

For further information on a product, technology, the most up-to-date version of a document, or your nearest sales office, please visit:  
[www.renesas.com/contact/](http://www.renesas.com/contact/)

### Trademarks

Renesas and the Renesas logo are trademarks of Renesas Electronics Corporation. All trademarks and registered trademarks are the property of their respective owners.