

To our customers,

Old Company Name in Catalogs and Other Documents

On April 1st, 2010, NEC Electronics Corporation merged with Renesas Technology Corporation, and Renesas Electronics Corporation took over all the business of both companies. Therefore, although the old company name remains in this document, it is a valid Renesas Electronics document. We appreciate your understanding.

Renesas Electronics website: <http://www.renesas.com>

April 1st, 2010
Renesas Electronics Corporation

Issued by: Renesas Electronics Corporation (<http://www.renesas.com>)

Send any inquiries to <http://www.renesas.com/inquiry>.

Notice

1. All information included in this document is current as of the date this document is issued. Such information, however, is subject to change without any prior notice. Before purchasing or using any Renesas Electronics products listed herein, please confirm the latest product information with a Renesas Electronics sales office. Also, please pay regular and careful attention to additional and different information to be disclosed by Renesas Electronics such as that disclosed through our website.
2. Renesas Electronics does not assume any liability for infringement of patents, copyrights, or other intellectual property rights of third parties by or arising from the use of Renesas Electronics products or technical information described in this document. No license, express, implied or otherwise, is granted hereby under any patents, copyrights or other intellectual property rights of Renesas Electronics or others.
3. You should not alter, modify, copy, or otherwise misappropriate any Renesas Electronics product, whether in whole or in part.
4. Descriptions of circuits, software and other related information in this document are provided only to illustrate the operation of semiconductor products and application examples. You are fully responsible for the incorporation of these circuits, software, and information in the design of your equipment. Renesas Electronics assumes no responsibility for any losses incurred by you or third parties arising from the use of these circuits, software, or information.
5. When exporting the products or technology described in this document, you should comply with the applicable export control laws and regulations and follow the procedures required by such laws and regulations. You should not use Renesas Electronics products or the technology described in this document for any purpose relating to military applications or use by the military, including but not limited to the development of weapons of mass destruction. Renesas Electronics products and technology may not be used for or incorporated into any products or systems whose manufacture, use, or sale is prohibited under any applicable domestic or foreign laws or regulations.
6. Renesas Electronics has used reasonable care in preparing the information included in this document, but Renesas Electronics does not warrant that such information is error free. Renesas Electronics assumes no liability whatsoever for any damages incurred by you resulting from errors in or omissions from the information included herein.
7. Renesas Electronics products are classified according to the following three quality grades: “Standard”, “High Quality”, and “Specific”. The recommended applications for each Renesas Electronics product depends on the product’s quality grade, as indicated below. You must check the quality grade of each Renesas Electronics product before using it in a particular application. You may not use any Renesas Electronics product for any application categorized as “Specific” without the prior written consent of Renesas Electronics. Further, you may not use any Renesas Electronics product for any application for which it is not intended without the prior written consent of Renesas Electronics. Renesas Electronics shall not be in any way liable for any damages or losses incurred by you or third parties arising from the use of any Renesas Electronics product for an application categorized as “Specific” or for which the product is not intended where you have failed to obtain the prior written consent of Renesas Electronics. The quality grade of each Renesas Electronics product is “Standard” unless otherwise expressly specified in a Renesas Electronics data sheets or data books, etc.
 - “Standard”: Computers; office equipment; communications equipment; test and measurement equipment; audio and visual equipment; home electronic appliances; machine tools; personal electronic equipment; and industrial robots.
 - “High Quality”: Transportation equipment (automobiles, trains, ships, etc.); traffic control systems; anti-disaster systems; anti-crime systems; safety equipment; and medical equipment not specifically designed for life support.
 - “Specific”: Aircraft; aerospace equipment; submersible repeaters; nuclear reactor control systems; medical equipment or systems for life support (e.g. artificial life support devices or systems), surgical implantations, or healthcare intervention (e.g. excision, etc.), and any other applications or purposes that pose a direct threat to human life.
8. You should use the Renesas Electronics products described in this document within the range specified by Renesas Electronics, especially with respect to the maximum rating, operating supply voltage range, movement power voltage range, heat radiation characteristics, installation and other product characteristics. Renesas Electronics shall have no liability for malfunctions or damages arising out of the use of Renesas Electronics products beyond such specified ranges.
9. Although Renesas Electronics endeavors to improve the quality and reliability of its products, semiconductor products have specific characteristics such as the occurrence of failure at a certain rate and malfunctions under certain use conditions. Further, Renesas Electronics products are not subject to radiation resistance design. Please be sure to implement safety measures to guard them against the possibility of physical injury, and injury or damage caused by fire in the event of the failure of a Renesas Electronics product, such as safety design for hardware and software including but not limited to redundancy, fire control and malfunction prevention, appropriate treatment for aging degradation or any other appropriate measures. Because the evaluation of microcomputer software alone is very difficult, please evaluate the safety of the final products or system manufactured by you.
10. Please contact a Renesas Electronics sales office for details as to environmental matters such as the environmental compatibility of each Renesas Electronics product. Please use Renesas Electronics products in compliance with all applicable laws and regulations that regulate the inclusion or use of controlled substances, including without limitation, the EU RoHS Directive. Renesas Electronics assumes no liability for damages or losses occurring as a result of your noncompliance with applicable laws and regulations.
11. This document may not be reproduced or duplicated, in any form, in whole or in part, without prior written consent of Renesas Electronics.
12. Please contact a Renesas Electronics sales office if you have any questions regarding the information contained in this document or Renesas Electronics products, or if you have any other inquiries.

(Note 1) “Renesas Electronics” as used in this document means Renesas Electronics Corporation and also includes its majority-owned subsidiaries.

(Note 2) “Renesas Electronics product(s)” means any product developed or manufactured by or for Renesas Electronics.

7500 PIXELS × 3 COLOR CCD LINEAR IMAGE SENSOR

DESCRIPTION

The μPD8828A is a high-speed and high sensitive color CCD (Charge Coupled Device) linear image sensor which changes optical images to electrical signal and has the function of color separation.

The μPD8828A has 3 rows of 7500 pixels, and it is a 2-output/color type CCD sensor with 2 rows/color of charge transfer register, which transfers the photo signal electrons of 7500 pixels separately in odd and even pixels.

Therefore, it is suitable for 600 dpi/A3 high-speed color digital copiers, color scanners and so on.

FEATURES

- Valid photocell : 7500 pixels × 3
- Photocell pitch : 4.7 μm
- Line spacing : 37.6 μm (8 lines) Red line-Green line, Green line-Blue line
- Color filter : Primary colors (red, green, and blue), pigment filter
Light resistance is 10⁷ lx•hour with standard sunlight and ultraviolet cut filter (L40)
- Resolution : 24 dot/mm A3 (297 × 420 mm) size (shorter side)
- Data rate : 40 MHz MAX. (20 MHz/ch max.)
- Output type : 2 outputs in phase/color
- Power supply : +10 V
- Drive clock level : CMOS output under 5 V operation
- On-chip circuits : Reset feed-through level clamp circuit
Voltage amplifiers

ORDERING INFORMATION

Part Number	Package
<R> μPD8828AD-A	CCD linear image sensor 22-pin ceramic DIP (CERDIP) (10.16 mm (400))

Remark The μPD8828AD-A is a lead-free product.

The information in this document is subject to change without notice. Before using this document, please confirm that this is the latest version.
Not all products and/or types are available in every country. Please check with an NEC Electronics sales representative for availability and additional information.

BLOCK DIAGRAM

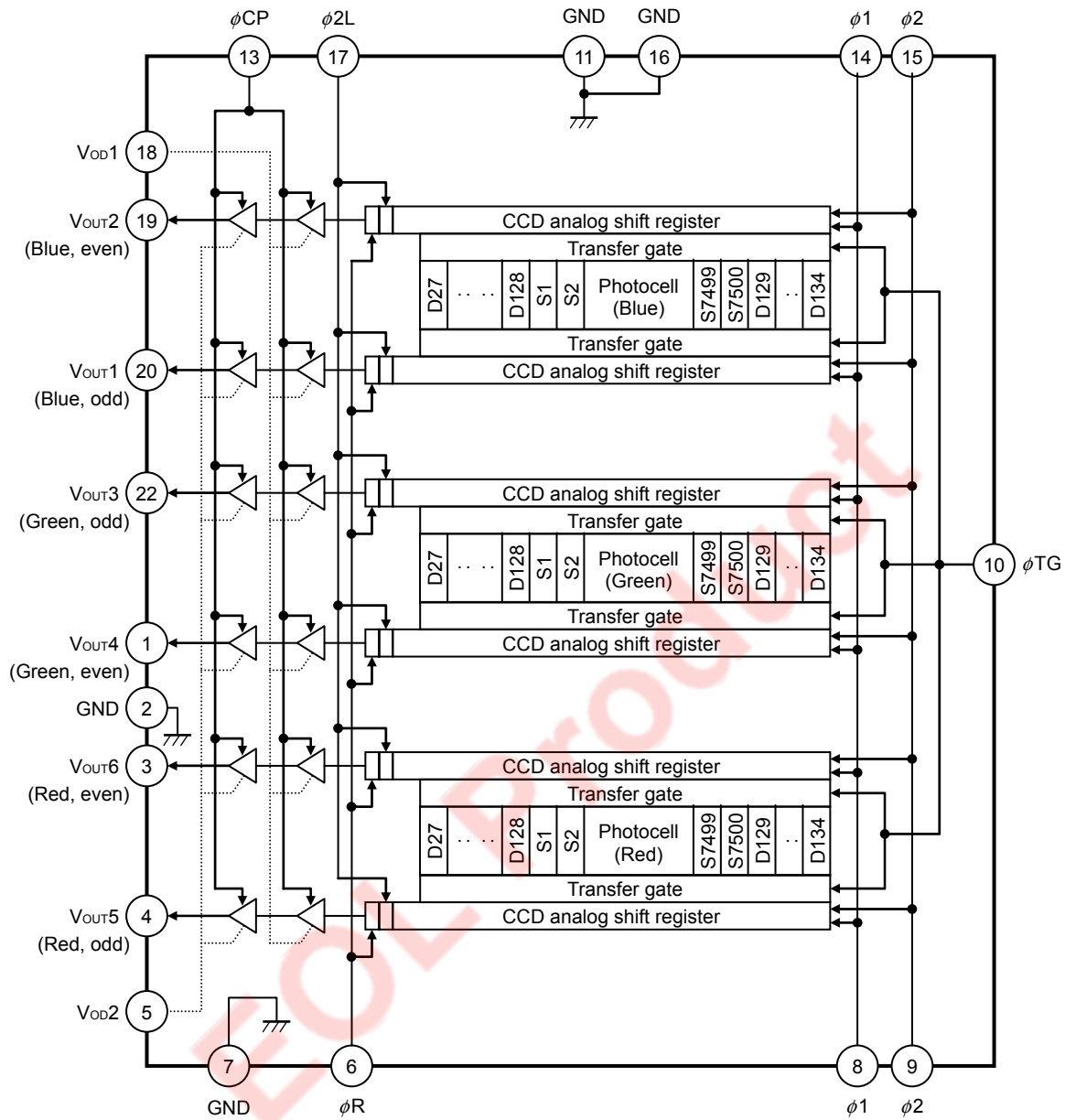

PIN CONFIGURATION (Top View)

CCD linear image sensor 22-pin ceramic DIP (CERDIP) (10.16 mm (400))
μPD8828AD-A

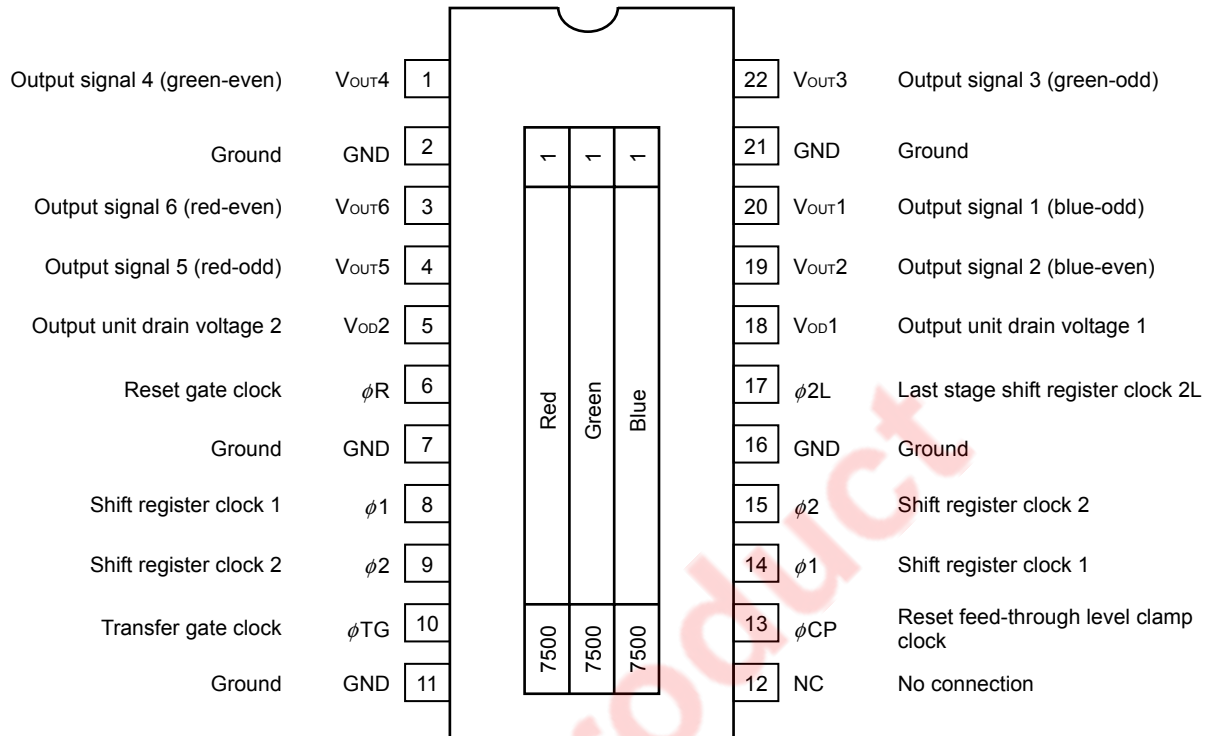

PHOTOCELL STRUCTURE DIAGRAM

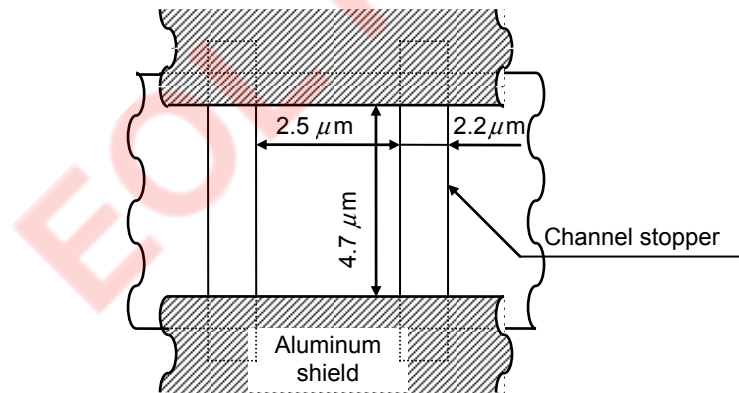

ABSOLUTE MAXIMUM RATINGS (T_A = +25°C)

Parameter	Symbol	Ratings	Unit
Output drain voltage	V _{OD1} , V _{OD2}	-0.3 to +12.0	V
Shift register clock voltage	V _{φ1} , V _{φ2}	-0.3 to +8.0	V
Last stage shift register clock voltage	V _{φ2L}	-0.3 to +8.0	V
Reset gate clock voltage	V _{φR}	-0.3 to +8.0	V
Reset feed-through level clamp clock voltage	V _{φCP}	-0.3 to +8.0	V
Transfer gate clock voltage	V _{φTG}	-0.3 to +8.0	V
Operating ambient temperature ^{Note}	T _A	0 to +60	°C
Storage temperature	T _{stg}	-40 to +100	°C

Note The operating ambient temperature is defined as an atmosphere temperature in a point 10 mm away on the substrate, and 10 mm away from the short side of package 1 pin. Use at the condition without dewy condensation.

Caution Product quality may suffer if the absolute maximum rating is exceeded even momentarily for any parameter. That is, the absolute maximum ratings are rated values at which the product is on the verge of suffering physical damage, and therefore the product must be used under conditions that ensure that the absolute maximum ratings are not exceeded.

RECOMMENDED OPERATING CONDITIONS (T_A = +25°C)

Parameter	Symbol	MIN.	TYP.	MAX.	Unit
Output drain voltage	V _{OD1} , V _{OD2}	9.5	10.0	10.5	V
Shift register clock high level	V _{φ1H} , V _{φ2H}	4.75	5.0	6.0	V
Shift register clock low level	V _{φ1L} , V _{φ2L}	-0.3	0.0	+0.5	V
Last stage shift register clock high level	V _{φ2LH}	4.75	5.0	6.0	V
Last stage shift register clock low level	V _{φ2LL}	-0.3	0.0	+0.5	V
Reset gate clock high level	V _{φRH}	4.75	5.0	5.5	V
Reset gate clock low level	V _{φRL}	-0.3	0.0	+0.5	V
Reset feed-through level clamp clock high level	V _{φCPH}	4.75	5.0	6.0	V
Reset feed-through level clamp clock low level	V _{φCPL}	-0.3	0.0	+0.5	V
Transfer gate clock high level ^{Note}	V _{φTGH}	4.75	V _{φ1H}	V _{φ1H}	V
Transfer gate clock low level	V _{φTGL}	-0.3	0.0	+0.5	V
Shift register clock amplitude	V _{φ1p-p} , V _{φ2p-p}	4.75	5.0	6.3	V
Last stage shift register clock amplitude	V _{φ2Lp-p}	4.75	5.0	6.3	V
Reset gate clock amplitude	V _{φRp-p}	4.75	5.0	6.3	V
Reset feed-through level clamp clock amplitude	V _{φCPp-p}	4.5	5.0	6.3	V
Transfer gate clock amplitude	V _{φTgp-p}	4.75	5.0	6.3	V
Data rate	2 × f _{φR}	0.2	2	40	MHz

Note When Transfer gate clock high level (V_{φTGH}) is higher than shift register clock high level (V_{φ1H}), image lag can increase.

ELECTRICAL CHARACTERISTICS

($T_A = +25^{\circ}\text{C}$, $V_{OD} = +10\text{ V}$, $f_{\phi R} = 1\text{ MHz}$, data rate = 2 MHz, storage time = 10 ms, input clock = 5 V_{P-P}
light source: 3200 K halogen lamp + C-500S (infrared cut filter, $t = 1\text{ mm}$) + HA-50 (heat absorbing filter, $t = 3\text{ mm}$) (except Response 2))

Parameter	Symbol	Test Conditions	MIN.	TYP.	MAX.	Unit	
Saturation voltage	Vsat		1.5	2.0	–	V	
Saturation exposure	Red	SER	3200K+C500S+HA50	–	0.17	–	$\text{l}\cdot\text{s}$
	Green	SEG		–	0.2	–	$\text{l}\cdot\text{s}$
	Blue	SEB		–	0.37	–	$\text{l}\cdot\text{s}$
Photo response non-uniformity	PRNU	$V_{OUT} = 1\text{ V}$	–	6.0	18.0	%	
Average dark signal	ADS	Light shielding	–	1.0	5.0	mV	
Dark signal non-uniformity	DSNU	Light shielding	–	2.0	10.0	mV	
Power consumption 1	P _{OD1}		–	130	150	mW	
Power consumption 2	P _{OD2}		–	340	400	mW	
Output impedance	Z _o		–	0.2	0.4	kΩ	
Response 1	Red	R _R	3200K+C500S+HA50	8.47	12.1	15.73	$\text{V}/\text{l}\cdot\text{s}$
	Green	R _G		6.93	9.9	12.87	$\text{V}/\text{l}\cdot\text{s}$
	Blue	R _B		3.78	5.4	7.02	$\text{V}/\text{l}\cdot\text{s}$
Response 2 (corresponding value from Response 1)	Red	R _R	A light source+CM500S	6.30	9.0	11.70	$\text{V}/\text{l}\cdot\text{s}$
	Green	R _G		5.81	8.3	10.79	$\text{V}/\text{l}\cdot\text{s}$
	Blue	R _B		2.66	3.8	4.94	$\text{V}/\text{l}\cdot\text{s}$
Response peak	Red			–	610	–	nm
	Green			–	535	–	nm
	Blue			–	460	–	nm
Image lag	IL	$V_{OUT} = 1\text{ V}$	–	3.0	5.0	%	
Offset level	V _{OS}		3.9	4.9	5.9	V	
Output fall delay time ^{Note}	t _d		13	15	17	ns	
Register imbalance	RI	$V_{OUT} = 1\text{ V}$	–	0	8	%	
Total transfer efficiency	TTE	$V_{OUT} = 1\text{ V}$, $f_{\phi R} = 20\text{ MHz}$	94	98	–	%	
Dynamic range	DR1	V_{sat}/DSNU	–	1000	–	times	
	DR2	V_{sat}/σ	–	1333	–	times	
Reset feed-through noise	RFTN	Light shielding	–1000	–200	+500	mV	
Light shielding random noise	σ_{dark}	Bit clamp, $t_{17} > 8\text{ ns}$	–	1.5	–	mV	

Note t_d is defined as period from 10% of $\phi 2L$ of V_{out1} to V_{out6}, and t_d is reference data after V_{out1} to V_{out6} pins with FET proving.

INPUT PIN CAPACITANCE (T_A = +25°C, V_{OD} = +10 V)

Parameter	Symbol	Pin	Pin No	MIN.	TYP.	MAX.	Unit
Shift register clock pin capacitance ^{Note}	C _{φ1}	φ1	8	360	400	440	pF
		φ1	14	360	400	440	pF
	φ1 total capacitance			720	800	880	pF
	C _{φ2}	φ2	9	360	400	440	pF
		φ2	15	360	400	440	pF
	φ2 total capacitance			720	800	880	pF
Last stage shift register clock pin capacitance	C _{φ2L}	φ2L	17	14	15	17	pF
Reset gate clock pin capacitance	C _{φR}	φR	6	20	22	24	pF
Reset feed-through level clamp clock pin capacitance	C _{φCP}	φCP	13	35	39	43	pF
Transfer gate clock pin capacitance	C _{φTG}	φTG	10	225	250	275	pF

Note C_{φ1}, C_{φ2} are equivalent capacitance with driving device, including the co-capacitance between φ1 and φ2.

Remark Pins 8 and 14 (φ1), pins 9 and 15 (φ2) are each connected inside of the device.

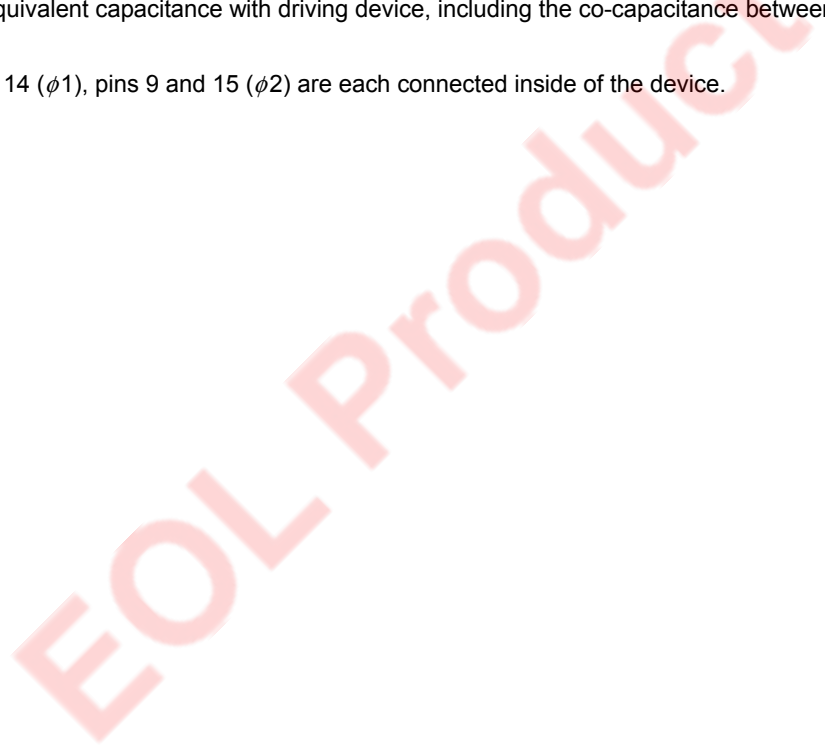

TIMING CHART 1

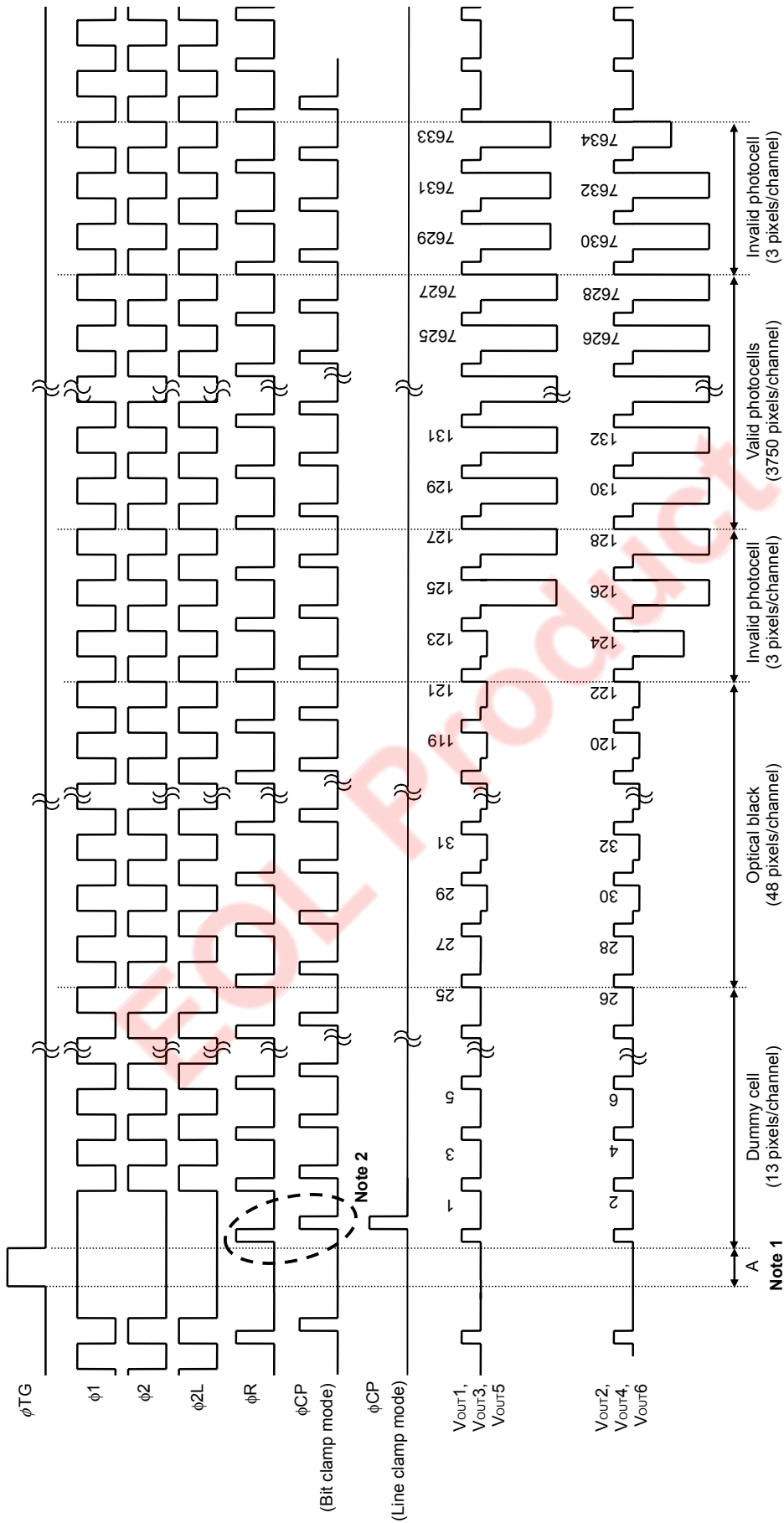

- Notes 1.** Set the ϕ_R and ϕ_{CP} to low level during this period (A).
- 2.** The ϕ_R and ϕ_{CP} pulses which surrounded with the dashed line are omissible at the bit clamp mode.

TIMING CHART 2 (Bit Clamp Mode)

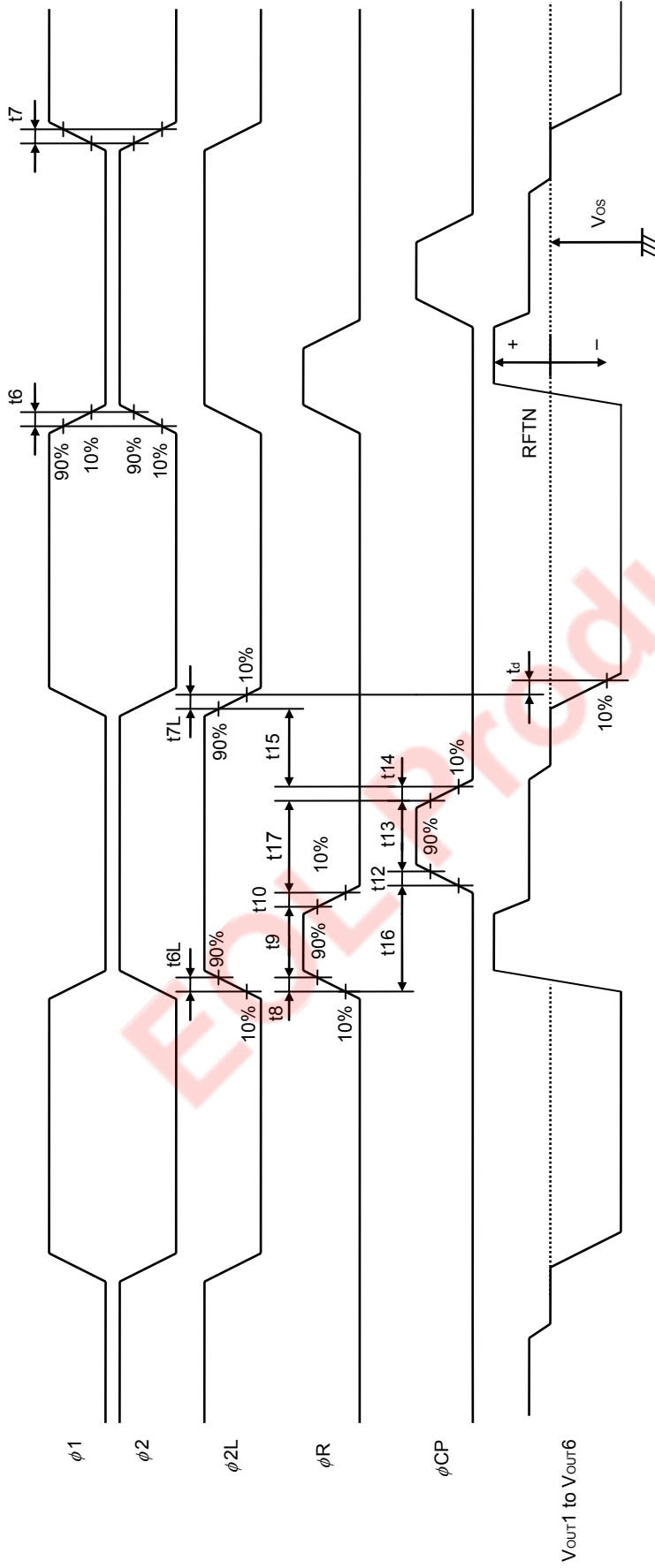

Caution "10%" and "90%" define as the clock voltage with 5 V_{p-p} condition. i.e. "10%" shows 0.5 V, "90%" shows 4.5 V

TIMING CHART 3 (Line Clamp Mode)

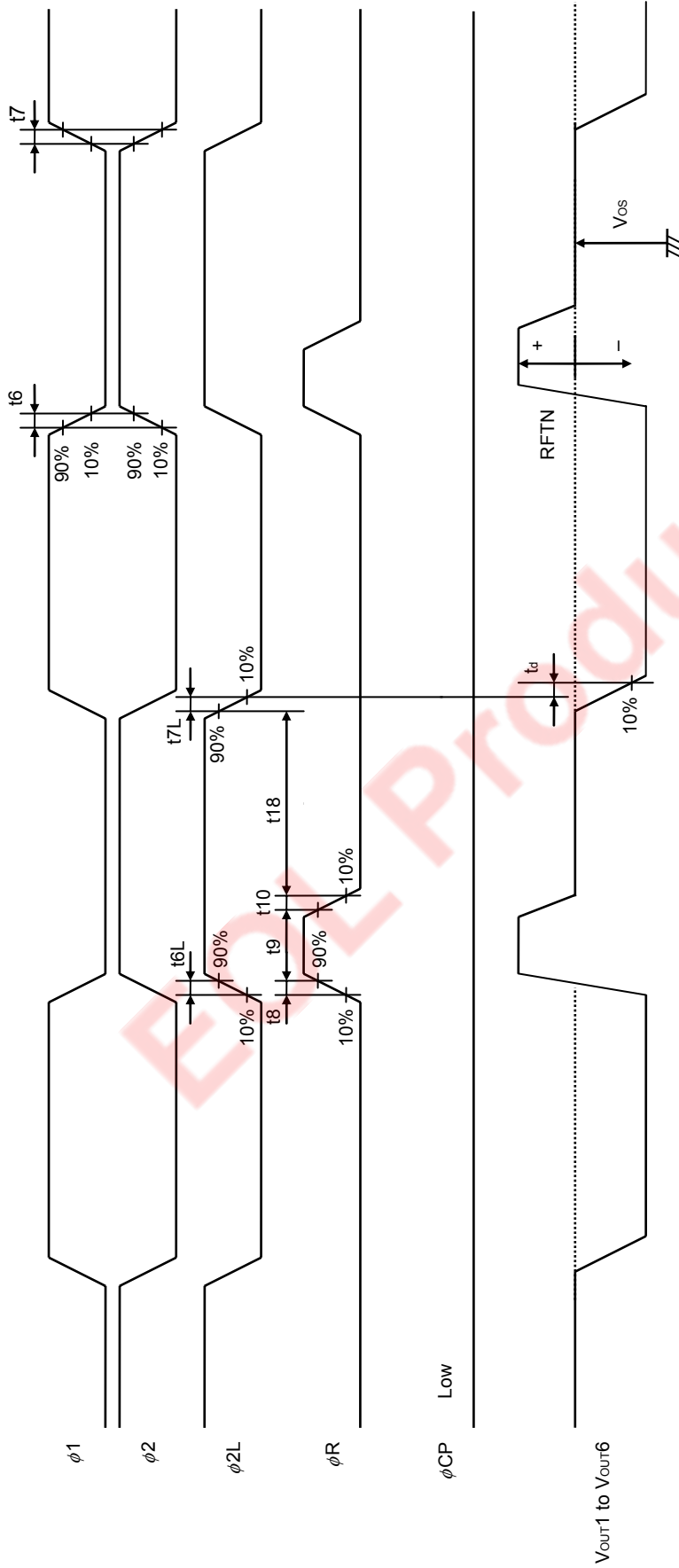

Caution "10%" and "90%" define as the clock voltage with 5 V_{p-p} condition. i.e. "10%" shows 0.5 V, "90%" shows 4.5 V

TIMING CHART 4 (Bit Clamp Mode, Line Clamp Mode)

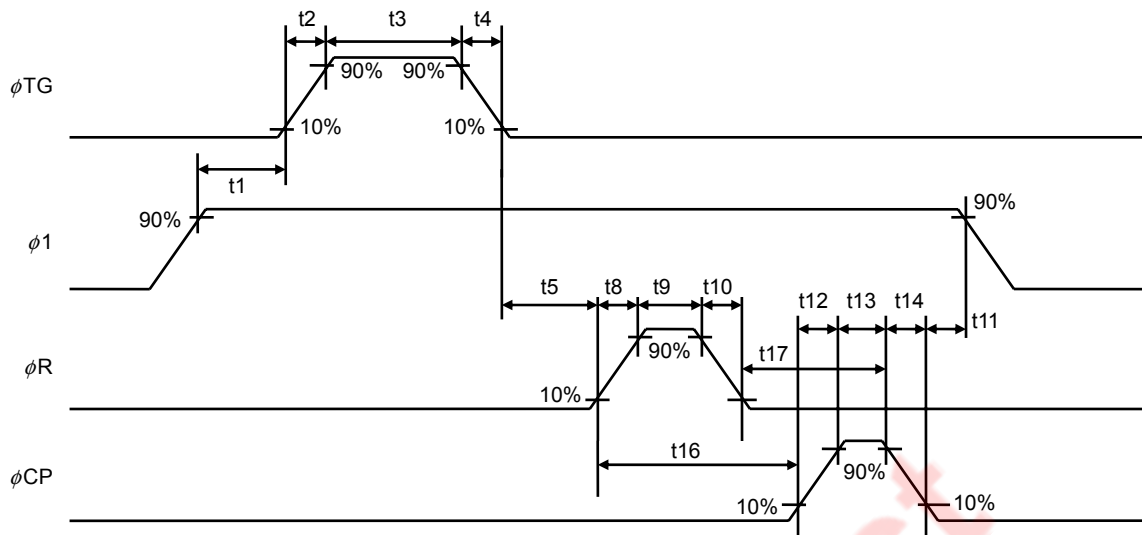

Caution "10%" and "90%" define as the clock voltage with 5 V_{p-p} condition. i.e. "10%" shows 0.5 V, "90%" shows 4.5 V

Symbol	MIN.	TYP.	MAX.	Unit
t1, t5	100	200	2000	ns
t2, t4	0	10	—	ns
t3	500	1000	10000	ns
t6, t7	0	10	—	ns
t6L, t7L	0	3	—	ns
t8, t10	0	3	—	ns
t9	10	125	—	ns
t11	0	250	—	ns
t12, t14	0	3	—	ns
t13	10	125	—	ns
t15	0	250	—	ns
t16	0	125	—	ns
t17	8	125	—	ns
t18	5	125	—	ns

Cross Points Characteristics

φ1, φ2 Cross Points

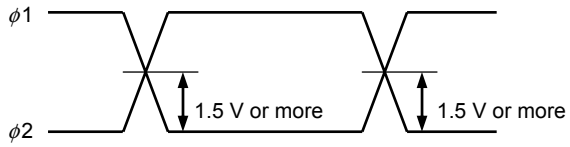

φ1, φ2L Cross Points

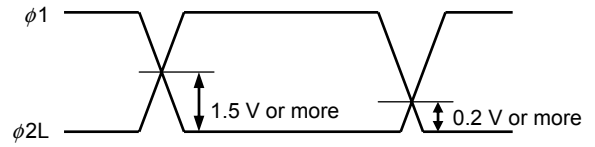

Remark Adjust cross points of (φ1, φ2) and (φ1, φ2L) with input resistance of each pin.

Clock High/Low Level Width Characteristics

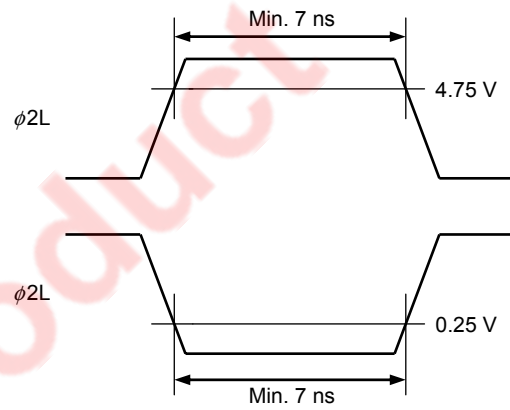
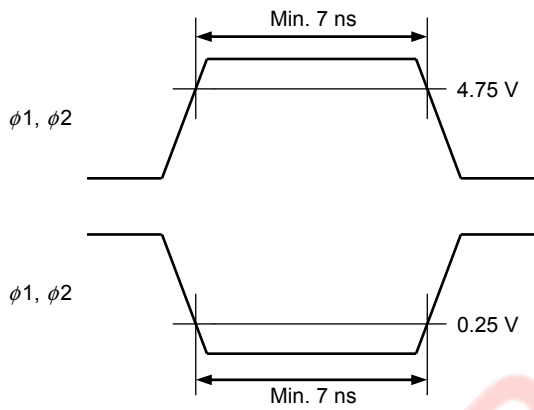

EOL Product

DEFINITIONS OF CHARACTERISTIC ITEMS

1. Saturation voltage : V_{sat}

Output signal voltage at which the response linearity is lost.

2. Saturation exposure : SE

Product of intensity of illumination (lx) and storage time (s) when saturation of output voltage occurs.

3. Photo response non-uniformity : $PRNU$

The output signal non-uniformity of all the valid pixels when the photosensitive surface is applied with the light of uniform illumination. This is calculated by the following formula.

$$PRNU (\%) = \frac{\Delta x}{\bar{x}} \times 100$$

Δx : maximum of $|x_j - \bar{x}|$

$$\bar{x} = \frac{\sum_{j=1}^{3750} x_j}{3750}$$

x_j : Output voltage of valid pixel number j

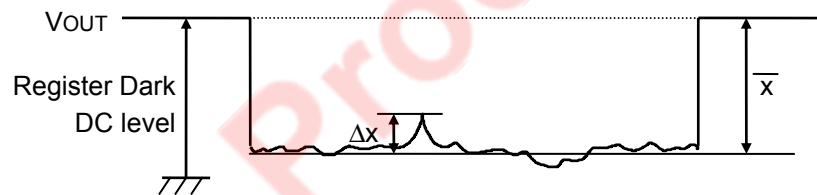

4. Average dark signal : ADS

Average output signal voltage of all the valid pixels at light shielding. This is calculated by the following formula.

$$ADS (mV) = \frac{\sum_{j=1}^{3750} d_j}{3750}$$

d_j : Dark signal of valid pixel number j

5. Dark signal non-uniformity : DSNU

Absolute maximum of the difference between ADS and voltage of the highest or lowest output pixel of all the valid pixels at light shielding. This is calculated by the following formula, and it is defined by each six of them.

DSNU (mV) : maximum of $|d_j - ADS|$ $|j = 1 \text{ to } 3750$

d_j : Dark signal of valid pixel number j

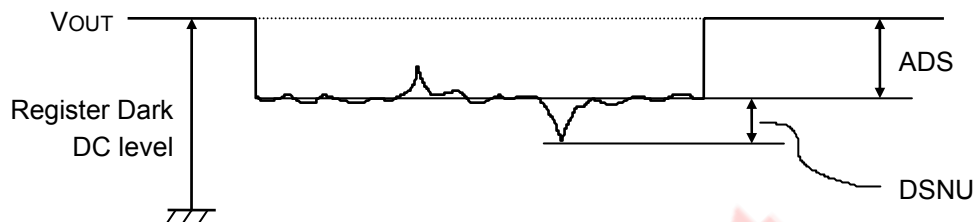

6. Output impedance : Zo

Impedance of the output pins viewed from outside.

7. Response : R

Output voltage divided by exposure ($I \times s$).

Note that the response varies with a light source (spectral characteristic).

8. Image lag : IL

The rate between the last output voltage and the next one after read out the data of a line.

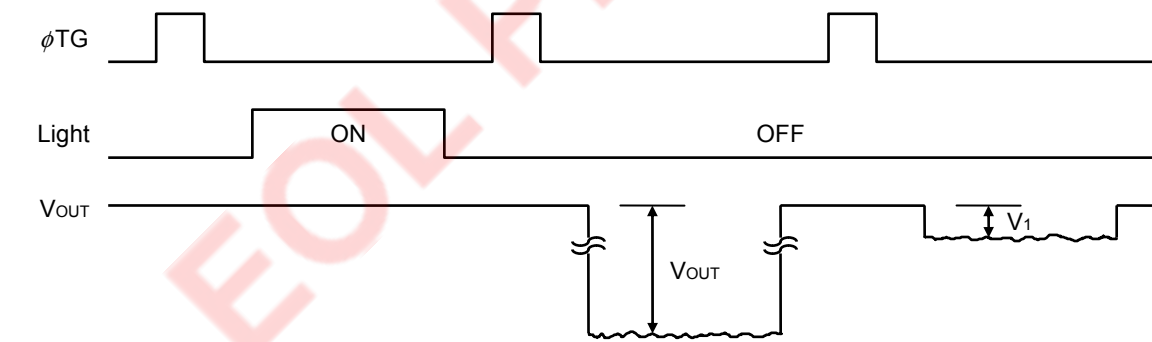

$$IL (\%) = V_1 / V_{OUT} \times 100$$

9. Register imbalance : RI

The rate of the difference between the averages of the output voltage of Odd and Even pixels, against the average output voltage of all the valid pixels.

$$RI (\%) = \frac{\frac{2}{n} \left| \sum_{j=1}^{\frac{n}{2}} (V_{2j-1} - V_{2j}) \right|}{\frac{1}{n} \sum_{j=1}^n V_j} \times 100$$

n : Number of valid pixels

V_j : Output voltage of each pixel

10. Light shielding random noise : σ_{dark}

Light shielding random noise σ_{dark} is defined as the standard deviation of a valid pixel output signal with 100 times (= 100 lines) data sampling at dark (light shielding).

$$\sigma \text{ (mV)} = \sqrt{\frac{\sum_{i=1}^{100} (V_i - \bar{V})^2}{100}}, \quad \bar{V} = \frac{1}{100} \sum_{i=1}^{100} V_i$$

V_i : A valid pixel output signal among all of the valid pixels for each color.

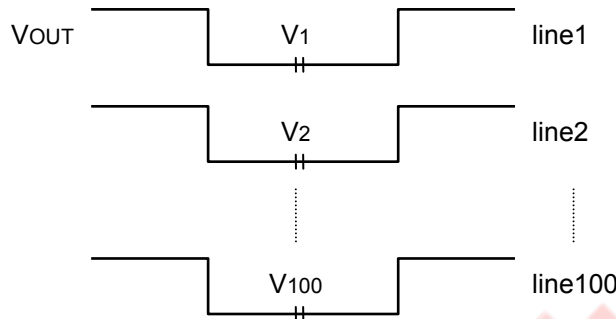

This is measured by the DC level sampling of only the signal level, not by CDS (Correlated Double Sampling)

11. Total transfer efficiently : TTE

The total transfer rate of CCD analog shift register. This is calculated by the following formula, it is defined by each odd output.

$$\text{TTE(\%)} = (1 - V_b / \text{average output of all the valid pixels}) \times 100$$

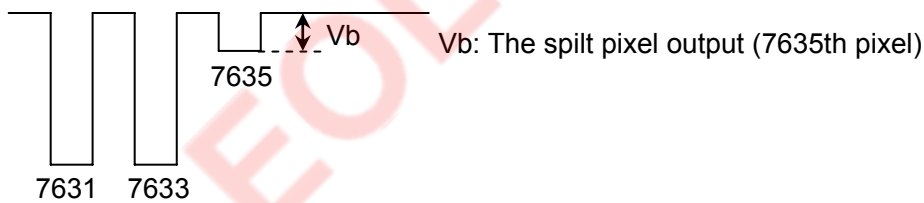

STANDARD CHARACTERISTIC CURVES (Reference Value)

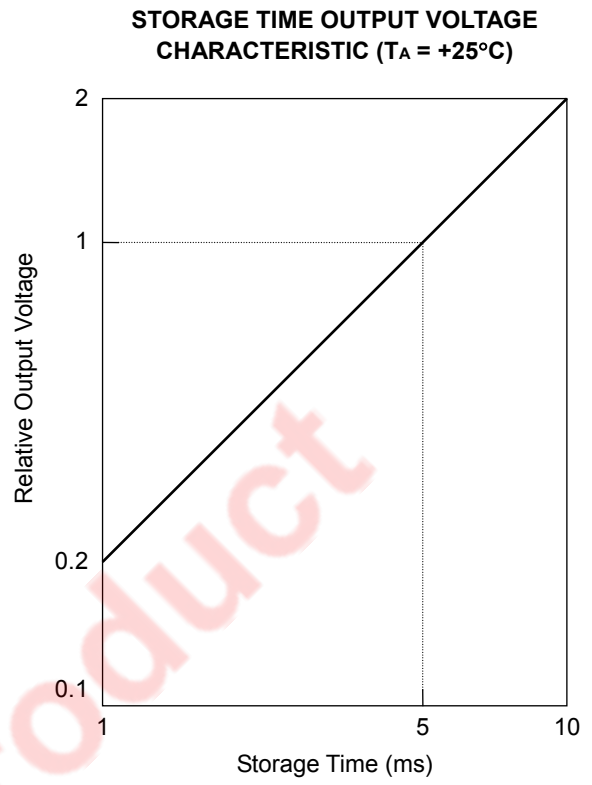
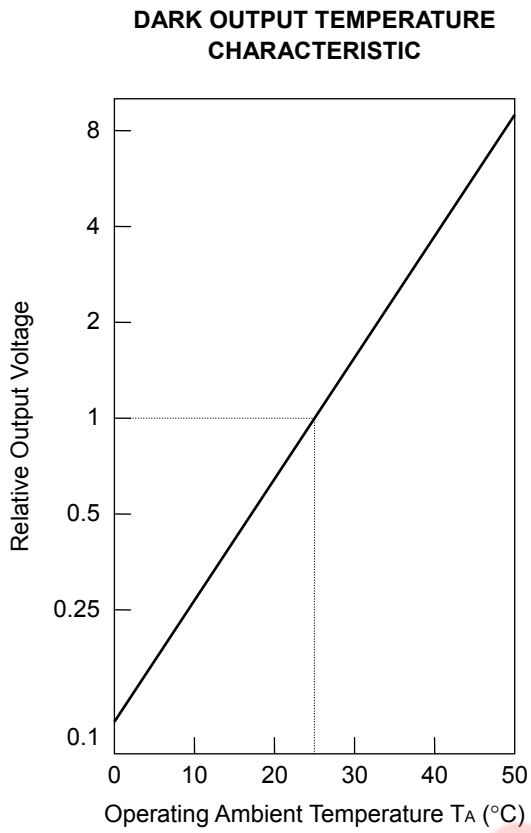

TOTAL SPECTRAL RESPONSE CHARACTERISTICS
(without infrared cut filter and heat absorbing filter) ($T_A = 25^\circ\text{C}$)

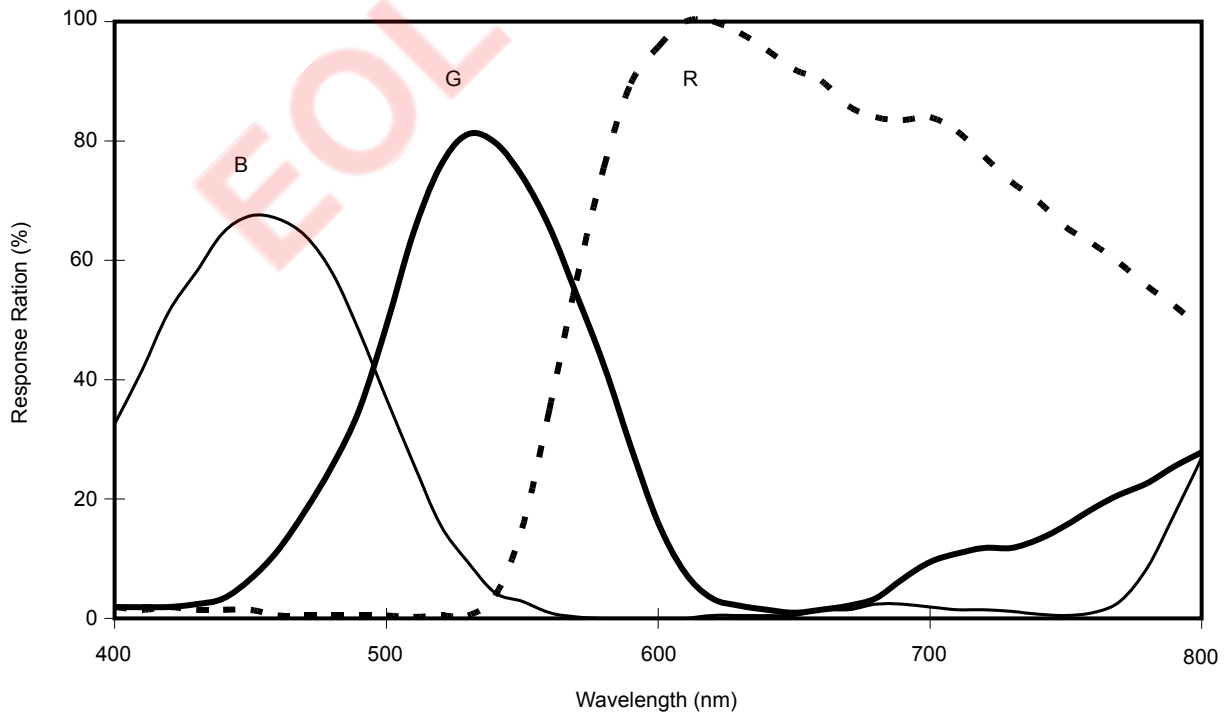

APPLICATION CIRCUIT EXAMPLE

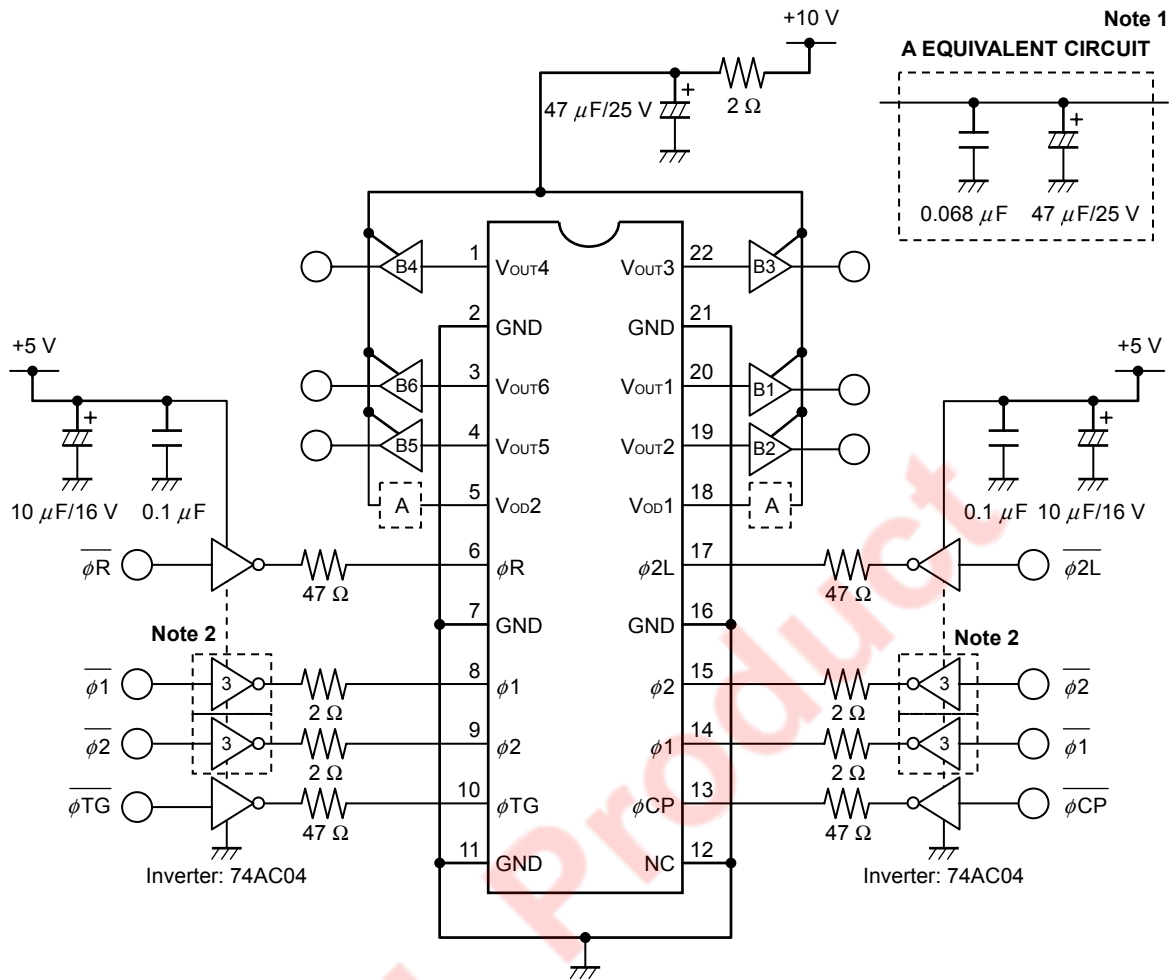

- Notes 1.** Arrange the circuit A near each power supply terminal (V_{OD1} , V_{OD2}) to prevent the interference between V_{OD1} and V_{OD2} .
- 2.** Connects the 3 inverters for each $\phi 1$ and $\phi 2$ pin.

Caution Connect the No connection pins (NC) to GND.

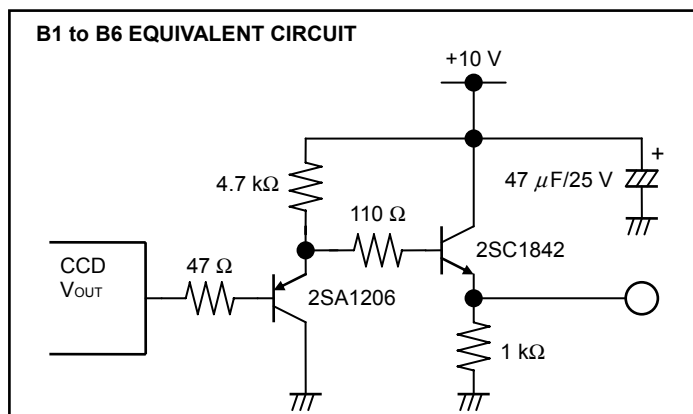

PACKAGE DRAWING

μ PD8828AD-A
 CCD LINEAR IMAGE SENSOR 22-PIN CERAMIC DIP (CERDIP) (10.16 mm (400))

(Unit : mm)

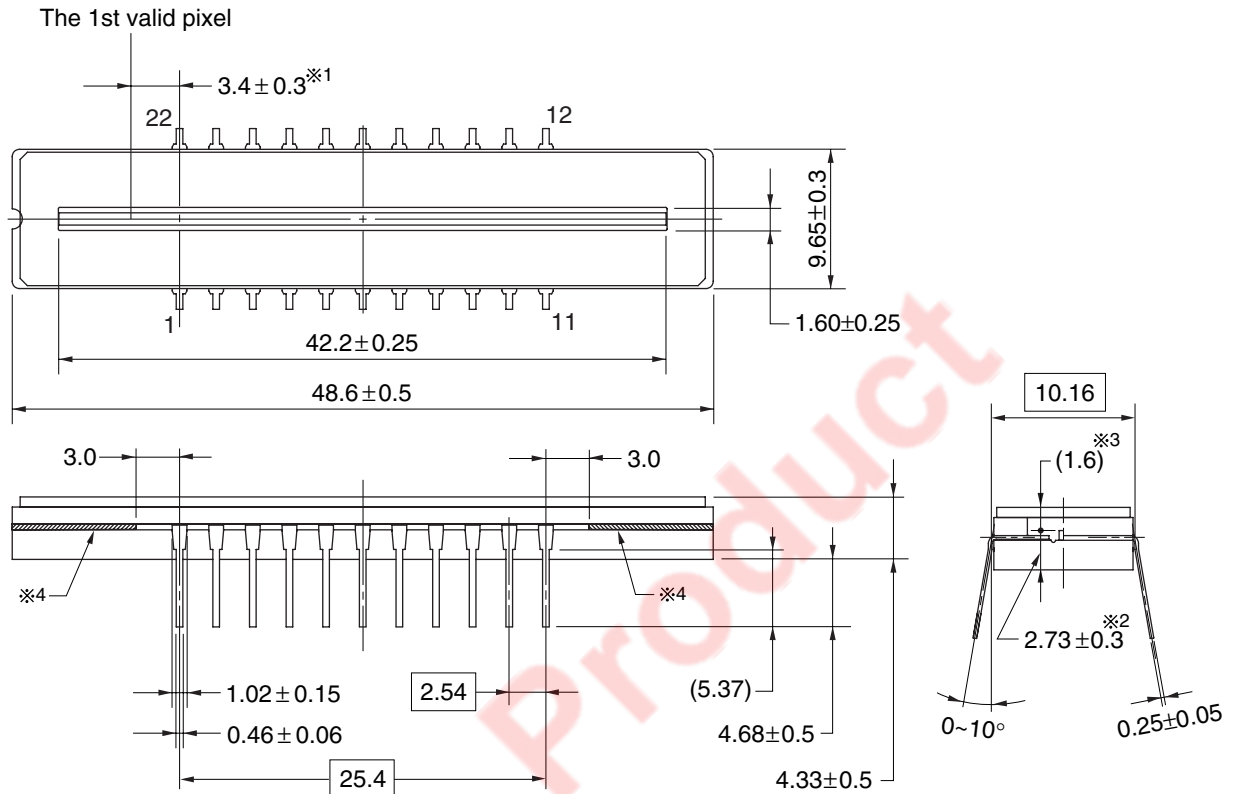

Name	Dimensions	Refractive index
Glass cap	47.5×9.25×0.7	1.5

- ※1 1st valid pixel ↔ Center of pin 1
- ※2 Photosensitive surface of CCD chip ↔ Bottom of package
- ※3 Photosensitive surface of CCD chip ↔ Top of glass cap
- ※4 The shaded portions are overflow prohibited area of the seal glass.

RECOMMENDED SOLDERING CONDITIONS

When soldering this product, it is highly recommended to observe the conditions as shown below.

If other soldering processes are used, or if the soldering is performed under different conditions, please make sure to consult with our sales offices.

Type of Through-hole Device

μPD8828AD-A: CCD linear image sensor 22-pin ceramic DIP (CERDIP) (10.16 mm (400))

Process	Conditions
Partial heating method	Pin temperature: 380°C or below, Heat time: 3 seconds or less (per pin).

- Cautions**
1. **During assembly care should be taken to prevent solder or flux from contacting the glass cap. The optical characteristics could be degraded by such contact.**
 2. **Soldering by the solder flow method may have deleterious effects on prevention of glass cap soiling and heat resistance. So the method cannot be guaranteed.**

EOL Product

NOTES ON HANDLING THE PACKAGES

① MOUNTING OF THE PACKAGE

The application of an excessive load to the package may cause the package to warp or break, or cause chips to come off internally. Particular care should be taken when mounting the package on the circuit board. Don't have any object come in contact with glass cap. You should not reform the lead frame. We recommended to use a IC-inserter when you assemble to PCB.

Also, be care that the any of the following can cause the package to crack or dust to be generated.

1. Applying heat to the external leads for an extended period of time with soldering iron.
2. Applying repetitive bending stress to the external leads.
3. Rapid cooling or heating

② GLASS CAP

Don't either touch glass cap surface by hand or have any object come in contact with glass cap surface. Care should be taken to avoid mechanical or thermal shock because the glass cap is easily to damage. For dirt stuck through electricity ionized air is recommended.

③ OPERATE AND STORAGE ENVIRONMENTS

Operate in clean environments. CCD image sensors are precise optical equipment that should not be subject to mechanical shocks. Exposure to high temperatures or humidity will affect the characteristics. So avoid storage or usage in such conditions.

Keep in a case to protect from dust and dirt. Dew condensation may occur on CCD image sensors when the devices are transported from a low-temperature environment to a high-temperature environment. Avoid such rapid temperature changes.

For more details, refer to our document "Review of Quality and Reliability Handbook" (C12769E)

④ ELECTROSTATIC BREAKDOWN

CCD image sensor is protected against static electricity, but destruction due to static electricity is sometimes detected. Before handling be sure to take the following protective measures.

1. Ground the tools such as soldering iron, radio cutting pliers or of pincer.
2. Install a conductive mat or on the floor or working table to prevent the generation of static electricity.
3. Either handle bare handed or use non-chargeable gloves, clothes or material.
4. Ionized air is recommended for discharge when handling CCD image sensor.
5. For the shipment of mounted substrates, use box treated for prevention of static charges.
6. Anyone who is handling CCD image sensors, mounting them on PCBs or testing or inspecting PCBs on which CCD image sensors have been mounted must wear anti-static bands such as wrist straps and ankle straps which are grounded via a series resistance connection of about 1 MΩ.

[MEMO]

EOL Product

[MEMO]

EOL Product

[MEMO]

EOL Product

NOTES FOR CMOS DEVICES

① VOLTAGE APPLICATION WAVEFORM AT INPUT PIN

Waveform distortion due to input noise or a reflected wave may cause malfunction. If the input of the CMOS device stays in the area between V_{IL} (MAX) and V_{IH} (MIN) due to noise, etc., the device may malfunction. Take care to prevent chattering noise from entering the device when the input level is fixed, and also in the transition period when the input level passes through the area between V_{IL} (MAX) and V_{IH} (MIN).

② HANDLING OF UNUSED INPUT PINS

Unconnected CMOS device inputs can be cause of malfunction. If an input pin is unconnected, it is possible that an internal input level may be generated due to noise, etc., causing malfunction. CMOS devices behave differently than Bipolar or NMOS devices. Input levels of CMOS devices must be fixed high or low by using pull-up or pull-down circuitry. Each unused pin should be connected to V_{DD} or GND via a resistor if there is a possibility that it will be an output pin. All handling related to unused pins must be judged separately for each device and according to related specifications governing the device.

③ PRECAUTION AGAINST ESD

A strong electric field, when exposed to a MOS device, can cause destruction of the gate oxide and ultimately degrade the device operation. Steps must be taken to stop generation of static electricity as much as possible, and quickly dissipate it when it has occurred. Environmental control must be adequate. When it is dry, a humidifier should be used. It is recommended to avoid using insulators that easily build up static electricity. Semiconductor devices must be stored and transported in an anti-static container, static shielding bag or conductive material. All test and measurement tools including work benches and floors should be grounded. The operator should be grounded using a wrist strap. Semiconductor devices must not be touched with bare hands. Similar precautions need to be taken for PW boards with mounted semiconductor devices.

④ STATUS BEFORE INITIALIZATION

Power-on does not necessarily define the initial status of a MOS device. Immediately after the power source is turned ON, devices with reset functions have not yet been initialized. Hence, power-on does not guarantee output pin levels, I/O settings or contents of registers. A device is not initialized until the reset signal is received. A reset operation must be executed immediately after power-on for devices with reset functions.

⑤ POWER ON/OFF SEQUENCE

In the case of a device that uses different power supplies for the internal operation and external interface, as a rule, switch on the external power supply after switching on the internal power supply. When switching the power supply off, as a rule, switch off the external power supply and then the internal power supply. Use of the reverse power on/off sequences may result in the application of an overvoltage to the internal elements of the device, causing malfunction and degradation of internal elements due to the passage of an abnormal current.

The correct power on/off sequence must be judged separately for each device and according to related specifications governing the device.

⑥ INPUT OF SIGNAL DURING POWER OFF STATE

Do not input signals or an I/O pull-up power supply while the device is not powered. The current injection that results from input of such a signal or I/O pull-up power supply may cause malfunction and the abnormal current that passes in the device at this time may cause degradation of internal elements.

Input of signals during the power off state must be judged separately for each device and according to related specifications governing the device.

- **The information in this document is current as of October, 2006. The information is subject to change without notice. For actual design-in, refer to the latest publications of NEC Electronics data sheets or data books, etc., for the most up-to-date specifications of NEC Electronics products. Not all products and/or types are available in every country. Please check with an NEC Electronics sales representative for availability and additional information.**
- No part of this document may be copied or reproduced in any form or by any means without the prior written consent of NEC Electronics. NEC Electronics assumes no responsibility for any errors that may appear in this document.
- NEC Electronics does not assume any liability for infringement of patents, copyrights or other intellectual property rights of third parties by or arising from the use of NEC Electronics products listed in this document or any other liability arising from the use of such products. No license, express, implied or otherwise, is granted under any patents, copyrights or other intellectual property rights of NEC Electronics or others.
- Descriptions of circuits, software and other related information in this document are provided for illustrative purposes in semiconductor product operation and application examples. The incorporation of these circuits, software and information in the design of a customer's equipment shall be done under the full responsibility of the customer. NEC Electronics assumes no responsibility for any losses incurred by customers or third parties arising from the use of these circuits, software and information.
- While NEC Electronics endeavors to enhance the quality, reliability and safety of NEC Electronics products, customers agree and acknowledge that the possibility of defects thereof cannot be eliminated entirely. To minimize risks of damage to property or injury (including death) to persons arising from defects in NEC Electronics products, customers must incorporate sufficient safety measures in their design, such as redundancy, fire-containment and anti-failure features.
- NEC Electronics products are classified into the following three quality grades: "Standard", "Special" and "Specific".

The "Specific" quality grade applies only to NEC Electronics products developed based on a customer-designated "quality assurance program" for a specific application. The recommended applications of an NEC Electronics product depend on its quality grade, as indicated below. Customers must check the quality grade of each NEC Electronics product before using it in a particular application.

"Standard": Computers, office equipment, communications equipment, test and measurement equipment, audio and visual equipment, home electronic appliances, machine tools, personal electronic equipment and industrial robots.

"Special": Transportation equipment (automobiles, trains, ships, etc.), traffic control systems, anti-disaster systems, anti-crime systems, safety equipment and medical equipment (not specifically designed for life support).

"Specific": Aircraft, aerospace equipment, submersible repeaters, nuclear reactor control systems, life support systems and medical equipment for life support, etc.

The quality grade of NEC Electronics products is "Standard" unless otherwise expressly specified in NEC Electronics data sheets or data books, etc. If customers wish to use NEC Electronics products in applications not intended by NEC Electronics, they must contact an NEC Electronics sales representative in advance to determine NEC Electronics' willingness to support a given application.

(Note)

- (1) "NEC Electronics" as used in this statement means NEC Electronics Corporation and also includes its majority-owned subsidiaries.
- (2) "NEC Electronics products" means any product developed or manufactured by or for NEC Electronics (as defined above).