

National Semiconductor is now part of
Texas Instruments.

Search <http://www.ti.com/> for the latest technical
information and details on our current products and services.

LMH6738

Very Wideband, Low Distortion Triple Op Amp

General Description

The LMH6738 is a very wideband, DC coupled monolithic operational amplifier designed specifically for ultra high resolution video systems as well as wide dynamic range systems requiring exceptional signal fidelity. Benefiting from National's current feedback architecture, the LMH6738 offers a gain range of ± 1 to ± 10 while providing stable, operation without external compensation, even at unity gain. At a gain of +2 the LMH6738 supports ultra high resolution video systems with a 400 MHz $2 V_{PP}$ -3 dB Bandwidth. With 12-bit distortion levels through 30 MHz ($R_L = 100\Omega$), 2.3 nV/ $\sqrt{\text{Hz}}$ Hz input referred noise, the LMH6738 is the ideal driver or buffer for high speed flash A/D and D/A converters. Wide dynamic range systems such as radar and communication receivers requiring a wideband amplifier offering exceptional signal purity will find the LMH6738's low input referred noise and low harmonic distortion make it an attractive solution.

Features

- 750 MHz -3 dB small signal bandwidth ($A_V = +1$)
- -85 dBc 3rd harmonic distortion (20 MHz)
- 2.3 nV/ $\sqrt{\text{Hz}}$ Hz input noise voltage
- 3300 V/ μs slew rate
- 33 mA supply current (11.3 mA per op amp)
- 90 mA linear output current
- 0.02/0.01 Diff. Gain / Diff. Phase ($R_L = 150\Omega$)

Applications

- RGB video driver
- High resolution projectors
- Flash A/D driver
- D/A transimpedance buffer
- Wide dynamic range IF amp
- Radar/communication receivers
- DDS post-amps
- Wideband inverting summer
- Line driver

Connection Diagram

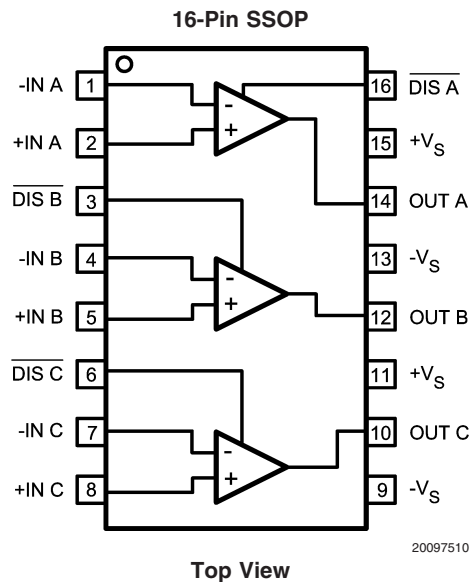

VIP10™ is a trademark of National Semiconductor Corporation.

Absolute Maximum Ratings (Note 1)

If Military/Aerospace specified devices are required, please contact the National Semiconductor Sales Office/Distributors for availability and specifications.

Supply Voltage ($V^+ - V^-$)	13.2V
I_{OUT}	(Note 3)
Common Mode Input Voltage	$\pm V_{CC}$
Maximum Junction Temperature	+150°C
Storage Temperature Range	-65°C to +150°C
Soldering Information	
Infrared or Convection (20 sec.)	235°C
Wave Soldering (10 sec.)	260°C

ESD Tolerance (Note 4)

Human Body Model	2000V
Machine Model	200V
Storage Temperature Range	-65°C to +150°C

Operating Ratings (Note 1)

Thermal Resistance		
Package	(θ_{JC})	(θ_{JA})
16-Pin SSOP	36°C/W	120°C/W
Operating Temperature Range	-40°C	+85°C
Supply Voltage ($V^+ - V^-$)	8V	to 12V

Electrical Characteristics (Note 2)

$A_V = +2$, $V_{CC} = \pm 5V$, $R_L = 100\Omega$, $R_F = 549\Omega$; unless otherwise specified.

Symbol	Parameter	Conditions	Min	Typ	Max	Units
Frequency Domain Performance						
UGBW	-3 dB Bandwidth	Unity Gain, $V_{OUT} = 200 \text{ mV}_{PP}$		750		MHz
SSBW	-3 dB Bandwidth	$V_{OUT} = 200 \text{ mV}_{PP}$		480		MHz
LSBW		$V_{OUT} = 2 V_{PP}$		400		
	0.1 dB Bandwidth	$V_{OUT} = 2 V_{PP}$		150		MHz
GFPL	Peaking	DC to 75 MHz		0		dB
GFR1	Rolloff	DC to 150 MHz, $V_{OUT} = 2 V_{PP}$		0.1		dB
GFR2	Rolloff	@ 300 MHz, $V_{OUT} = 2 V_{PP}$		1.0		dB
Time Domain Response						
TRS	Rise and Fall Time (10% to 90%)	2V Step		0.9		ns
TRL		5V Step		1.7		
SR	Slew Rate	5V Step		3300		V/ μ s
t_s	Settling Time to 0.1%	2V Step		10		ns
t_e	Enable Time	From $\overline{\text{Disable}}$ = rising edge.		7.3		ns
t_d	Disable Time	From $\overline{\text{Disable}}$ = falling edge.		4.5		ns
Distortion						
HD2L	2 nd Harmonic Distortion	2 V_{PP} , 5 MHz		-80		dBc
HD2		2 V_{PP} , 20 MHz		-71		
HD2H		2 V_{PP} , 50 MHz		-55		
HD3L	3 rd Harmonic Distortion	2 V_{PP} , 5 MHz		-90		dBc
HD3		2 V_{PP} , 20 MHz		-85		
HD3H		2 V_{PP} , 50 MHz		-65		
Equivalent Input Noise						
V_N	Non-Inverting Voltage	>1 MHz		2.3		nV/ $\sqrt{\text{Hz}}$
I_{CN}	Inverting Current	>1 MHz		12		pA/ $\sqrt{\text{Hz}}$
N_{CN}	Non-Inverting Current	>1 MHz		3		pA/ $\sqrt{\text{Hz}}$
Video Performance						
DG	Differential Gain	4.43 MHz, $R_L = 150\Omega$.02		%
DP	Differential Phase	4.43 MHz, $R_L = 150\Omega$.01		°
Static, DC Performance						
VIO	Input Offset Voltage (Note 6)			0.5	± 2.5 ± 4.5	mV
IBN	Input Bias Current (Note 6)	Non-Inverting	-15 -20	-7	0 +5	μ A
IBI	Input Bias Current (Note 6)	Inverting		-2	± 25 ± 35	μ A

Electrical Characteristics (Note 2) (Continued)
 $A_V = +2$, $V_{CC} = \pm 5V$, $R_L = 100\Omega$, $R_F = 549\Omega$; unless otherwise specified.

Symbol	Parameter	Conditions	Min	Typ	Max	Units
PSRR	Power Supply Rejection Ratio (Note 6)		50 48.5	53		dB
CMRR	Common Mode Rejection Ratio (Note 6)		46 44	50		dB
XTLK	Crosstalk	Input Referred, $f=10\text{MHz}$, Drive channels A,C measure channel B		-80		dB
I_{CC}	Supply Current (Note 6)	All three amps Enabled, No Load		32	35 40	mA
	Supply Current Disabled V^+	$R_L = \infty$		1.9	2.2	mA
	Supply Current Disabled V^-	$R_L = \infty$		1.1	1.3	mA

Miscellaneous Performance

R_{IN+}	Non-Inverting Input Resistance			1000		k Ω
C_{IN+}	Non-Inverting Input Capacitance			.8		pF
R_{IN-}	Inverting Input Impedance	Output impedance of input buffer.		30		Ω
R_O	Output Impedance	DC		0.05		Ω
V_O	Output Voltage Range (Note 6)	$R_L = 100\Omega$	± 3.25 ± 3.1	± 3.5		V
		$R_L = \infty$	± 3.65 ± 3.5	± 3.8		
CMIR	Common Mode Input Range (Note 6)	CMRR > 40 dB	± 1.9 ± 1.7	± 2.0		V
I_O	Linear Output Current (Notes 3, 6)	$V_{IN} = 0V$, $V_{OUT} < \pm 30\text{ mV}$	80 60	90		mA
I_{SC}	Short Circuit Current (Note 5)	$V_{IN} = 2V$ Output Shorted to Ground		160		mA
I_{IH}	Disable Pin Bias Current High	Disable Pin = V^+		10		μA
I_{IL}	Disable Pin Bias Current Low	Disable Pin = $0V$		-350		μA
V_{DMAX}	Voltage for Disable	Disable Pin $\leq V_{DMAX}$			0.8	V
V_{DMIM}	Voltage for Enable	Disable Pin $\geq V_{DMIN}$	2.0			V

Note 1: Absolute Maximum Ratings indicate limits beyond which damage to the device may occur. Operating Ratings indicate conditions for which the device is intended to be functional, but specific performance is not guaranteed. For guaranteed specifications, see the Electrical Characteristics tables.

Note 2: Electrical Table values apply only for factory testing conditions at the temperature indicated. Factory testing conditions result in very limited self-heating of the device such that $T_J = T_A$. No guarantee of parametric performance is indicated in the electrical tables under conditions of internal self heating where $T_J > T_A$. See Applications Section for information on temperature de-rating of this device." Min/Max ratings are based on product characterization and simulation. Individual parameters are tested as noted.

Note 3: The maximum output current (I_{OUT}) is determined by device power dissipation limitations. See the Power Dissipation section of the Application Section for more details.

Note 4: Human Body Model is 1.5 k Ω in series with 100 pF. Machine Model is 0 Ω in series with 200 pF.

Note 5: Short circuit current should be limited in duration to no more than 10 seconds. See the Power Dissipation section of the Application Section for more details.

Note 6: Parameter 100% production tested at 25° C.

Ordering Information

Package	Part Number	Package Marking	Transport Media	NSC Drawing
16-pin SSOP	LMH6738MQ	LH6738MQ	95 Units/Rail	MQA16
	LMH6738MQX		2.5k Units Tape and Reel	

Typical Performance Characteristics $A_V = +2, V_{CC} = \pm 5V, R_L = 100\Omega, R_F = 549\Omega$; unless otherwise specified).

Large Signal Frequency Response

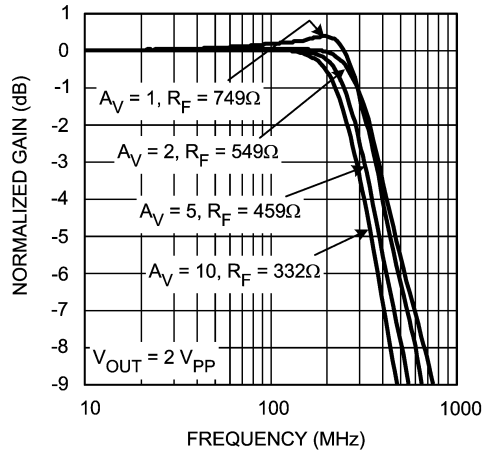

20097520

Large Signal Frequency Response

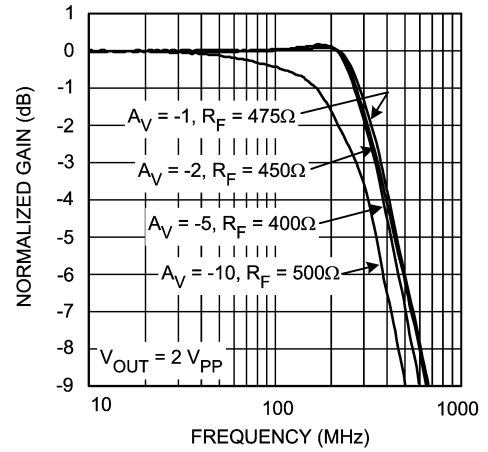

20097528

Small Signal Frequency Response

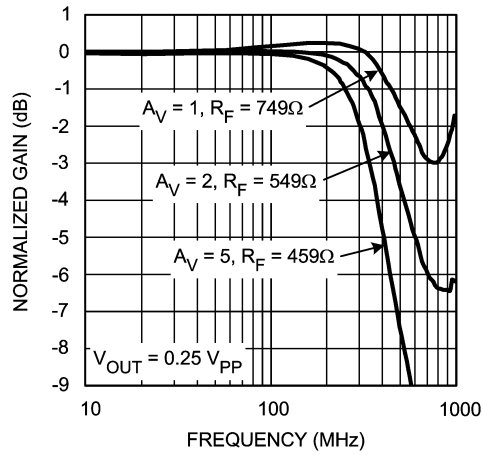

20097513

Frequency Response vs. V_{OUT}

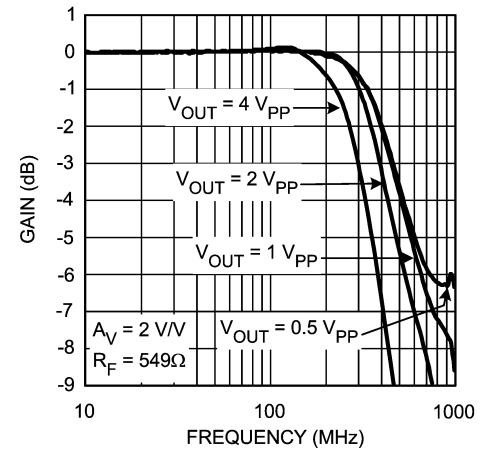

20097501

Frequency Response vs. Supply Voltage

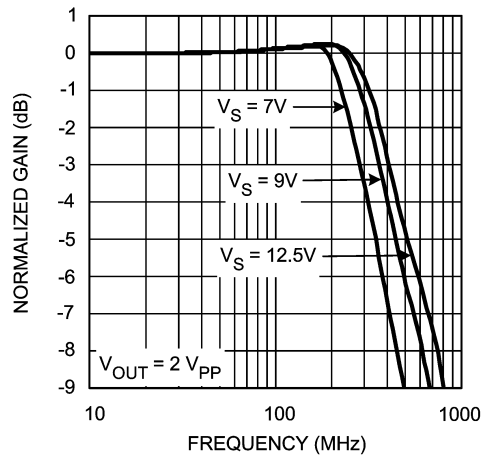

20097516

Gain Flatness

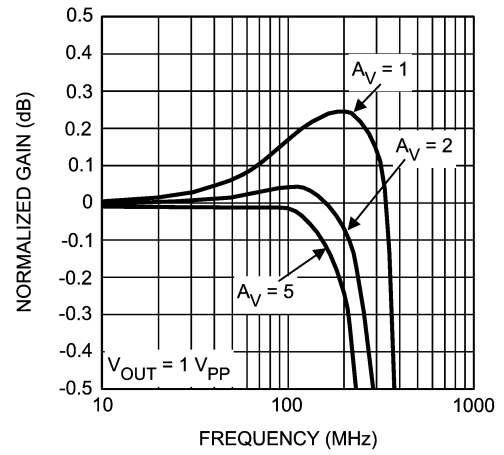

20097530

Typical Performance Characteristics $A_V = +2$, $V_{CC} = \pm 5V$, $R_L = 100\Omega$, $R_F = 549\Omega$; unless otherwise specified). (Continued)

Pulse Response

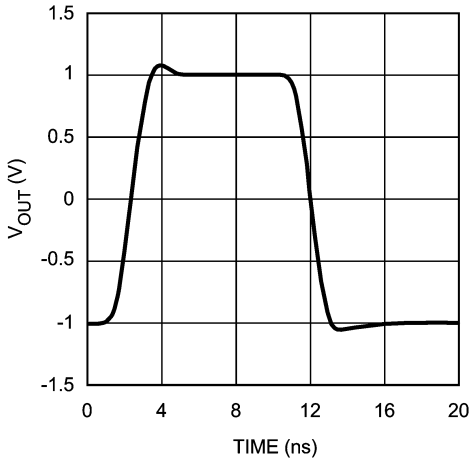

20097522

Frequency Response vs. Capacitive Load

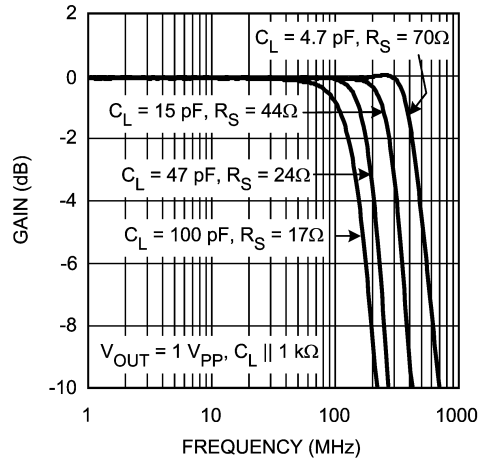

20097514

Series Output Resistance vs. Capacitive Load

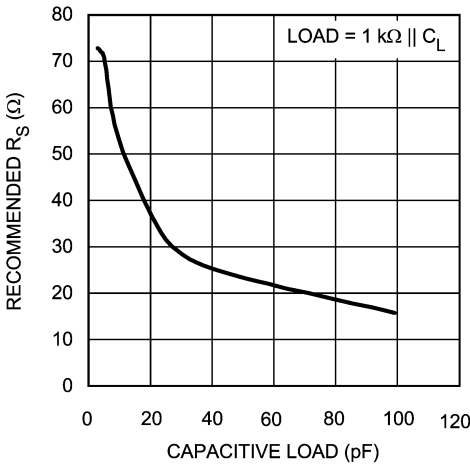

20097519

Open Loop Gain and Phase

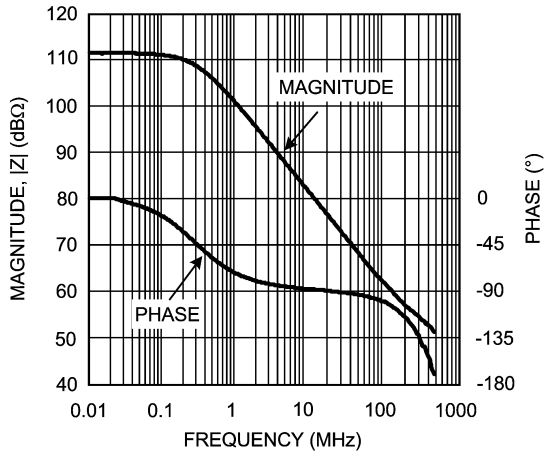

20097526

Distortion vs. Frequency

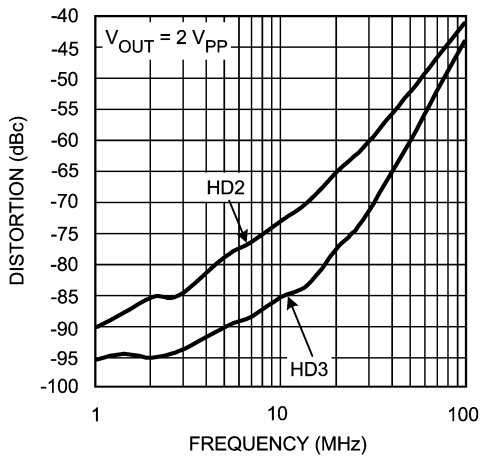

20097525

Distortion vs. Output Voltage

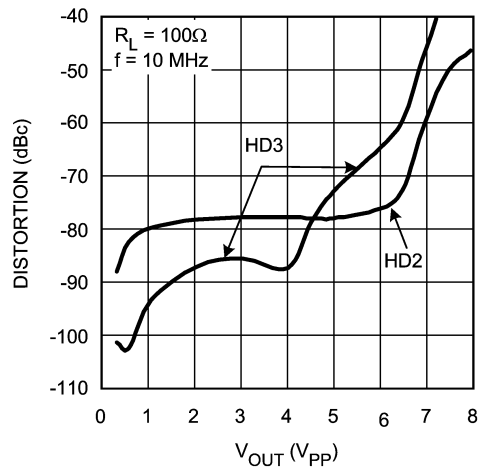

20097517

Typical Performance Characteristics $A_V = +2$, $V_{CC} = \pm 5V$, $R_L = 100\Omega$, $R_F = 549\Omega$; unless otherwise specified). (Continued)

Distortion vs. Supply Voltage

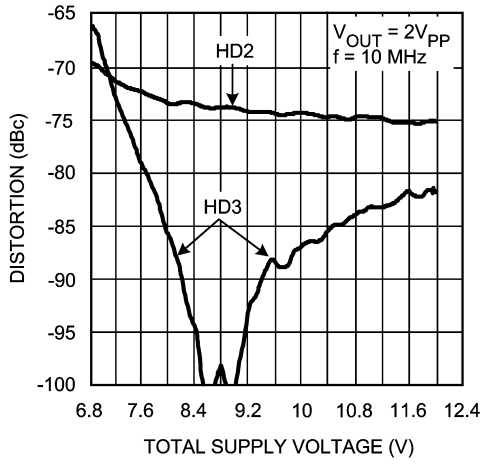

20097518

CMRR vs. Frequency

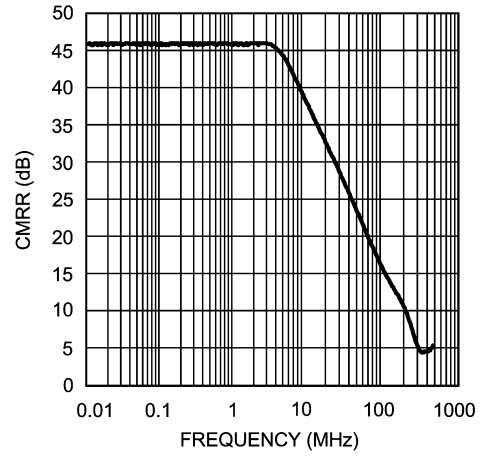

20097511

PSRR vs. Frequency

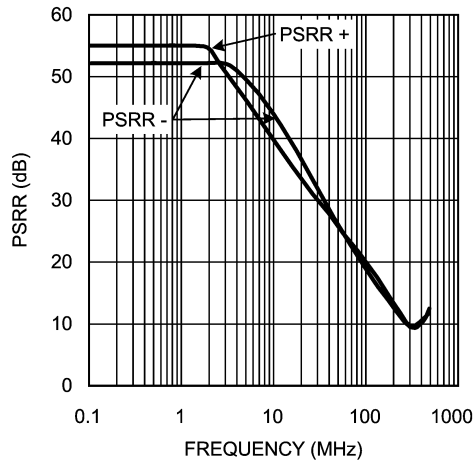

20097521

Crosstalk vs. Frequency

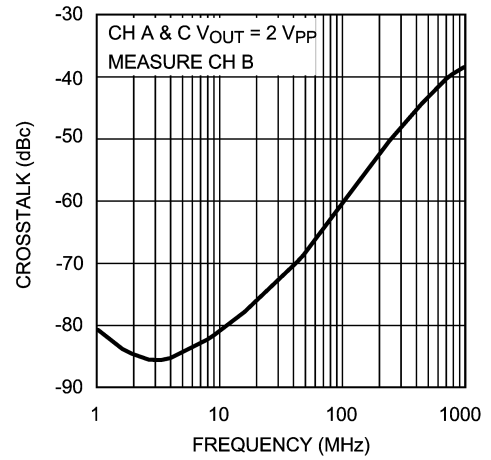

20097529

Closed Loop Output Impedance |Z|

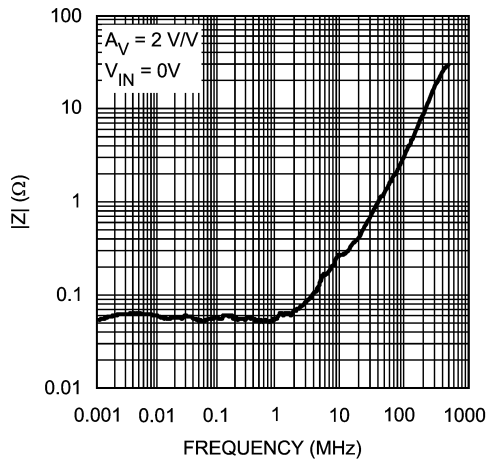

20097504

Disable Timing

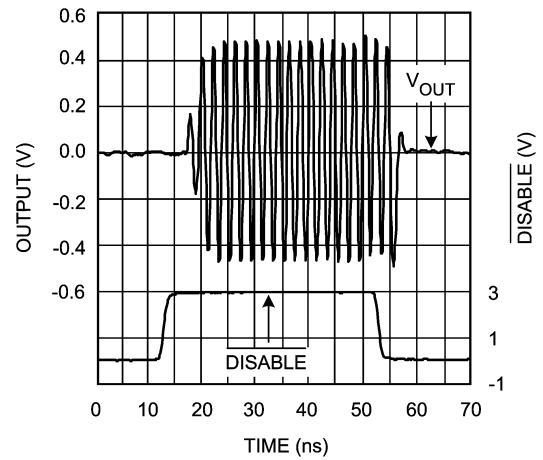

20097524

Typical Performance Characteristics $A_V = +2$, $V_{CC} = \pm 5V$, $R_L = 100\Omega$, $R_F = 549\Omega$; unless otherwise specified). (Continued)

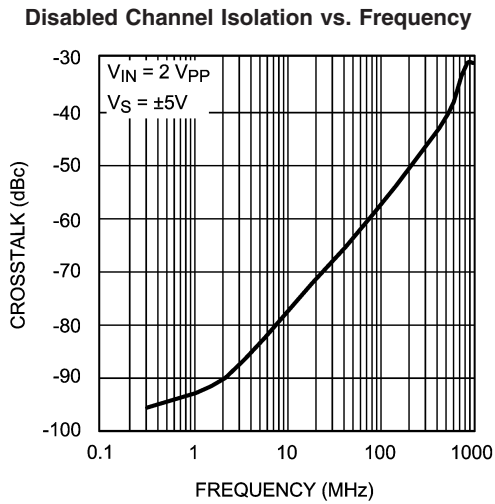
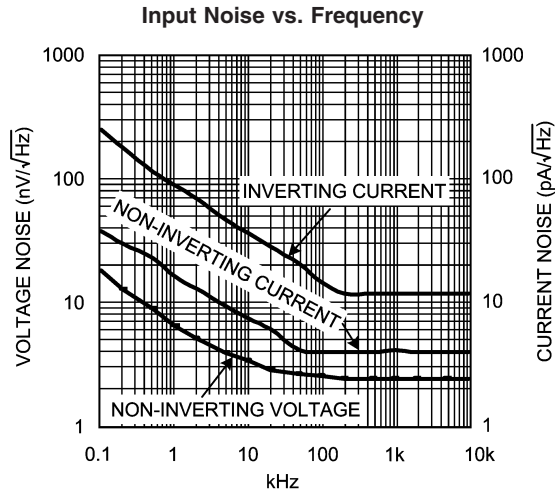
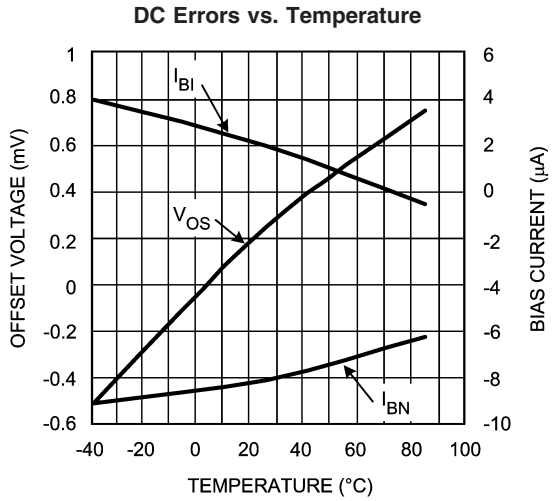

Application Section

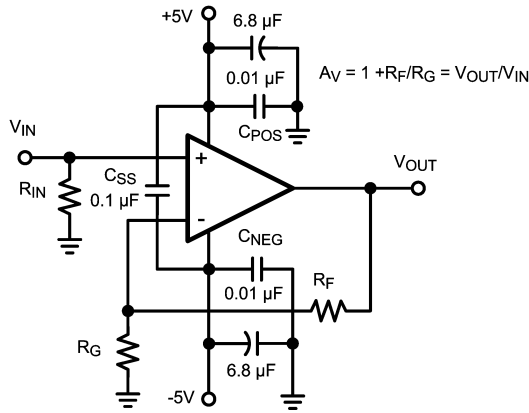

20097505

FIGURE 1. Recommended Non-Inverting Gain Circuit

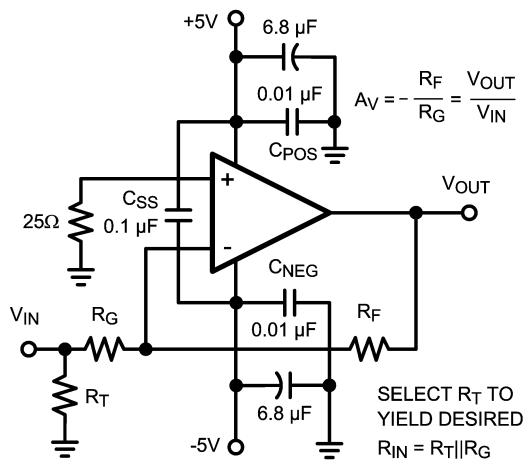

20097506

FIGURE 2. Recommended Inverting Gain Circuit

GENERAL INFORMATION

The LMH6738 is a high speed current feedback amplifier, optimized for very high speed and low distortion. The LMH6738 has no internal ground reference so single or split supply configurations are both equally useful.

EVALUATION BOARDS

National Semiconductor provides the following evaluation boards as a guide for high frequency layout and as an aid in device testing and characterization. Many of the datasheet plots were measured with these boards.

Device	Package	Evaluation Board Part Number
LMH6738MQA	SSOP	LMH730275

A bare evaluation board is shipped when a sample request is placed with National Semiconductor.

FEEDBACK RESISTOR SELECTION

One of the key benefits of a current feedback operational amplifier is the ability to maintain optimum frequency response independent of gain by using appropriate values for the feedback resistor (R_F). The Electrical Characteristics and Typical Performance plots specify an R_F of 550Ω, a gain of +2 V/V and ±5V power supplies (unless otherwise specified). Generally, lowering R_F from its recommended value will peak the frequency response and extend the bandwidth while increasing the value of R_F will cause the frequency response to roll off faster. Reducing the value of R_F too far below its recommended value will cause overshoot, ringing and, eventually, oscillation.

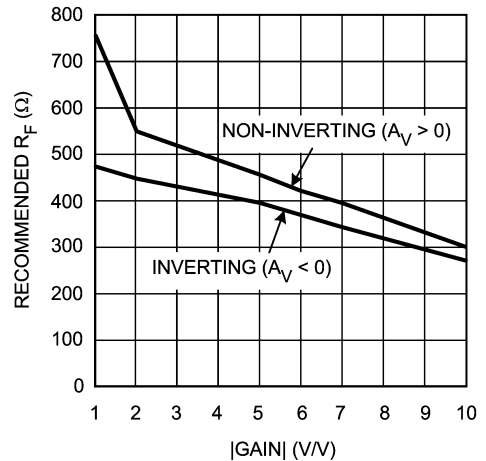

20097503

FIGURE 3. Recommended R_F vs. Gain

See Figure 3, Recommended R_F . vs Gain for selecting a feedback resistor value for gains of ±1 to ±10. Since each application is slightly different it is worth some experimentation to find the optimal R_F for a given circuit. In general a value of R_F that produces ~.1 dB of peaking is the best compromise between stability and maximal bandwidth. Note that it is not possible to use a current feedback amplifier with the output shorted directly to the inverting input. The buffer configuration of the LMH6738 requires a 750Ω feedback resistor for stable operation.

The LMH6738 was optimized for high speed operation. As shown in Figure 3 the suggested value for R_F decreases for higher gains. Due to the impedance of the input buffer there is a practical limit for how small R_F can go, based on the lowest practical value of R_G . This limitation applies to both inverting and non inverting configurations. For the LMH6738 the input resistance of the inverting input is approximately 30Ω and 20Ω is a practical (but not hard and fast) lower limit for R_G . The LMH6738 begins to operate in a gain bandwidth limited fashion in the region where R_G is nearly equal to the input buffer impedance. Note that the amplifier will operate with R_G values well below 20Ω, however results may be substantially different than predicted from ideal models. In particular the voltage potential between the Inverting and Non Inverting inputs cannot be expected to remain small.

Inverting gain applications that require impedance matched inputs may limit gain flexibility somewhat (especially if maximum bandwidth is required). The impedance seen by the source is $R_G \parallel R_T$ (R_T is optional). The value of R_G is R_F

Application Section (Continued)

/Gain. Thus for an inverting gain of -7 V/V and an optimal value for R_F the input impedance is equal to 50Ω . Using a termination resistor this can be brought down to match a 25Ω source, however, a 150Ω source cannot be matched. To match a 150Ω source would require using a 1050Ω feedback resistor and would result in reduced bandwidth.

For more information see Application Note OA-13 which describes the relationship between R_F and closed-loop frequency response for current feedback operational amplifiers. The value for the inverting input impedance for the LMH6738 is approximately 30Ω . The LMH6738 is designed for optimum performance at gains of $+1$ to $+10$ V/V and -1 to -9 V/V. Higher gain configurations are still useful, however, the bandwidth will fall as gain is increased, much like a typical voltage feedback amplifier.

ACTIVE FILTER

When using any current feedback Operational Amplifier as an active filter it is necessary to be careful using reactive components in the feedback loop. Reducing the feedback impedance, especially at higher frequencies, will almost certainly cause stability problems. Likewise capacitance on the inverting input should be avoided. See Application Notes OA-7 and OA-26 for more information on Active Filter applications for Current Feedback Op Amps.

When using the LMH6738 as a low pass filter the value of R_F can be substantially reduced from the value recommended in the R_F vs. Gain charts. The benefit of reducing R_F is increased gain at higher frequencies, which improves attenuation in the stop band. Stability problems are avoided because in the stop band additional device bandwidth is used to cancel the input signal rather than amplify it. The benefit of this change depends on the particulars of the circuit design. With a high pass filter configuration reducing R_F will likely result in device instability and is not recommended.

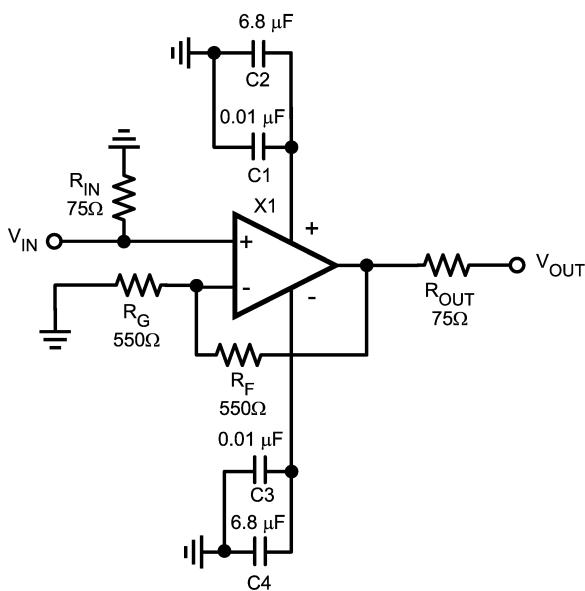
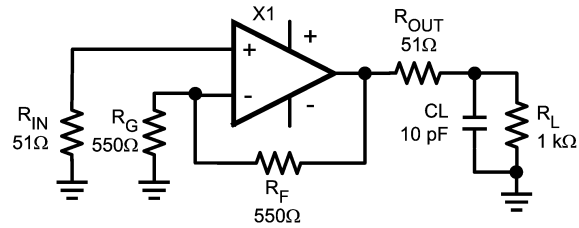

FIGURE 4. Typical Video Application

20097507



20097508

FIGURE 5. Decoupling Capacitive Loads

DRIVING CAPACITIVE LOADS

Capacitive output loading applications will benefit from the use of a series output resistor R_{OUT} . Figure 5 shows the use of a series output resistor, R_{OUT} , to stabilize the amplifier output under capacitive loading. Capacitive loads of 5 to 120 pF are the most critical, causing ringing, frequency response peaking and possible oscillation. The charts "Suggested R_{OUT} vs. Cap Load" give a recommended value for selecting a series output resistor for mitigating capacitive loads. The values suggested in the charts are selected for .5 dB or less of peaking in the frequency response. This gives a good compromise between settling time and bandwidth. For applications where maximum frequency response is needed and some peaking is tolerable, the value of R_{OUT} can be reduced slightly from the recommended values.

An alternative approach is to place R_{out} inside the feedback loop as shown in Figure 6. This will preserve gain accuracy, but will still limit maximum output voltage swing.

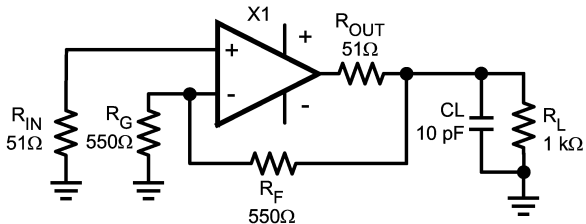

20097509

FIGURE 6. Series Output Resistor Inside Feedback Loop

INVERTING INPUT PARASITIC CAPACITANCE

Parasitic capacitance is any capacitance in a circuit that was not intentionally added. It comes about from electrical interaction between conductors. Parasitic capacitance can be reduced but never entirely eliminated. Most parasitic capacitances that cause problems are related to board layout or lack of termination on transmission lines. Please see the section on Layout Considerations for hints on reducing problems due to parasitic capacitances on board traces. Transmission lines should be terminated in their characteristic impedance at both ends.

High speed amplifiers are sensitive to capacitance between the inverting input and ground or power supplies. This shows up as gain peaking at high frequency. The capacitor raises device gain at high frequencies by making R_G appear smaller. Capacitive output loading will exaggerate this effect. In general, avoid introducing unnecessary parasitic capacitance at both the inverting input and the output.

Application Section (Continued)

One possible remedy for this effect is to slightly increase the value of the feedback (and gain set) resistor. This will tend to offset the high frequency gain peaking while leaving other parameters relatively unchanged. If the device has a capacitive load as well as inverting input capacitance using a series output resistor as described in the section on “Driving Capacitive Loads” will help.

LAYOUT CONSIDERATIONS

Whenever questions about layout arise, use the evaluation board as a guide. The LMH730275 is the evaluation board supplied with samples of the LMH6738.

To reduce parasitic capacitances ground and power planes should be removed near the input and output pins. Components in the feedback loop should be placed as close to the device as possible. For long signal paths controlled impedance lines should be used, along with impedance matching elements at both ends.

Bypass capacitors should be placed as close to the device as possible. Bypass capacitors from each rail to ground are applied in pairs. The larger electrolytic bypass capacitors can be located farther from the device, the smaller ceramic capacitors should be placed as close to the device as possible. The LMH6738 has multiple power and ground pins for enhanced supply bypassing. Every pin should ideally have a separate bypass capacitor. Sharing bypass capacitors may slightly degrade second order harmonic performance, especially if the supply traces are thin and/or long. In *Figure 1* and *Figure 2* C_{SS} is optional, but is recommended for best second harmonic distortion. Another option to using C_{SS} is to use pairs of .01 μF and .1 μF ceramic capacitors for each supply bypass.

VIDEO PERFORMANCE

The LMH6738 has been designed to provide excellent performance with production quality video signals in a wide variety of formats such as HDTV and High Resolution VGA. NTSC and PAL performance is nearly flawless. Best performance will be obtained with back terminated loads. The back termination reduces reflections from the transmission line and effectively masks transmission line and other parasitic capacitances from the amplifier output stage. *Figure 4* shows a typical configuration for driving a 75 Ω Cable. The amplifier is configured for a gain of two to make up for the 6 dB of loss in R_{OUT} .

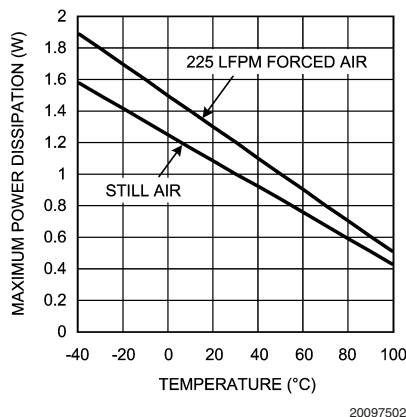

FIGURE 7. Maximum Power Dissipation

POWER DISSIPATION

The LMH6738 is optimized for maximum speed and performance in the small form factor of the standard SSOP-16 package. To achieve its high level of performance, the LMH6738 consumes an appreciable amount of quiescent current which cannot be neglected when considering the total package power dissipation limit. The quiescent current contributes to about 40° C rise in junction temperature when no additional heat sink is used ($V_S = \pm 5\text{V}$, all 3 channels on). Therefore, it is easy to see the need for proper precautions to be taken in order to make sure the junction temperature's absolute maximum rating of 150° C is not violated.

To ensure maximum output drive and highest performance, thermal shutdown is not provided. Therefore, it is of utmost importance to make sure that the T_{JMAX} is never exceeded due to the overall power dissipation (all 3 channels).

With the LMH6738 used in a back-terminated 75 Ω RGB analog video system (with 2 V_{PP} output voltage), the total power dissipation is around 435 mW of which 340 mW is due to the quiescent device dissipation (output black level at 0V). With no additional heat sink used, that puts the junction temperature to about 140° C when operated at 85° C ambient.

To reduce the junction temperature many options are available. Forced air cooling is the easiest option. An external add-on heat-sink can be added to the SSOP-16 package, or alternatively, additional board metal (copper) area can be utilized as heat-sink.

An effective way to reduce the junction temperature for the SSOP-16 package (and other plastic packages) is to use the copper board area to conduct heat. With no enhancement the major heat flow path in this package is from the die through the metal lead frame (inside the package) and onto the surrounding copper through the interconnecting leads. Since high frequency performance requires limited metal near the device pins the best way to use board copper to remove heat is through the bottom of the package. A gap filler with high thermal conductivity can be used to conduct heat from the bottom of the package to copper on the circuit board. Vias to a ground or power plane on the back side of the circuit board will provide additional heat dissipation. A combination of front side copper and vias to the back side can be combined as well.

Follow these steps to determine the Maximum power dissipation for the LMH6738:

1. Calculate the quiescent (no-load) power: $P_{AMP} = I_{CC} \cdot V_S$ where $V_S = V^+ - V^-$
2. Calculate the RMS power dissipated in the output stage: $P_D (rms) = rms((V_S - V_{OUT}) \cdot I_{OUT})$ where V_{OUT} and I_{OUT} are the voltage and current across the external load and V_S is the total supply current
3. Calculate the total RMS power: $P_T = P_{AMP} + P_D$

The maximum power that the LMH6738, package can dissipate at a given temperature can be derived with the following equation (See *Figure 7*):

$P_{MAX} = (150^\circ - T_{AMB}) / \theta_{JA}$, where T_{AMB} = Ambient temperature (°C) and θ_{JA} = Thermal resistance, from junction to ambient, for a given package (°C/W). For the SSOP package θ_{JA} is 120°C/W.

Application Section (Continued)

ESD PROTECTION

The LMH6738 is protected against electrostatic discharge (ESD) on all pins. The LMH6738 will survive 2000V Human Body model and 200V Machine model events.

Under closed loop operation the ESD diodes have no effect on circuit performance. There are occasions, however, when the ESD diodes will be evident. If the LMH6738 is driven by a large signal while the device is powered down the ESD diodes will conduct.

The current that flows through the ESD diodes will either exit the chip through the supply pins or will flow through the device, hence it is possible to power up a chip with a large signal applied to the input pins. Shorting the power pins to each other will prevent the chip from being powered up through the input.

Physical Dimensions inches (millimeters)

unless otherwise noted

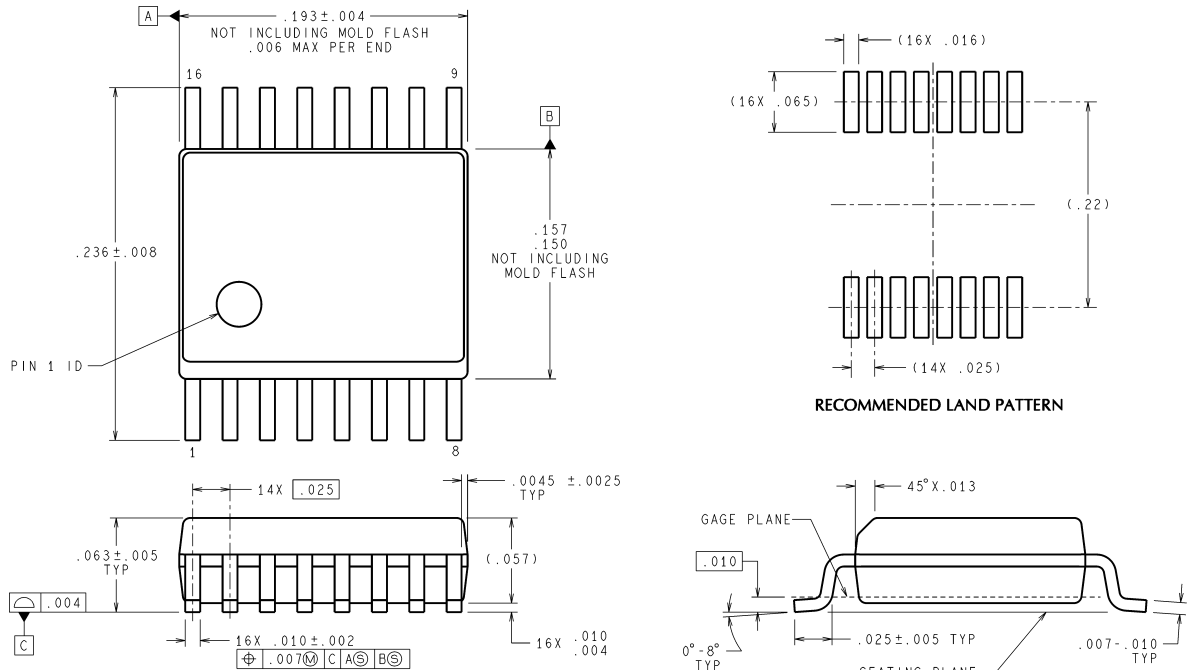

DIMENSIONS ARE IN INCHES
 DIMENSIONS IN () FOR REFERENCE ONLY

MQA16 (Rev B)

16-Pin SSOP NS Package Number MQA16

National does not assume any responsibility for use of any circuitry described, no circuit patent licenses are implied and National reserves the right at any time without notice to change said circuitry and specifications.

For the most current product information visit us at www.national.com.

LIFE SUPPORT POLICY

NATIONAL'S PRODUCTS ARE NOT AUTHORIZED FOR USE AS CRITICAL COMPONENTS IN LIFE SUPPORT DEVICES OR SYSTEMS WITHOUT THE EXPRESS WRITTEN APPROVAL OF THE PRESIDENT AND GENERAL COUNSEL OF NATIONAL SEMICONDUCTOR CORPORATION. As used herein:

1. Life support devices or systems are devices or systems which, (a) are intended for surgical implant into the body, or (b) support or sustain life, and whose failure to perform when properly used in accordance with instructions for use provided in the labeling, can be reasonably expected to result in a significant injury to the user.
2. A critical component is any component of a life support device or system whose failure to perform can be reasonably expected to cause the failure of the life support device or system, or to affect its safety or effectiveness.

BANNED SUBSTANCE COMPLIANCE

National Semiconductor manufactures products and uses packing materials that meet the provisions of the Customer Products Stewardship Specification (CSP-9-111C2) and the Banned Substances and Materials of Interest Specification (CSP-9-111S2) and contain no "Banned Substances" as defined in CSP-9-111S2.

Leadfree products are RoHS compliant.



National Semiconductor
Americas Customer
Support Center
 Email: new.feedback@nsc.com
 Tel: 1-800-272-9959

National Semiconductor
Europe Customer Support Center
 Fax: +49 (0) 180-530 85 86
 Email: europa.support@nsc.com
 Deutsch Tel: +49 (0) 69 9508 6208
 English Tel: +44 (0) 870 24 0 2171
 Français Tel: +33 (0) 1 41 91 8790

National Semiconductor
Asia Pacific Customer
Support Center
 Email: ap.support@nsc.com

National Semiconductor
Japan Customer Support Center
 Fax: 81-3-5639-7507
 Email: jpn.feedback@nsc.com
 Tel: 81-3-5639-7560