

### General Description

The ICS9DB423B is compatible with the Intel DB400Q Differential Buffer Specification. This buffer provides 4 PCI-Express SRC or 4 QPI clocks. The ICS9DB423B is driven by a differential output pair from a CK410B+ or CK509B main clock generator.

### Recommended Application

DB400Q compatible part with PCIe Gen1, Gen 2 and QPI support

### Key Specifications

- Output cycle-cycle jitter < 50ps
- Output to Output skew <50ps
- Phase jitter: PCIe Gen1 < 86ps peak to peak
- Phase jitter: PCIe Gen2 < 3.0/3.1ps rms
- Phase jitter: QPI < 0.5ps rms

### Features/Benefits

- Spread spectrum modulation tolerant, 0 to -0.5% down spread and +/- 0.25% center spread
- Supports undriven differential outputs in Power Down and DIF\_STOP# for modes for power management.

### Output Features

- 4 - 0.7V current-mode differential output pairs
- Supports zero delay buffer mode and fanout mode
- Bandwidth programming available
- 50-133 MHz operation in PLL mode
- 33-400 MHz operation in Bypass mode

### Functional Block Diagram

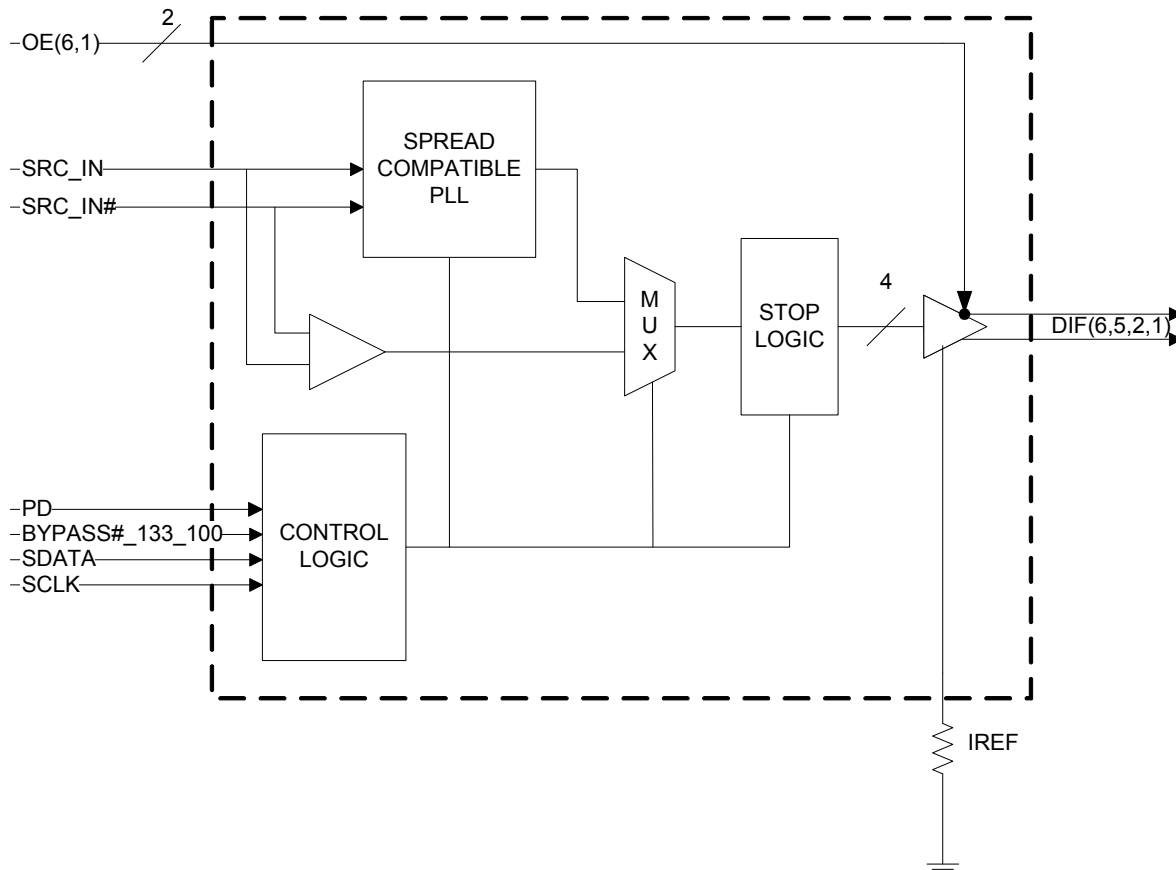

## Pin Configuration

VDDR	1		28	VDDA
SRC_IN	2		27	GNDA
SRC_IN#	3		26	IREF
GND	4		25	OE_INV
VDD	5		24	VDD
DIF_1	6		23	DIF_6
DIF_1#	7		22	DIF_6#
OE_1	8		21	OE_6
DIF_2	9		20	DIF_5
DIF_2#	10		19	DIF_5#
VDD	11		18	VDD
BYPASS#_133_100	12		17	HIGH_BW#
SCLK	13		16	DIF_STOP#
SDATA	14		15	PD#

**9DB423  
(same as 9DB104)**

**OE\_INV = 0**

VDDR	1		28	VDDA
SRC_IN	2		27	GNDA
SRC_IN#	3		26	IREF
GND	4		25	OE_INV
VDD	5		24	VDD
DIF_1	6		23	DIF_6
DIF_1#	7		22	DIF_6#
OE1#	8		21	OE6#
DIF_2	9		20	DIF_5
DIF_2#	10		19	DIF_5#
VDD	11		18	VDD
BYPASS#_133_100	12		17	HIGH_BW#
SCLK	13		16	DIF_STOP
SDATA	14		15	PD#

**9DB423  
(same as 9DB403)**

**OE\_INV = 1**

Note: Pin 15 is always active low. This is different than 9DB403.

## 28-pin SSOP and TSSOP

### Polarity Inversion Pin List Table

Pins	OE_INV	
	0	1
8	OE_1	OE1#
15	PD#	PD#
16	DIF_STOP#	DIF_STOP
Various	OE_x	OE_x#

### Power Groups

Pin Number		Description
VDD	GND	
1	4	SRC_IN/SRC_IN#
5, 11, 18, 24	4	DIF(1,2,5,6)
N/A	27	IREF
28	27	Analog VDD & GND for PLL core

### Frequency Selection

BYPASS#_133_100	Voltage	MODE
Low	<0.8V	Bypass
Mid	1.2<Vin<1.8V	QPI 133MHz
High	Vin > 2.0V	PCIe 100MHz

### Bypass Readback Table

BYPASS#_133_100	Byte0, bit 3	Byte 0 bit 1
Low	0	0
Mid	1	0
High	0	1

## Pin Descriptions for OE\_INV=0

PIN #	PIN NAME	PIN TYPE	DESCRIPTION
1	VDDR	PWR	3.3V power for differential input clock (receiver). This VDD should be treated as an analog power rail and filtered appropriately.
2	SRC_IN	IN	0.7 V Differential SRC TRUE input
3	SRC_IN#	IN	0.7 V Differential SRC COMPLEMENTARY input
4	GND	PWR	Ground pin.
5	VDD	PWR	Power supply, nominal 3.3V
6	DIF_1	OUT	0.7V differential true clock output
7	DIF_1#	OUT	0.7V differential Complementary clock output
8	OE_1	IN	Active high input for enabling output 1. 0 =disable outputs, 1= enable outputs
9	DIF_2	OUT	0.7V differential true clock output
10	DIF_2#	OUT	0.7V differential Complementary clock output
11	VDD	PWR	Power supply, nominal 3.3V
12	BYPASS#_133_100	IN	Input to select Bypass(fan-out), QPI PLL (133MHz) or PCIe PLL (100MHz) mode 0 = Bypass mode, M= QPI, 1= PCIe PLL mode
13	SCLK	IN	Clock pin of SMBus circuitry, 5V tolerant.
14	SDATA	I/O	Data pin for SMBus circuitry, 5V tolerant.
15	PD#	IN	Asynchronous active low input pin used to power down the device. The internal clocks are disabled and the VCO and the crystal osc. (if any) are stopped.
16	DIF_STOP#	IN	Active low input to stop differential output clocks.
17	HIGH_BW#	IN	3.3V input for selecting PLL Band Width 0 = High, 1= Low
18	VDD	PWR	Power supply, nominal 3.3V
19	DIF_5#	OUT	0.7V differential Complementary clock output
20	DIF_5	OUT	0.7V differential true clock output
21	OE_6	IN	Active high input for enabling output 6. 0 =disable outputs, 1= enable outputs
22	DIF_6#	OUT	0.7V differential Complementary clock output
23	DIF_6	OUT	0.7V differential true clock output
24	VDD	PWR	Power supply, nominal 3.3V
25	OE_INV	IN	This latched input selects the polarity of the OE pins. 0 = OE pins active high, 1 = OE pins active low (OE#)
26	IREF	OUT	This pin establishes the reference for the differential current-mode output pairs. It requires a fixed precision resistor to ground. 475ohm is the standard value for 100ohm differential impedance. Other impedances require different values. See data sheet.
27	GNDA	PWR	Ground pin for the PLL core.
28	VDDA	PWR	3.3V power for the PLL core.

## Pin Descriptions for OE\_INV=1

PIN #	PIN NAME	PIN TYPE	DESCRIPTION
1	VDDR	PWR	3.3V power for differential input clock (receiver). This VDD should be treated as an analog power rail and filtered appropriately.
2	SRC_IN	IN	0.7 V Differential SRC TRUE input
3	SRC_IN#	IN	0.7 V Differential SRC COMPLEMENTARY input
4	GND	PWR	Ground pin.
5	VDD	PWR	Power supply, nominal 3.3V
6	DIF_1	OUT	0.7V differential true clock output
7	DIF_1#	OUT	0.7V differential Complementary clock output
8	OE1#	IN	Active low input for enabling DIF pair 1. 1 =disable outputs, 0 = enable outputs
9	DIF_2	OUT	0.7V differential true clock output
10	DIF_2#	OUT	0.7V differential Complementary clock output
11	VDD	PWR	Power supply, nominal 3.3V
12	BYPASS#_133_100	IN	Input to select Bypass(fan-out), QPI PLL (133MHz) or PCIe PLL (100MHz) mode 0 = Bypass mode, M= QPI, 1= PCIe PLL mode
13	SCLK	IN	Clock pin of SMBus circuitry, 5V tolerant.
14	SDATA	I/O	Data pin for SMBus circuitry, 5V tolerant.
15	PD#	IN	Asynchronous active low input pin used to power down the device. The internal clocks are disabled and the VCO and the crystal osc. (if any) are stopped.
16	DIF_STOP	IN	Active High input to stop differential output clocks.
17	HIGH_BW#	IN	3.3V input for selecting PLL Band Width 0 = High, 1= Low
18	VDD	PWR	Power supply, nominal 3.3V
19	DIF_5#	OUT	0.7V differential Complementary clock output
20	DIF_5	OUT	0.7V differential true clock output
21	OE6#	IN	Active low input for enabling DIF pair 6. 1 =disable outputs, 0 = enable outputs
22	DIF_6#	OUT	0.7V differential Complementary clock output
23	DIF_6	OUT	0.7V differential true clock output
24	VDD	PWR	Power supply, nominal 3.3V
25	OE_INV	IN	This latched input selects the polarity of the OE pins. 0 = OE pins active high, 1 = OE pins active low (OE#)
26	IREF	OUT	This pin establishes the reference for the differential current-mode output pairs. It requires a fixed precision resistor to ground. 475ohm is the standard value for 100ohm differential impedance. Other impedances require different values. See data sheet.
27	GNDA	PWR	Ground pin for the PLL core.
28	VDDA	PWR	3.3V power for the PLL core.

## Absolute Maximum Ratings

Stresses above the ratings listed below can cause permanent damage to the ICS9DB423B. These ratings, which are standard values for IDT commercially rated parts, are stress ratings only. Functional operation of the device at these or any other conditions above those indicated in the operational sections of the specifications is not implied. Exposure to absolute maximum rating conditions for extended periods can affect product reliability. Electrical parameters are guaranteed only over the recommended operating temperature range.

Symbol	Parameter	Min	Max	Units
VDDA/R	3.3V Core Supply Voltage		4.6	V
VDD	3.3V Logic Supply Voltage		4.6	V
V <sub>IL</sub>	Input Low Voltage	GND-0.5		V
V <sub>IH</sub>	Input High Voltage		V <sub>DD</sub> +0.5V	V
T <sub>s</sub>	Storage Temperature	-65	150	°C
T <sub>ambient</sub>	Ambient Operating Temp	0	70	°C
T <sub>case</sub>	Case Temperature		115	°C
ESD prot	Input ESD protection human body model	2000		V

## Electrical Characteristics—Clock Input Parameters

T<sub>A</sub> = 0 - 70°C; Supply Voltage V<sub>DD</sub> = 3.3 V +/-5%

PARAMETER	SYMBOL	CONDITIONS	MIN	TYP	MAX	UNITS	NOTES
Input High Voltage - DIF_IN	V <sub>IHDIF</sub>	Differential inputs (single-ended measurement)	600	800	1150	mV	1
Input Low Voltage - DIF_IN	V <sub>ILDIF</sub>	Differential inputs (single-ended measurement)	V <sub>SS</sub> - 300	0	300	mV	1
Input Common Mode Voltage - DIF_IN	V <sub>COM</sub>	Common Mode Input Voltage	300		1000	mV	1
Input Amplitude - DIF_IN	V <sub>SWING</sub>	Peak to Peak value	300		1450	mV	1
Input Slew Rate - DIF_IN	dv/dt	Measured differentially	0.4		8	V/ns	1,2
Input Leakage Current	I <sub>IN</sub>	V <sub>IN</sub> = V <sub>DD</sub> , V <sub>IN</sub> = GND	-5		5	uA	1
Input Duty Cycle	d <sub>in</sub>	Measurement from differential waveform	45		55	%	1
Input Jitter - Cycle to Cycle	J <sub>DIFin</sub>	Differential Measurement	0		125	ps	1

<sup>1</sup> Guaranteed by design and characterization, not 100% tested in production.

<sup>2</sup> Slew rate measured through V<sub>swing</sub> min centered around differential zero

## Electrical Characteristics–Input/Supply/Common Output Parameters

T<sub>A</sub> = 0 - 70°C; Supply Voltage V<sub>DD</sub> = 3.3 V +/-5%

PARAMETER	SYMBOL	CONDITIONS	MIN	TYP	MAX	UNITS
Input High Voltage	V <sub>IH</sub>	3.3 V +/-5%	2		V <sub>DD</sub> + 0.3	V
Input Low Voltage	V <sub>IL</sub>	3.3 V +/-5%	GND - 0.3		0.8	V
Input High Current	I <sub>IH</sub>	V <sub>IN</sub> = V <sub>DD</sub>	-5		5	uA
Input Low Current	I <sub>IL1</sub>	V <sub>IN</sub> = 0 V; Inputs with no pull-up resistors	-5			uA
	I <sub>IL2</sub>	V <sub>IN</sub> = 0 V; Inputs with pull-up resistors	-200			uA
Operating Supply Current	I <sub>DD3.3OP</sub>	Full Active, C <sub>L</sub> = Full load;			200	mA
Powerdown Current	I <sub>DD3.3PD</sub>	all diff pairs driven			60	mA
		all differential pairs tri-stated			6	mA
Input Frequency	F <sub>iPLL</sub>	PCIe Mode (Bypass/133/100= 1)	50	100.00	110	MHz
	F <sub>iPLL</sub>	QPI Mode (Bypass/133/100= M)	67	133.33	140	MHz
	F <sub>iBYPASS</sub>	Bypass Mode (Bypass/133/100= 0)	33		400	MHz
Pin Inductance	L <sub>pin</sub>				7	nH
Capacitance	C <sub>IN</sub>	Logic Inputs, except SRC_IN	1.5		5	pF
	C <sub>INSRC_IN</sub>	SRC_IN differential clock inputs	1.5		2.7	pF
	C <sub>OUT</sub>	Output pin capacitance			6	pF
PLL Bandwidth	BW	-3dB point in High BW Mode	2	3	4	MHz
		-3dB point in Low BW Mode	0.7	1	1.4	MHz
PLL Jitter Peaking	t <sub>JPEAK</sub>	Peak Pass band Gain		1.5	2	dB
Clk Stabilization	T <sub>STAB</sub>	From V <sub>DD</sub> Power-Up and after input clock stabilization or de-assertion of PD# to 1st clock			1	ms
Input SS Modulation Frequency	f <sub>MODIN</sub>	Allowable Frequency (Triangular Modulation)	30		33	kHz
OE# Latency	t <sub>LATOE#</sub>	DIF start after OE# assertion DIF stop after OE# deassertion	1		3	cycles
Tdrive_DIF_Stop#	t <sub>DRVSTP</sub>	DIF output enable after DIF_Stop# de-assertion			10	ns
Tdrive_PD#	t <sub>DRVPD</sub>	DIF output enable after PD# de-assertion			300	us
Tfall	t <sub>F</sub>	Fall time of PD# and DIF_Stop#			5	ns
Trise	t <sub>R</sub>	Rise time of PD# and DIF_Stop#			5	ns
SMBus Voltage	V <sub>MAX</sub>	Maximum input voltage			5.5	V
Low-level Output Voltage	V <sub>OL</sub>	@ I <sub>PULLUP</sub>			0.4	V
Current sinking at V <sub>OL</sub>	I <sub>PULLUP</sub>		4			mA
SCLK/SDATA Clock/Data Rise Time	t <sub>RSMB</sub>	(Max V <sub>IL</sub> - 0.15) to (Min V <sub>IH</sub> + 0.15)			1000	ns
SCLK/SDATA Clock/Data Fall Time	t <sub>FSMB</sub>	(Min V <sub>IH</sub> + 0.15) to (Max V <sub>IL</sub> - 0.15)			300	ns
SMBus Operating Frequency	f <sub>MAXSMB</sub>	Maximum SMBus operating frequency			100	kHz

<sup>1</sup>Guaranteed by design and characterization, not 100% tested in production.

<sup>2</sup>See timing diagrams for timing requirements.

<sup>3</sup>Time from deassertion until outputs are >200 mV

<sup>4</sup>SRC\_IN input

<sup>5</sup>The differential input clock must be running for the SMBus to be active

## Electrical Characteristics—DIF 0.7V Current Mode Differential Pair

$T_A = 0 - 70^\circ\text{C}$ ;  $V_{DD} = 3.3\text{ V} \pm 5\%$ ;  $C_L = 2\text{pF}$ ,  $R_S = 33\Omega$ ,  $R_P = 49.9\Omega$ ,  $R_{REF} = 475\Omega$

PARAMETER	SYMBOL	CONDITIONS	MIN	TYP	MAX	UNITS	NOTES
Current Source Output Impedance	$Z_o^1$		3000			$\Omega$	1
Voltage High	VHigh	Statistical measurement on single ended signal using oscilloscope math function.	660		850	mV	1,2
Voltage Low	VLow		-150		150		1,2
Max Voltage	Vovs	Measurement on single ended signal using absolute value.			1150	mV	1
Min Voltage	Vuds		-300				1
Crossing Voltage (abs)	Vcross(abs)		250		550	mV	1
Crossing Voltage (var)	d-Vcross	Variation of crossing over all edges			140	mV	1
Rise Time	$t_r$	$V_{OL} = 0.175\text{V}$ , $V_{OH} = 0.525\text{V}$	175		700	ps	1
Fall Time	$t_f$	$V_{OH} = 0.525\text{V}$ , $V_{OL} = 0.175\text{V}$	175		700	ps	1
Rise Time Variation	d- $t_r$				125	ps	1
Fall Time Variation	d- $t_f$				125	ps	1
Duty Cycle	$d_{t3}$	Measurement from differential waveform	45		55	%	1
Skew, Input to Output	$t_{pdBYP}$	Bypass Mode, $V_T = 50\%$	2500		4500	ps	1
	$t_{pdPLL}$	PLL Mode $V_T = 50\%$	-250		250	ps	1
Skew, Output to Output	$t_{sk3}$	$V_T = 50\%$			50	ps	1
Jitter, Cycle to cycle	$t_{j\text{cyc-cyc}}$	PLL mode			50	ps	1,3
		Additive Jitter in Bypass Mode			50	ps	1,3
Jitter, Phase	$t_{j\text{phaseBYP}}$	PCIe Gen1 phase jitter (Additive in Bypass Mode)		7	10	ps (pk2pk)	1,4,5
		PCIe Gen 2 Low Band phase jitter (Additive in Bypass Mode)		0	0.1	ps (rms)	1,4,5
		PCIe Gen 2 High Band phase jitter (Additive in Bypass Mode)		0.7	0.9	ps (rms)	1,4,5
		QPI phase jitter (Additive in Bypass Mode)			0.16	ps (rms)	1,5,6
	$t_{j\text{phasePLL}}$	PCIe Gen 1 phase jitter		37	86	ps (pk2pk)	1,4,5
		PCIe Gen 2 Low Band phase jitter		1.5	3	ps (rms)	1,4,5
		PCIe Gen 2 High Band phase jitter		2.7/ 2.2	3.1	ps (rms)	1,4,5,7
		QPI phase jitter		0.28	0.5	ps (rms)	1,5,6

<sup>1</sup>Guaranteed by design and characterization, not 100% tested in production.

<sup>2</sup> $I_{REF} = V_{DD}/(3 \times R_R)$ . For  $R_R = 475\Omega$  (1%),  $I_{REF} = 2.32\text{mA}$ .  $I_{OH} = 6 \times I_{REF}$  and  $V_{OH} = 0.7\text{V}$  @  $Z_O = 50\Omega$ .

<sup>3</sup> Measured from differential waveform

<sup>4</sup> See <http://www.pcisig.com> for complete specs

<sup>5</sup> Device driven by 932S421C or equivalent.

<sup>6</sup> 6.4Gb 12UI

<sup>7</sup> First number is High Bandwidth Mode, second number is Low Bandwidth Mode

## Clock Periods–Differential Outputs with Spread Spectrum Enabled

Measurement Window		1 Clock	1us	0.1s	0.1s	0.1s	1us	1 Clock		
Symbol		Lg-	-SSC	-ppm error	0ppm	+ ppm error	+SSC	Lg+		
Definition		Absolute Period	Short-term Average	Long-Term Average	Period	Long-Term Average	Short-term Average	Period		
		Minimum Absolute Period	Minimum Absolute Period	Minimum Absolute Period	Nominal	Maximum	Maximum	Maximum	Units	Notes
Signal Name	DIF 100	9.949	9.999	10.024	10.025	10.026	10.051	10.101	ns	1,2,3
	DIF 133	7.449	7.499	7.518	7.519	7.520	7.538	7.588	ns	1,2,4
	DIF 166	5.949	5.999	6.014	6.015	6.016	6.031	6.081	ns	1,2,5
	DIF 200	4.950	5.000	5.012	5.013	5.013	5.026	5.076	ns	1,2,5
	DIF 266	3.700	3.750	3.759	3.759	3.760	3.769	3.819	ns	1,2,5
	DIF 333	2.950	3.000	3.007	3.008	3.008	3.015	3.065	ns	1,2,5
	DIF 400	2.450	2.500	2.506	2.506	2.507	2.513	2.563	ns	1,2,5

## Clock Periods–Differential Outputs with Spread Spectrum Disabled

Measurement Window		1 Clock	1us	0.1s	0.1s	0.1s	1us	1 Clock		
Symbol		Lg-	-SSC	-ppm error	0ppm	+ ppm error	+SSC	Lg+		
Definition		Absolute Period	Short-term Average	Long-Term Average	Period	Long-Term Average	Short-term Average	Period		
		Minimum Absolute Period	Minimum Absolute Period	Minimum Absolute Period	Nominal	Maximum	Maximum	Maximum	Units	Notes
Signal Name	DIF 100	9.949		9.999	10.000	10.001		10.051	ns	1,2,3
	DIF 133	7.449		7.499	7.500	7.501		7.551	ns	1,2,4
	DIF 166	5.949		5.999	6.000	6.001		6.051	ns	1,2,5
	DIF 200	4.950		5.000	5.000	5.001		5.051	ns	1,2,5
	DIF 266	3.700		3.750	3.750	3.750		3.800	ns	1,2,5
	DIF 333	2.950		3.000	3.000	3.000		3.050	ns	1,2,5
	DIF 400	2.450		2.500	2.500	2.500		2.550	ns	1,2,5

<sup>1</sup>Guaranteed by design and characterization, not 100% tested in production.

<sup>2</sup>All Long Term Accuracy specifications are guaranteed with the assumption that the input clock complies with CK410B+ accuracy requirements. The 9DB423/823 itself does not contribute to ppm error.

<sup>3</sup> Driven by SRC output of main clock, PCIe PLL Mode or Bypass mode

<sup>4</sup> Driven by CPU output of main clock, QPI PLL Mode or Bypass mode

<sup>5</sup> Driven by CPU output of CK410B+/CK420BQ/CK505 main clock, **Bypass mode only**



DIF Reference Clock			
Common Recommendations for Differential Routing	Dimension or Value	Unit	Figure
L1 length, route as non-coupled 50ohm trace	0.5 max	inch	1
L2 length, route as non-coupled 50ohm trace	0.2 max	inch	1
L3 length, route as non-coupled 50ohm trace	0.2 max	inch	1
Rs	33	ohm	1
Rt	49.9	ohm	1

Down Device Differential Routing			
L4 length, route as coupled microstrip 100ohm differential trace	2 min to 16 max	inch	1
L4 length, route as coupled stripline 100ohm differential trace	1.8 min to 14.4 max	inch	1

Differential Routing to PCI Express Connector			
L4 length, route as coupled microstrip 100ohm differential trace	0.25 to 14 max	inch	2
L4 length, route as coupled stripline 100ohm differential trace	0.225 min to 12.6 max	inch	2

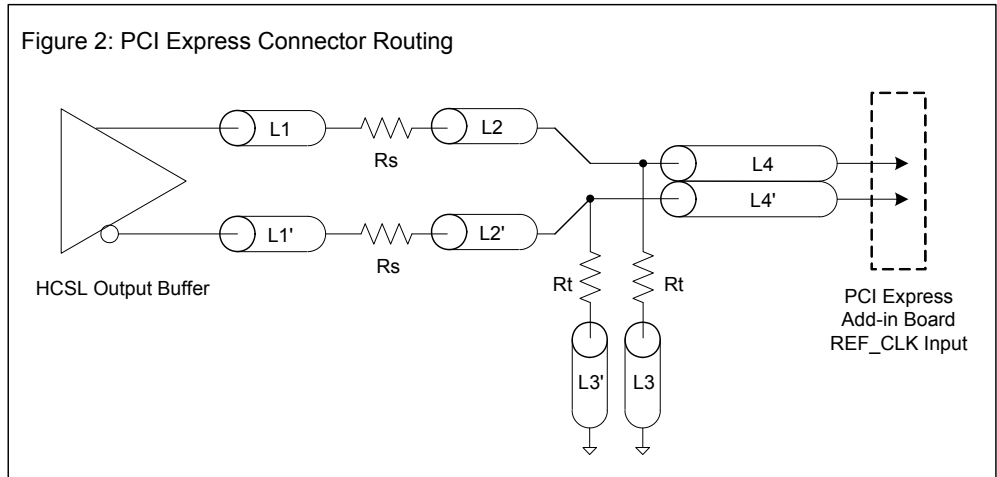
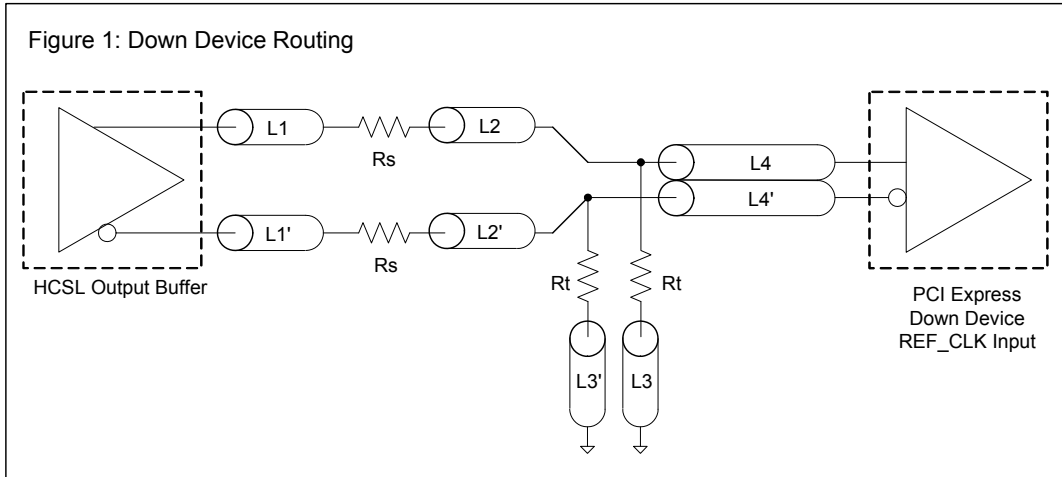

**Alternative Termination for LVDS and other Common Differential Signals (figure 3)**

V <sub>diff</sub>	V <sub>p-p</sub>	V <sub>cm</sub>	R1	R2	R3	R4	Note
0.45v	0.22v	1.08	33	150	100	100	
0.58	0.28	0.6	33	78.7	137	100	
0.80	0.40	0.6	33	78.7	none	100	ICS874003i-02 input compatible
0.60	0.3	1.2	33	174	140	100	Standard LVDS

R1a = R1b = R1

R2a = R2b = R2

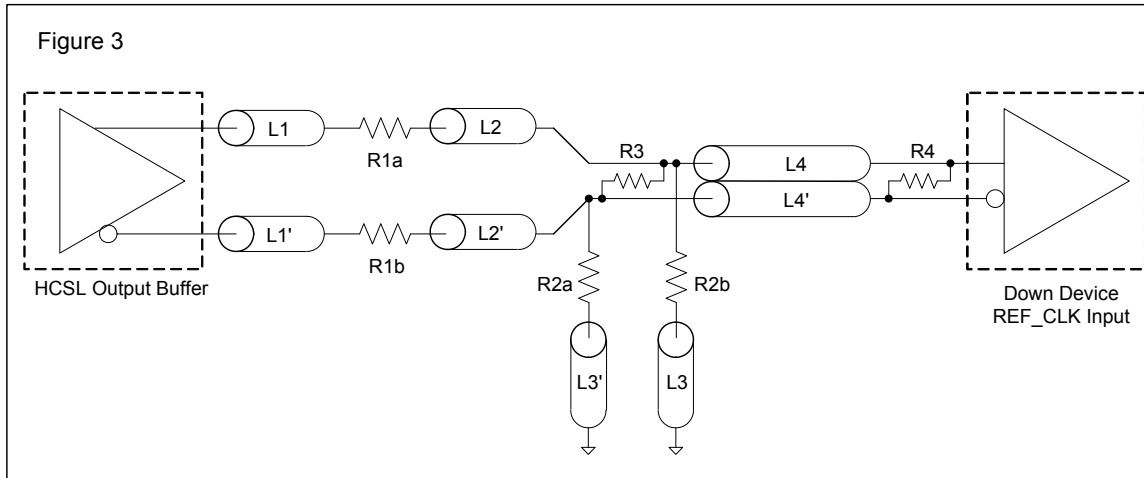

**Cable Connected AC Coupled Application (figure 4)**

Component	Value	Note
R5a, R5b	8.2K 5%	
R6a, R6b	1K 5%	
Cc	0.1 μF	
V <sub>cm</sub>	0.350 volts	

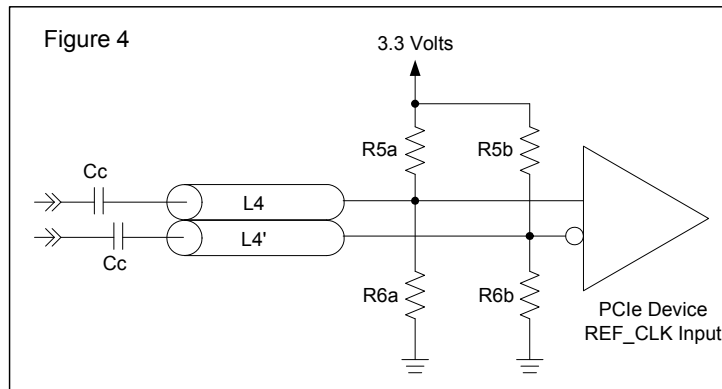

## General SMBus Serial Interface Information

### How to Write

- Controller (host) sends a start bit
- Controller (host) sends the write address  $DC_{(h)}$
- IDT clock will **acknowledge**
- Controller (host) sends the beginning byte location = N
- IDT clock will **acknowledge**
- Controller (host) sends the byte count = X
- IDT clock will **acknowledge**
- Controller (host) starts sending Byte N through Byte N+X-1
- IDT clock will **acknowledge** each byte **one at a time**
- Controller (host) sends a Stop bit

Index Block Write Operation			
Controller (Host)			IDT (Slave/Receiver)
T	starT bit		
Slave Address $DC_{(h)}$			
WR	WRite		
Beginning Byte = N			ACK
			ACK
Data Byte Count = X			ACK
Beginning Byte N		X Byte	ACK
O			O
O			O
O			O
Byte N + X - 1			ACK
P	stoP bit		

Read Address	Write Address
$DD_{(h)}$	$DC_{(h)}$

### How to Read

- Controller (host) will send a start bit
- Controller (host) sends the write address  $DC_{(h)}$
- IDT clock will **acknowledge**
- Controller (host) sends the beginning byte location = N
- IDT clock will **acknowledge**
- Controller (host) will send a separate start bit
- Controller (host) sends the read address  $DD_{(h)}$
- IDT clock will **acknowledge**
- IDT clock will send the data byte count = X
- IDT clock sends Byte N+X-1
- IDT clock sends **Byte 0 through Byte X (if  $X_{(H)}$  was written to Byte 8)**
- Controller (host) will need to acknowledge each byte
- Controller (host) will send a not acknowledge bit
- Controller (host) will send a stop bit

Index Block Read Operation			
Controller (Host)			IDT (Slave/Receiver)
T	starT bit		
Slave Address $DC_{(h)}$			
WR	WRite		
Beginning Byte = N			ACK
			ACK
RT	Repeat starT		
Slave Address $DD_{(h)}$			
RD	ReaD		
			ACK
ACK		X Byte	Data Byte Count=X
ACK			Beginning Byte N
O			O
O			O
O			O
			Byte N + X - 1
N	Not acknowledge		
P	stoP bit		

SMBus Table: Frequency Select Register, READ/WRITE ADDRESS (DC/DD)

Byte 0	Pin #	Name	Control Function	Type	0	1	Default
Bit 7	-	PD_Mode	PD# drive mode	RW	driven	Hi-Z	0
Bit 6	-	STOP_Mode	DIF_Stop# drive mode	RW	driven	Hi-Z	0
Bit 5	-	PD_Polarity	Select PD polarity	RW	Low	High	0
Bit 4	-	Reserved					X
Bit 3	-	BYPASS#1	BYPASS#/PLL1	RW	See Bypass Readback Table		Input
Bit 2	-	PLL_BW#	Select PLL BW	RW	High BW	Low BW	1
Bit 1	-	BYPASS#0	BYPASS#/PLL0	RW	See Bypass Readback Table		Input
Bit 0	-	SRC_DIV#	SRC Divide by 2 Select	RW	x/2	x/1	1

SMBus Table: Output Control Register

Byte 1	Pin #	Name	Control Function	Type	0	1	Default
Bit 7		Reserved					1
Bit 6	22,23	DIF_6	Output Enable	RW	Disable	Enable	1
Bit 5	19,20	DIF_5	Output Enable	RW	Disable	Enable	1
Bit 4		Reserved					1
Bit 3		Reserved					1
Bit 2	9,10	DIF_2	Output Enable	RW	Disable	Enable	1
Bit 1	6,7	DIF_1	Output Enable	RW	Disable	Enable	1
Bit 0		Reserved					1

**NOTE:** The SMBus Output Enable Bit must be '1' AND the respective OE pin must be active for the output to run!

SMBus Table: OE Pin Control Register

Byte 2	Pin #	Name	Control Function	Type	0	1	Default
Bit 7		Reserved					0
Bit 6	22,23	DIF_6	DIF_6 Stoppable with DIFSTOP	RW	Free-run	Stoppable	0
Bit 5	19,20	DIF_5	DIF_5 Stoppable with DIFSTOP	RW	Free-run	Stoppable	0
Bit 4		Reserved					0
Bit 3		Reserved					0
Bit 2	9,10	DIF_2	DIF_2 Stoppable with DIFSTOP	RW	Free-run	Stoppable	0
Bit 1	6,7	DIF_1	DIF_1 Stoppable with DIFSTOP	RW	Free-run	Stoppable	0
Bit 0		Reserved					0

SMBus Table: Reserved Register

Byte 3	Pin #	Name	Control Function	Type	0	1	Default
Bit 7		Reserved					X
Bit 6		Reserved					X
Bit 5		Reserved					X
Bit 4		Reserved					X
Bit 3		Reserved					X
Bit 2		Reserved					X
Bit 1		Reserved					X
Bit 0		Reserved					X

SMBus Table: Vendor &amp; Revision ID Register

Byte 4	Pin #	Name	Control Function	Type	0	1	Default
Bit 7	-	RID3	REVISION ID	R	-	-	0
Bit 6	-	RID2		R	-	-	0
Bit 5	-	RID1		R	-	-	0
Bit 4	-	RID0		R	-	-	1
Bit 3	-	VID3	VENDOR ID	R	-	-	0
Bit 2	-	VID2		R	-	-	0
Bit 1	-	VID1		R	-	-	0
Bit 0	-	VID0		R	-	-	1

SMBus Table: DEVICE ID

Byte 5	Pin #	Name	Control Function	Type	0	1	Default
Bit 7	-	Device ID 7 (MSB)		R	Device ID is 42 Hex for 9DB423		0
Bit 6	-	Device ID 6		R			1
Bit 5	-	Device ID 5		R			0
Bit 4	-	Device ID 4		R			0
Bit 3	-	Device ID 3		R			0
Bit 2	-	Device ID 2		R			0
Bit 1	-	Device ID 1		R			1
Bit 0	-	Device ID 0		R			0

SMBus Table: Byte Count Register

Byte 6	Pin #	Name	Control Function	Type	0	1	Default
Bit 7	-	BC7	Writing to this register configures how many bytes will be read back.	RW	-	-	0
Bit 6	-	BC6		RW	-	-	0
Bit 5	-	BC5		RW	-	-	0
Bit 4	-	BC4		RW	-	-	0
Bit 3	-	BC3		RW	-	-	0
Bit 2	-	BC2		RW	-	-	1
Bit 1	-	BC1		RW	-	-	1
Bit 0	-	BC0		RW	-	-	1

Note: Polarities in timing diagrams are shown OE\_INV = 0. They are similar to OE\_INV = 1.

### PD#, Power Down

The PD# pin cleanly shuts off all clocks and places the device into a power saving mode. PD# must be asserted before shutting off the input clock or power to insure an orderly shutdown. PD is asynchronous active-low input for both powering down the device and powering up the device. When PD# is asserted, all clocks will be driven high, or tri-stated (depending on the PD# drive mode and Output control bits) before the PLL is shut down.

### PD# Assertion

When PD# is sampled low by two consecutive rising edges of DIF#, all DIF outputs must be held High, or tri-stated (depending on the PD# drive mode and Output control bits) on the next High-Low transition of the DIF# outputs. When the PD# drive mode bit is set to '0', all clock outputs will be held with DIF driven High with 2 x IREF and DIF# tri-stated. If the PD# drive mode bit is set to '1', both DIF and DIF# are tri-stated.

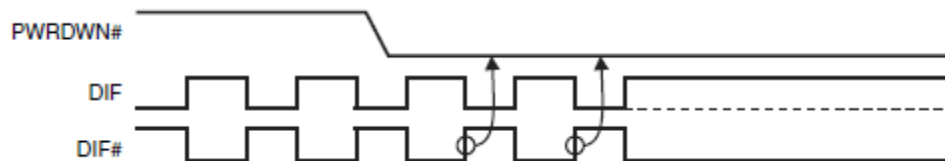

### PD# De-assertion

Power-up latency is less than 1 ms. This is the time from de-assertion of the PD# pin, or VDD reaching 3.3V, or the time from valid SRC\_IN clocks until the time that stable clocks are output from the device (PLL Locked). If the PD# drive mode bit is set to '1', all the DIF outputs must driven to a voltage of >200 mV within 300 us of PD# de-assertion.

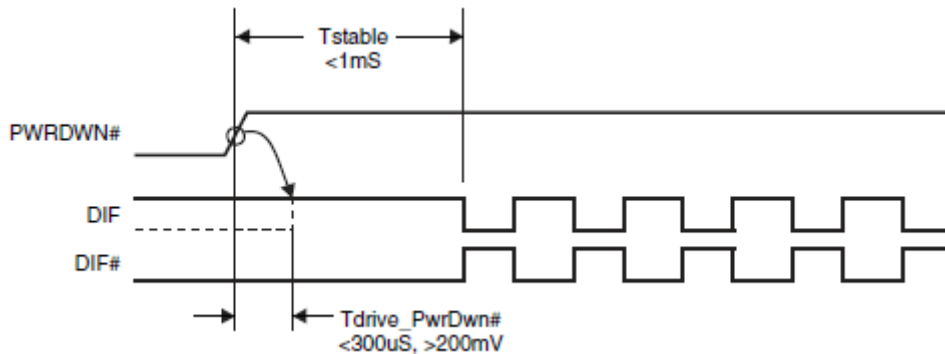

## DIF\_STOP#

The DIF\_STOP# signal is an active-low asynchronous input that cleanly stops and starts the DIF outputs. A valid clock must be present on SRC\_IN for this input to work properly. The DIF\_STOP# signal is de-bounced and must remain stable for two consecutive rising edges of DIF# to be recognized as a valid assertion or de-assertion.

### DIF\_STOP# – Assertion

Asserting DIF\_STOP# causes all DIF outputs to stop after their next transition (if the control register settings allow the output to stop). When the DIF\_STOP# drive bit is '0', the final state of all stopped DIF outputs is DIF = High and DIF# = Low. There is no change in output drive current. DIF is driven with 6xIREF. DIF# is not driven, but pulled low by the termination. When the DIF\_STOP# drive bit is '1', the final state of all DIF output pins is Low. Both DIF and DIF# are not driven.

### DIF\_STOP# – De-assertion (transition from '0' to '1')

All stopped differential outputs resume normal operation in a glitch-free manner. The de-assertion latency to active outputs is 2-6 DIF clock periods, with all DIF outputs resuming simultaneously. If the DIF\_STOP# drive control bit is '1' (tri-state), all stopped DIF outputs must be driven High (>200 mV) within 10 ns of de-assertion

### DIF\_STOP\_1 (Stop\_Mode = Driven, PD\_Mode = Driven)

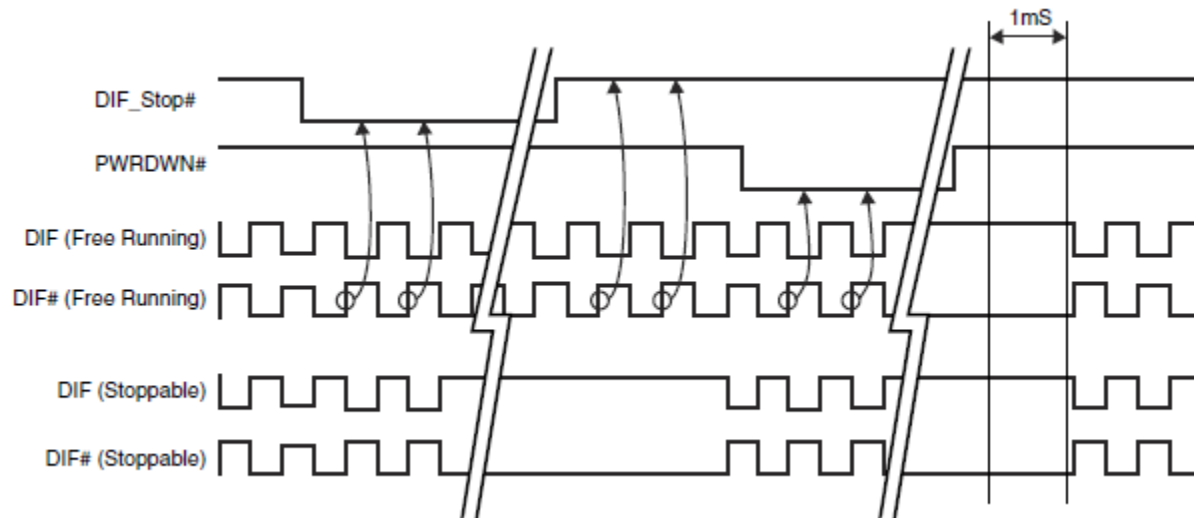

### DIF\_STOP\_2 (Stop\_Mode = Tristate, PD\_Mode = Driven)

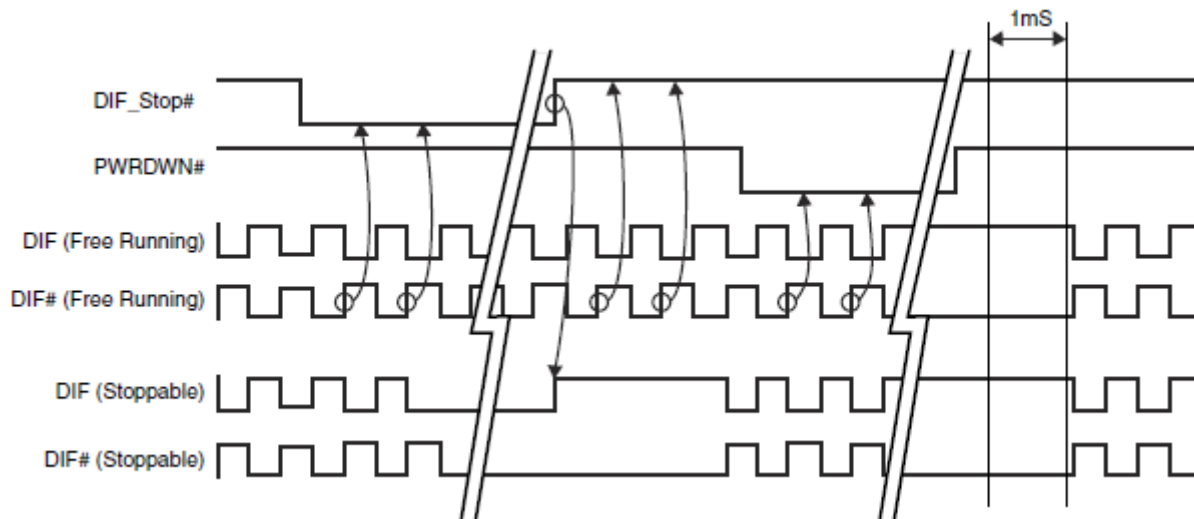

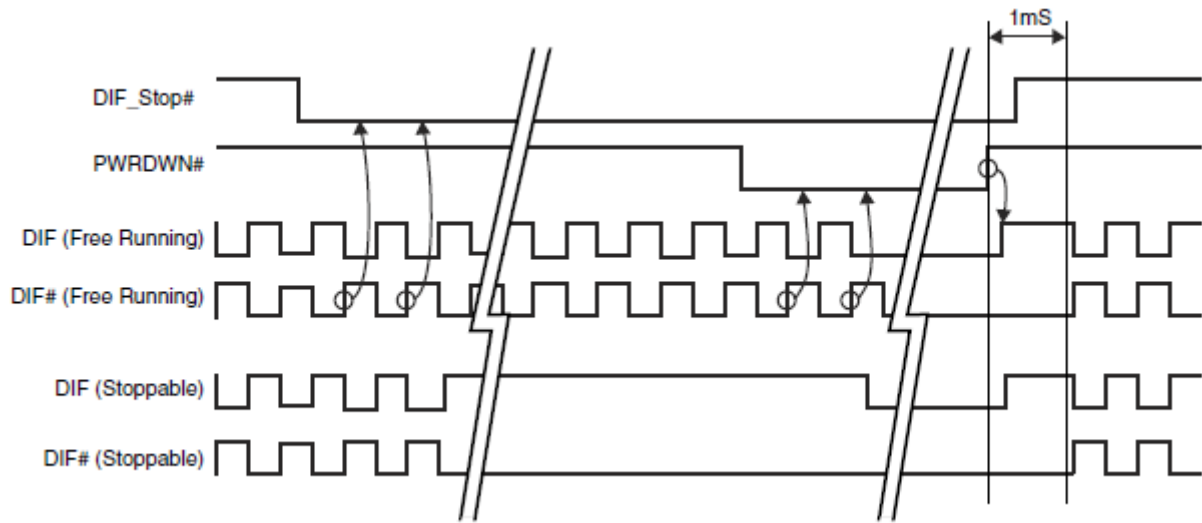
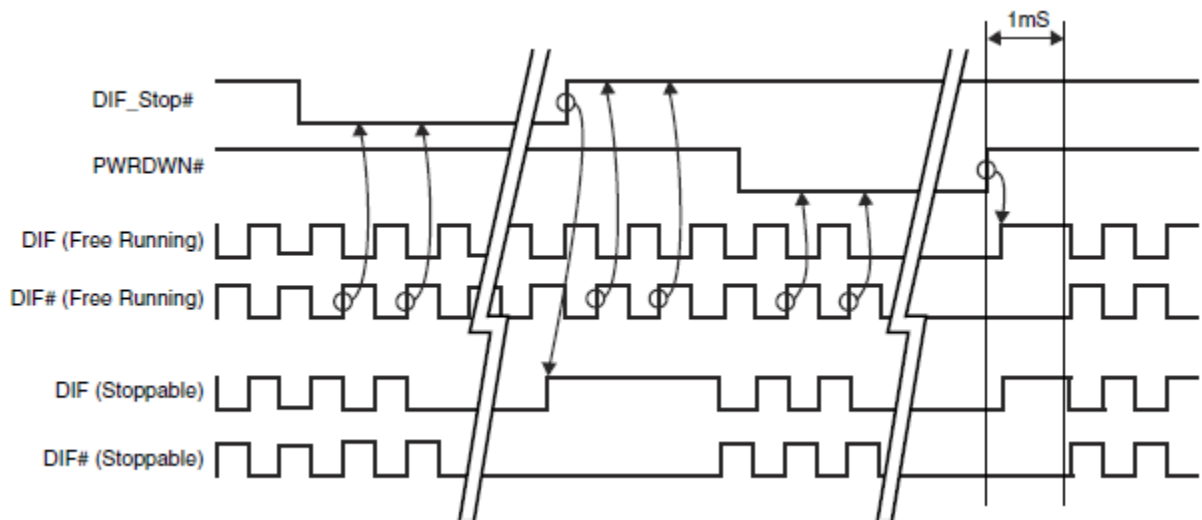
**DIF\_STOP\_3 (Stop\_Mode = Driven, PD\_Mode = Tristate)****DIF\_STOP\_4 (Stop\_Mode = Tristate, PD\_Mode = Tristate)**



Package Outline and Package Dimensions (28-pin, 209 mil SSOP)

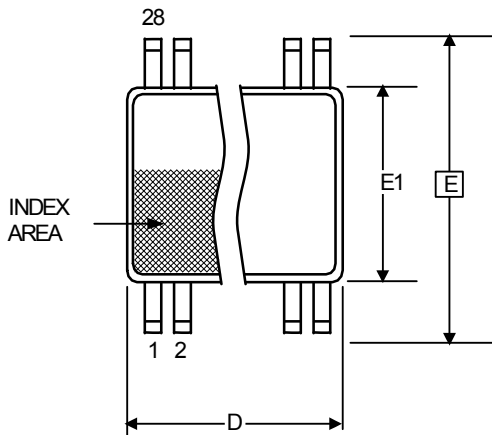

Symbol	Millimeters		Inches	
	Min	Max	Min	Max
A	--	2.00	--	0.079
A1	0.05		0.002	
A2	1.65	1.85	0.065	0.073
b	0.22	0.38	0.009	0.015
C	0.09	0.25	0.0035	0.010
D	9.90	10.50	0.390	0.413
E	7.40	8.20	0.291	0.323
E1	5.00	5.60	0.197	0.220
e	0.65 Basic		0.0256 Basic	
L	0.55	0.95	0.022	0.037
$\alpha$	0°	8°	0°	8°
aaa	--	0.10	--	0.004

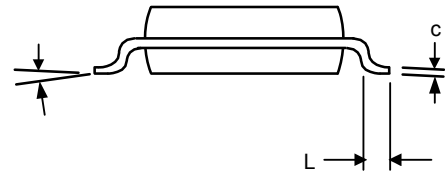
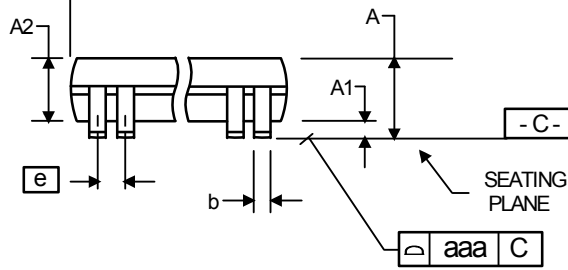

## Package Outline and Package Dimensions (28-pin TSSOP, 4.40mm Body, 0.65 Pitch)

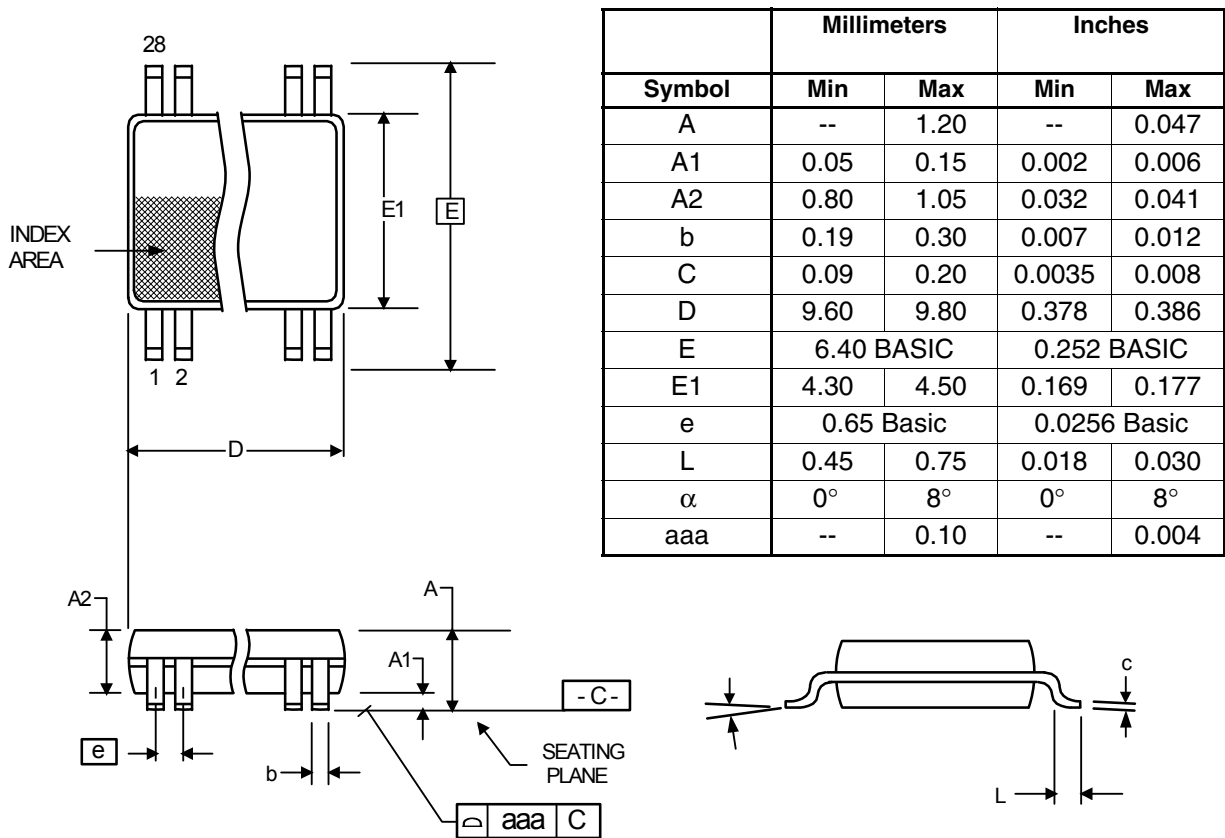

## Ordering Information

Part / Order Number	Shipping Packaging	Package	Temperature
9DB423BFLF	Tubes	28-pin SSOP	0 to +70°C
9DB423BFLFT	Tape and Reel	28-pin SSOP	0 to +70°C
9DB423BGLF	Tubes	28-pin TSSOP	0 to +70°C
9DB423BGLFT	Tape and Reel	28-pin TSSOP	0 to +70°C

"LF" suffix to the part number are the Pb-Free configuration and are RoHS compliant.

"B" is the device revision designator (will not correlate with the datasheet revision).

While the information presented herein has been checked for both accuracy and reliability, Integrated Device Technology (IDT) assumes no responsibility for either its use or for the infringement of any patents or other rights of third parties, which would result from its use. No other circuits, patents, or licenses are implied. This product is intended for use in normal commercial applications. Any other applications such as those requiring extended temperature range, high reliability, or other extraordinary environmental requirements are not recommended without additional processing by IDT. IDT reserves the right to change any circuitry or specifications without notice. IDT does not authorize or warrant any IDT product for use in life support devices or critical medical instruments.

## Revision History

Rev.	Issue Date	Description	Page #
A	9/30/2008	1. Updated Electrical Characteristics to add propagation delay and phase noise information. 2. Corrected SMBus to reference pin numbers for 423 instead of 823 device. 3. Removed references to OE controls that are not present on 423. 4. Added SMBus electrical characteristics 5. Added foot note about DIF input running in order for the SMBus interface to work 6. Added foot note to Byte 1 about functionality of OE bits and OE pins. 7. Corrected Block Diagram with proper OE pins indicated and PD and DIF_STOP# pins added 8. Updated clock periods to reflect +/-100ppm input clock tolerance (CK410B+/CK420BQ/CK505). 9. Changed SRC_Stop references to DIF_Stop references for consistency.	Various
B	2/3/2010	1. Corrected Polarity of PD pin when OE_INV = 1. PD is always active low (or PD#). This is a difference from the 9DB803D.	Various
C	1/27/2011	Updated Termination Figure 4	10
D	5/9/2011	1. Update pin 1 pin-name and pin description from VDD to VDDR. This highlights that optimal performance is obtained by treating VDDR as in analog pin. This is a document update only, there is no silicon change.	Various
E	9/18/2012	1. Updated Byte 2, bits 1, 2, 5 and 6 per char review. Outputs can be programmed with Byte 2 to be Stoppable or Free-Run with DIF_Stop pin, not the OE pins. 2. Re-created datasheet in FrameMaker.	Various



## IMPORTANT NOTICE AND DISCLAIMER

RENESAS ELECTRONICS CORPORATION AND ITS SUBSIDIARIES (“RENESAS”) PROVIDES TECHNICAL SPECIFICATIONS AND RELIABILITY DATA (INCLUDING DATASHEETS), DESIGN RESOURCES (INCLUDING REFERENCE DESIGNS), APPLICATION OR OTHER DESIGN ADVICE, WEB TOOLS, SAFETY INFORMATION, AND OTHER RESOURCES “AS IS” AND WITH ALL FAULTS, AND DISCLAIMS ALL WARRANTIES, EXPRESS OR IMPLIED, INCLUDING, WITHOUT LIMITATION, ANY IMPLIED WARRANTIES OF MERCHANTABILITY, FITNESS FOR A PARTICULAR PURPOSE, OR NON-INFRINGEMENT OF THIRD PARTY INTELLECTUAL PROPERTY RIGHTS.

These resources are intended for developers skilled in the art designing with Renesas products. You are solely responsible for (1) selecting the appropriate products for your application, (2) designing, validating, and testing your application, and (3) ensuring your application meets applicable standards, and any other safety, security, or other requirements. These resources are subject to change without notice. Renesas grants you permission to use these resources only for development of an application that uses Renesas products. Other reproduction or use of these resources is strictly prohibited. No license is granted to any other Renesas intellectual property or to any third party intellectual property. Renesas disclaims responsibility for, and you will fully indemnify Renesas and its representatives against, any claims, damages, costs, losses, or liabilities arising out of your use of these resources. Renesas' products are provided only subject to Renesas' Terms and Conditions of Sale or other applicable terms agreed to in writing. No use of any Renesas resources expands or otherwise alters any applicable warranties or warranty disclaimers for these products.

(Rev.1.0 Mar 2020)

### Corporate Headquarters

TOYOSU FORESIA, 3-2-24 Toyosu,  
Koto-ku, Tokyo 135-0061, Japan  
[www.renesas.com](http://www.renesas.com)

### Contact Information

For further information on a product, technology, the most up-to-date version of a document, or your nearest sales office, please visit:  
[www.renesas.com/contact/](http://www.renesas.com/contact/)

### Trademarks

Renesas and the Renesas logo are trademarks of Renesas Electronics Corporation. All trademarks and registered trademarks are the property of their respective owners.