

# SN54F623, SN74F623 OCTAL BUS TRANSCEIVERS WITH 3-STATE OUTPUTS

SDFS087 – MARCH 1987 – REVISED OCTOBER 1993

- Local Bus-Latch Capability
- Noninverting Logic
- Package Options Include Plastic Small-Outline Packages, Ceramic Chip Carriers, and Standard Plastic and Ceramic 300-mil DIPs

## description

These octal bus transceivers are designed for asynchronous communication between data buses. The control function implementation allows for maximum flexibility in timing.

These devices allow data transmission from the A bus to the B bus or from the B bus to the A bus depending upon the logic levels at the output enable (OEAB and  $\overline{\text{OEBA}}$ ) inputs.

The output-enable inputs can be used to disable the device so that the buses are effectively isolated. The dual-enable configuration gives the transceivers the capability of storing data by simultaneously enabling OEAB and  $\overline{\text{OEBA}}$ . Each output reinforces its input in this configuration. When both OEAB and  $\overline{\text{OEBA}}$  are enabled and all other data sources to the two sets of bus lines are at high impedance, both sets of bus lines (16 in all) will remain at their last states.

The SN54F623 is characterized for operation over the full military temperature range of  $-55^{\circ}\text{C}$  to  $125^{\circ}\text{C}$ . The SN74F623 is characterized for operation from  $0^{\circ}\text{C}$  to  $70^{\circ}\text{C}$ .

SN54F623 . . . J PACKAGE  
SN74F623 . . . DW OR N PACKAGE  
(TOP VIEW)

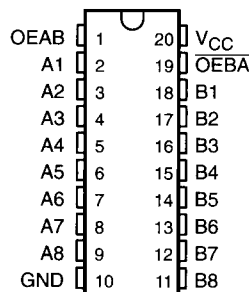

SN54F623 . . . FK PACKAGE  
(TOP VIEW)

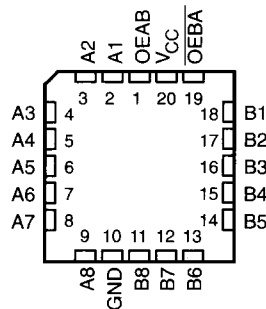

FUNCTION TABLE

INPUTS		OPERATION
$\overline{\text{OEBA}}$	OEAB	
L	L	B data to A bus
L	H	B data to A bus, A data to B bus
H	L	isolation
H	H	A data to B bus

# SN54F623, SN74F623 OCTAL BUS TRANSCEIVERS WITH 3-STATE OUTPUTS

SDFS087 - MARCH 1987 - REVISED OCTOBER 1993

## logic symbol†

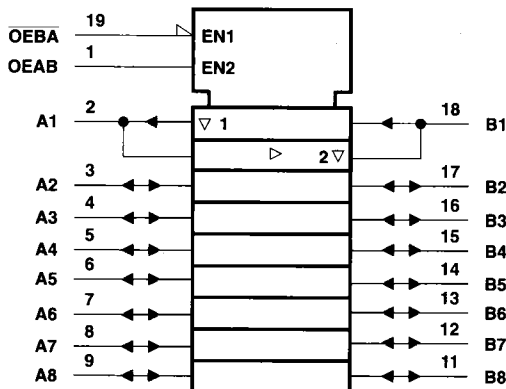

## logic diagram (positive logic)

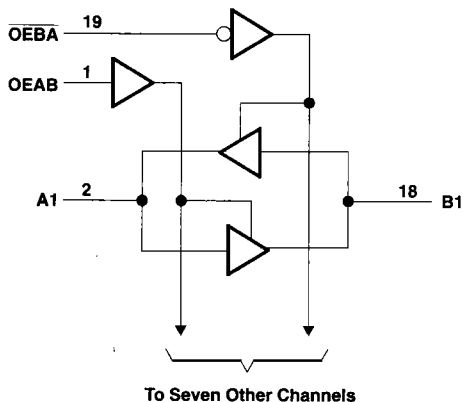

† This symbol is in accordance with ANSI/IEEE Std 91-1984 and IEC Publication 617-12.

## absolute maximum ratings over operating free-air temperature range (unless otherwise noted)‡

Supply voltage range, $V_{CC}$ .....	-0.5 V to 7 V
Input voltage range, $V_I$ (excluding I/O ports) (see Note 1) .....	-1.2 V to 7 V
Input current range, $I_{IK}$ .....	-30 mA to 5 mA
Voltage range applied to any output in the disabled or power-off state .....	-0.5 V to 5.5 V
Voltage range applied to any output in the high state .....	-0.5 V to $V_{CC}$
Current into any output in the low state: SN54F623 (A1-A8) .....	40 mA
SN54F623 (B1-B8) .....	96 mA
SN74F623 (A1-A8) .....	48 mA
SN74F623 (B1-B8) .....	128 mA
Operating free-air temperature range: SN54F623 .....	-55°C to 125°C
SN74F623 .....	0°C to 70°C
Storage temperature range .....	-65°C to 150°C

‡ Stresses beyond those listed under "absolute maximum ratings" may cause permanent damage to the device. These are stress ratings only, and functional operation of the device at these or any other conditions beyond those indicated under "recommended operating conditions" is not implied. Exposure to absolute-maximum-rated conditions for extended periods may affect device reliability.

NOTE 1: The input-voltage ratings may be exceeded provided the input-current ratings are observed.

## recommended operating conditions

		SN54F623			SN74F623			UNIT
		MIN	NOM	MAX	MIN	NOM	MAX	
$V_{CC}$	Supply voltage	4.5	5	5.5	4.5	5	5.5	V
$V_{IH}$	High-level input voltage	2			2			V
$V_{IL}$	Low-level input voltage			0.8			0.8	V
$I_{IK}$	Input clamp current			-18			-18	mA
$I_{OH}$	High-level output current	A1-A8		-3			-3	mA
		B1-B8		-12		-15		
$I_{OL}$	Low-level output current	A1-A8		20		24	mA	
		B1-B8		48		64		
$T_A$	Operating free-air temperature		-55	125		0	70	°C

**SN54F623, SN74F623**  
**OCTAL BUS TRANSCEIVERS**  
**WITH 3-STATE OUTPUTS**

SDFS087 - MARCH 1987 - REVISED OCTOBER 1983

**electrical characteristics over recommended operating free-air temperature range (unless otherwise noted)**

PARAMETER		TEST CONDITIONS		SN54F623		SN74F623		UNIT
				MIN	TYP†	MAX	MIN	
V <sub>IK</sub>		V <sub>CC</sub> = 4.5 V,	I <sub>I</sub> = -18 mA	-1.2		-1.2		V
V <sub>OH</sub>	A1-A8	V <sub>CC</sub> = 4.5 V	I <sub>OH</sub> = -1 mA	2.5	3.4	2.5	3.4	V
			I <sub>OH</sub> = -3 mA	2.4	3.3	2.4	3.3	
	B1-B8		I <sub>OH</sub> = -3 mA	2.4	3.3	2.4	3.3	
			I <sub>OH</sub> = -12 mA	2	3.2			
			I <sub>OH</sub> = -15 mA			2	3.1	
Any output		V <sub>CC</sub> = 4.75 V,	I <sub>OH</sub> = -1 mA to -3 mA			2.7		
V <sub>OL</sub>	A1-A8	V <sub>CC</sub> = 4.5 V	I <sub>OL</sub> = 20 mA	0.3	0.5			V
			I <sub>OL</sub> = 24 mA			0.35	0.5	
	B1-B8		I <sub>OL</sub> = 48 mA	0.38	0.55			
			I <sub>OL</sub> = 64 mA			0.42	0.55	
I <sub>I</sub>	A and B ports	V <sub>CC</sub> = 5.5 V	V <sub>I</sub> = 5.5 V	1		1		mA
	OEAB or OEBA		V <sub>I</sub> = 7 V	0.1		0.1		
I <sub>IH</sub> ‡	A and B ports	V <sub>CC</sub> = 5.5 V,	V <sub>I</sub> = 2.7 V	70		70		μA
	OEAB or OEBA			20		20		
I <sub>IL</sub> ‡	A and B ports	V <sub>CC</sub> = 5.5 V,	V <sub>I</sub> = 0.5 V	-0.65		-0.65		mA
	OEAB or OEBA			-0.6		-0.6		
I <sub>OS</sub> §	A1-A8	V <sub>CC</sub> = 5.5 V,	V <sub>O</sub> = 0	-60	-150	-60	-150	mA
	B1-B8			-100	-225	-100	-225	
I <sub>CCH</sub>	V <sub>CC</sub> = 5.5 V,		Any output = 4.5 V	110	140	110	140	mA
I <sub>CCL</sub>	V <sub>CC</sub> = 5.5 V		OEAB or OEBA = 4.5 V, A1-A8 = GND	110	140	110	140	mA
I <sub>CCZ</sub>	V <sub>CC</sub> = 5.5 V		OEBA or A1-A8 = 4.5 V, OEAB = GND	99	130	99	130	mA

† All typical values are at V<sub>CC</sub> = 5 V, T<sub>A</sub> = 25°C.

‡ For I/O ports, the parameters I<sub>IH</sub> and I<sub>IL</sub> include the off-state output current.

§ Not more than one output should be shorted at a time, and the duration of the short circuit should not exceed one second.

**SN54F623, SN74F623**  
**OCTAL BUS TRANSCEIVERS**  
**WITH 3-STATE OUTPUTS**

SDFS087 - MARCH 1987 - REVISED OCTOBER 1993

**switching characteristics (see Note 2)**

PARAMETER	FROM (INPUT)	TO (OUTPUT)	V <sub>CC</sub> = 5 V, C <sub>L</sub> = 50 pF, R <sub>L</sub> = 500 Ω, T <sub>A</sub> = 25°C			V <sub>CC</sub> = 4.5 V to 5.5 V, C <sub>L</sub> = 50 pF, R <sub>L</sub> = 500 Ω, T <sub>A</sub> = MIN to MAX †				UNIT
			'F623			SN54F623		SN74F623		
			MIN	TYP	MAX	MIN	MAX	MIN	MAX	
t <sub>PLH</sub>	A	B	1.2	3.6	5.5	1.1	6.8	1.2	6.5	ns
t <sub>PHL</sub>			2.2	4.6	7	1.6	8	1.7	7.5	
t <sub>PLH</sub>	B	A	1.2	3.6	5.5	1.1	6.8	1.2	6.5	ns
t <sub>PHL</sub>			1.7	4.1	6.5	1.6	8	1.7	7.5	
t <sub>PZH</sub>	OEBA	A	3.1	8.1	10.5	2.7	12.4	3.1	12	ns
t <sub>PZL</sub>			2.8	7.1	9.5	2.5	10.3	2.8	10	
t <sub>PHZ</sub>	OEBA	A	1.7	4.1	6.5	1.6	8.3	1.7	7.5	ns
t <sub>PLZ</sub>			1.7	4.1	6.5	1.5	7.4	1.7	7	
t <sub>PZH</sub>	OEAB	B	2.8	7.6	10	2.7	12	2.8	11.5	ns
t <sub>PZL</sub>			2.8	6.6	9	2.8	10	2.9	9.5	
t <sub>PHZ</sub>	OEAB	B	2.2	5.6	8.5	1.9	10	2.2	10	ns
t <sub>PLZ</sub>			3.2	6.6	9	3.1	10.7	3.2	10	

† For conditions shown as MIN or MAX, use the appropriate value specified under recommended operating conditions.

NOTE 2: Load circuits and waveforms are shown in Section 1.