



SANYO Semiconductors

DATA SHEET

STK415-120-E

Thick-Film Hybrid IC
— 2-Channel Power Switching
Audio Power IC, 80W+80W

Overview

The STK415-120-E is a class H audio power amplifier hybrid IC that features a built-in power supply switching circuit. This IC provides high efficiency audio power amplification by controlling (switching) the supply voltage supplied to the power devices according to the detected level of the input audio signal.

Applications

- Audio power amplifiers.

Features

- Pin-to-pin compatible outputs ranging from 80W to 180W.
- Can be used to replace the STK416-100 series (3-channel models) and the class-AB series (2, 3-channel models) due to its pin compatibility.
- Pure complementary construction by new Darlington power transistors
- Output load impedance: $R_L = 8\Omega$ to 4Ω supported
- Using insulated metal substrate that features superlative heat dissipation characteristics that are among the highest in the industry.

Series Models

	STK415-090-E	STK415-100-E	STK415-120-E	STK415-130-E	STK415-140-E
Output 1 (10%/1kHz)	80W×2ch	90W×2ch	120W×2ch	150W×2ch	180W×2ch
Output 2 (0.8%/20Hz to 20kHz)	50W×2ch	60W×2ch	80W×2ch	100W×2ch	120W×2ch
Max. rated V_H (quiescent)	±60V	±65V	±73V	±80V	±80V
Max. rated V_L (quiescent)	±41V	±42V	±45V	±46V	±51V
Recommended operating V_H (8Ω)	±37V	±39V	±46V	±51V	±52V
Recommended operating V_L (8Ω)	±27V	±29V	±32V	±34V	±32V
Dimensions (excluding pin height)	64.0mm×31.1mm×9.0mm				

■ Any and all SANYO Semiconductor Co.,Ltd. products described or contained herein are, with regard to "standard application", intended for the use as general electronics equipment (home appliances, AV equipment, communication device, office equipment, industrial equipment etc.). The products mentioned herein shall not be intended for use for any "special application" (medical equipment whose purpose is to sustain life, aerospace instrument, nuclear control device, burning appliances, transportation machine, traffic signal system, safety equipment etc.) that shall require extremely high level of reliability and can directly threaten human lives in case of failure or malfunction of the product or may cause harm to human bodies, nor shall they grant any guarantee thereof. If you should intend to use our products for applications outside the standard applications of our customer who is considering such use and/or outside the scope of our intended standard applications, please consult with us prior to the intended use. If there is no consultation or inquiry before the intended use, our customer shall be solely responsible for the use.

■ Specifications of any and all SANYO Semiconductor Co.,Ltd. products described or contained herein stipulate the performance, characteristics, and functions of the described products in the independent state, and are not guarantees of the performance, characteristics, and functions of the described products as mounted in the customer's products or equipment. To verify symptoms and states that cannot be evaluated in an independent device, the customer should always evaluate and test devices mounted in the customer's products or equipment.

STK415-120-E

Specifications

Absolute maximum ratings at $T_a=25^\circ\text{C}$ (excluding rated temperature items), $T_c=25^\circ\text{C}$ unless otherwise specified

Parameter	Symbol	Conditions	Ratings	Unit
V_H maximum quiescent supply voltage 1	V_H max (1)	When no signal	± 73	V
V_H maximum supply voltage 2	V_H max (2)	$R_L \geq 6\Omega$	± 65	V
V_H maximum supply voltage 3	V_H max (3)	$R_L \geq 4\Omega$	± 52	V
V_L maximum quiescent supply voltage 1	V_L max (1)	When no signal	± 45	V
V_L maximum supply voltage 2	V_L max (2)	$R_L \geq 6\Omega$	± 42	V
V_L maximum supply voltage 3	V_L max (3)	$R_L \geq 4\Omega$	± 32	V
Maximum voltage between V_H and V_L *4	V_H-V_L max	No loading	60	V
Standby pin maximum voltage	V_{st} max		-0.3 to +5.5	V
Thermal resistance	θ_{j-c}	Per power transistor	1.6	$^\circ\text{C/W}$
Junction temperature	T_j max	Both the T_j max and T_c max conditions must be met.	150	$^\circ\text{C}$
IC substrate operating temperature	T_c max		125	$^\circ\text{C}$
Storage temperature	T_{stg}		-30 to +125	$^\circ\text{C}$
Allowable load shorted time *3	t_s	$V_H=\pm 46\text{V}$, $V_L=\pm 32\text{V}$, $R_L=8\Omega$, $f=50\text{Hz}$, $P_O=80\text{W}$, 1-channel active	0.3	s

Electrical Characteristics at $T_c=25^\circ\text{C}$, $R_L=8\Omega$ (non-inductive load), $R_g=600\Omega$, $V_G=40\text{dB}$, $V_Z=15\text{V}$

Parameter	Symbol	Conditions *1						Ratings			unit
		V (V)	f (Hz)	P_O (W)	THD (%)			min	typ	max	
Output power	P_O (1)	V_H V_L	± 46 ± 32	20 to 20k		0.8		80			W
	P_O (2)	V_H V_L	± 36 ± 26	1k		0.8	$R_L=4\Omega$	80			
Total harmonic distortion	THD	V_H V_L	± 46 ± 32	20 to 20k	80				0.4		%
Frequency characteristics	f_L, f_H	V_H V_L	± 46 ± 32		1.0		+0 -3dB	20 to 50k			Hz
Input impedance	r_i	V_H V_L	± 46 ± 32	1k	1.0				55		$\text{k}\Omega$
Output noise voltage *2	V_{NO}	V_H V_L	± 54 ± 35				$R_g=2.2\text{k}\Omega$			1.0	mVrms
Quiescent current	I_{CCO}	V_H	± 54				$R_L=\infty$			30	mA
		V_L	± 35						100		
Output neutral voltage	V_N	V_H V_L	± 54 ± 35					-70	0	+70	mV
Pin 17 voltage when standby ON *7	VST ON	V_H V_L	± 46 ± 32				Standby		0	0.6	V
Pin 17 voltage when standby OFF *7	VST OFF	V_H V_L	± 46 ± 32				Operating	2.5	3.0		V

[Remarks]

- *1: Unless otherwise specified, use a constant-voltage power supply to supply power when inspections are carried out.
- *2: The output noise voltage values shown are peak values read with a VTVM. However, an AC stabilized (50Hz) power supply should be used to minimize the influence of AC primary side flicker noise on the reading.
- *3: Use the designated transformer power supply circuit shown in the figure below for the measurements of allowable load shorted time and output noise voltage.
- *4: Design circuits so that $(|V_H|-|V_L|)$ is always less than 40V when switching the power supply with the load connected.
- *5: Set up the V_L power supply with an offset voltage at power supply switching (V_L-V_O) of about 8V as an initial target.
- *6: Please connect -Pre V_{CC} pin (#5 pin) with the stable minimum voltage and connect so that current does not flow in by reverse bias.
- *7: Use the standby pin (pin 17) so that the applied voltage never exceeds the maximum rating.
The power amplifier is turned on by applying +2.5V to +5.5V to the standby pin (pin 17).
- *8: Thermal design must be implemented based on the conditions under which the customer's end products are expected to operate on the market.
- *9: A thermoplastic adhesive resin is used for this hybrid IC.

STK415-120-E

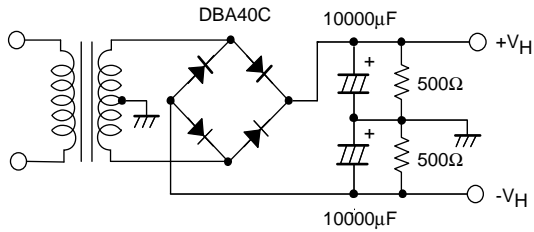

Designated transformer power supply
(MG-250 equivalent)

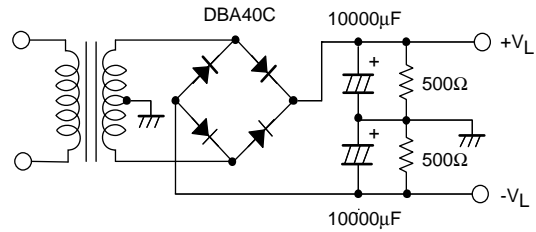

Designated transformer power supply
(MG-200 equivalent)

Package Dimensions

unit:mm (typ)

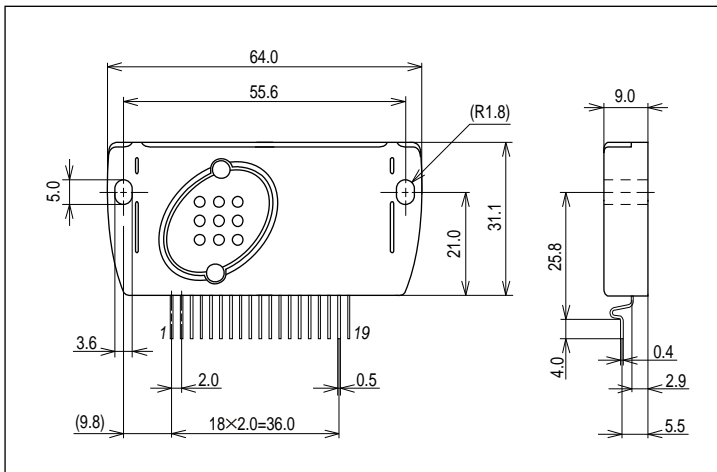

Internal Equivalent Circuit

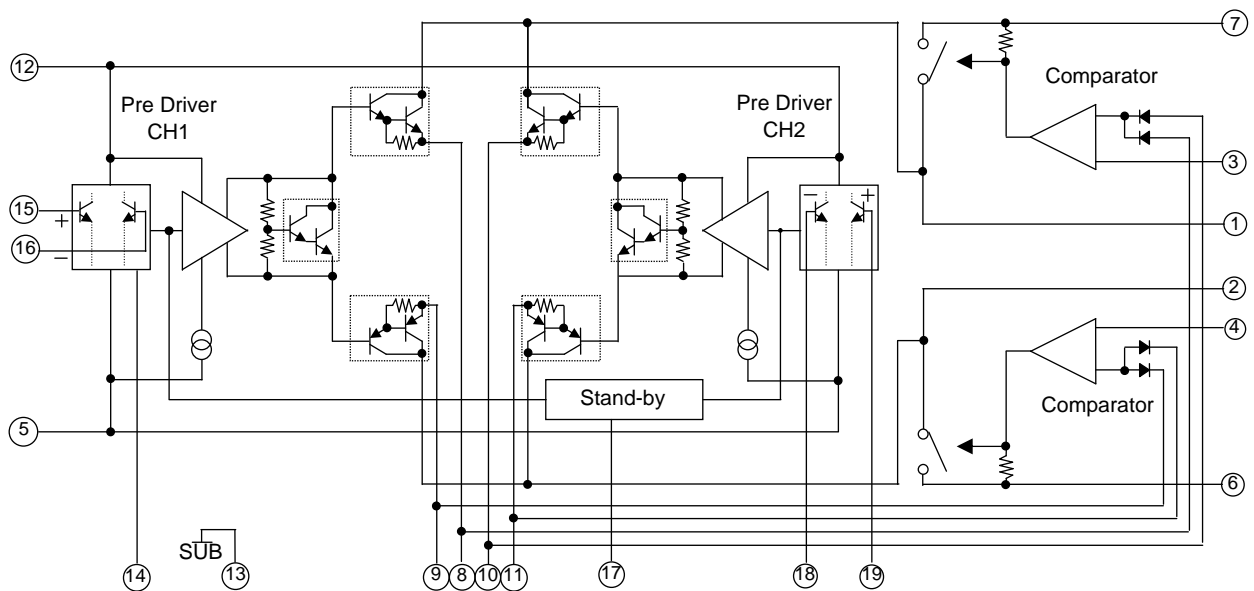

STK415-120-E

Application Circuit Example

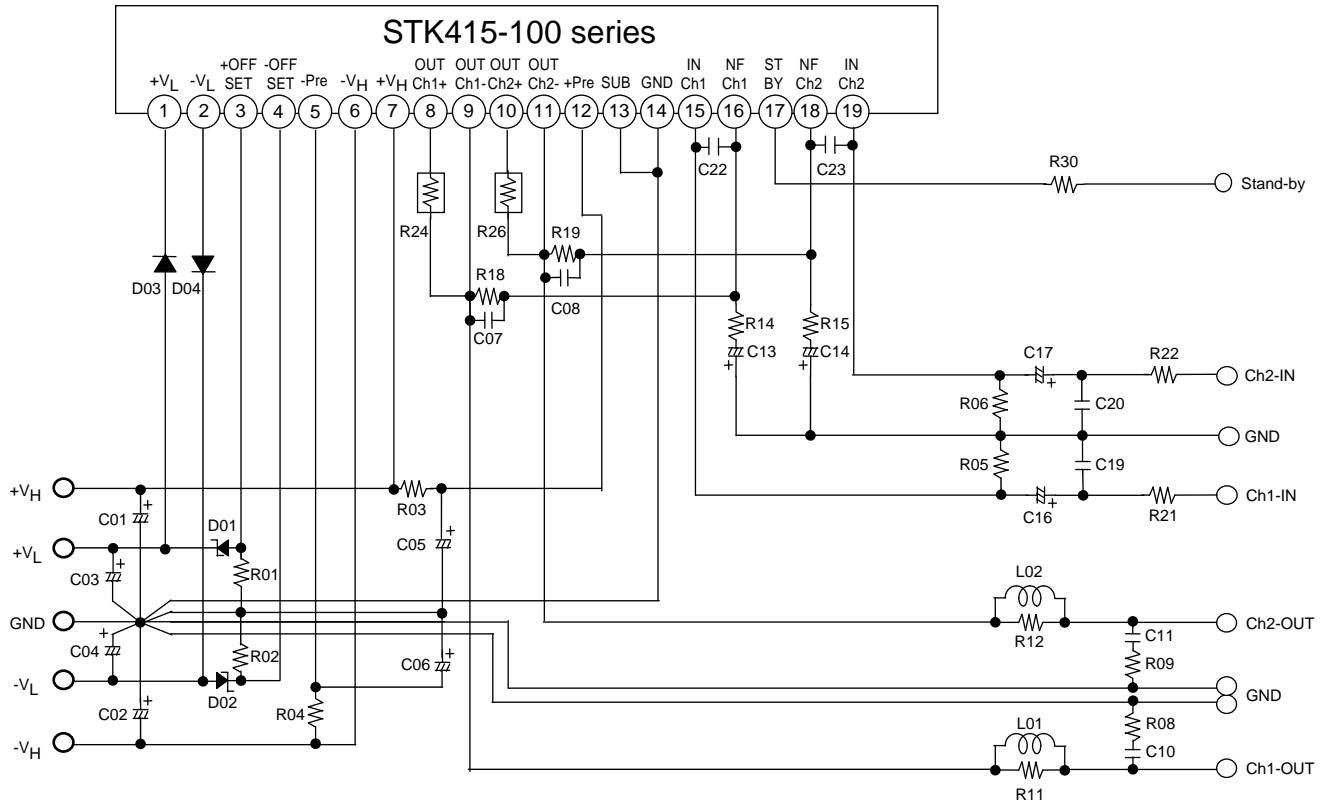

STK415-120-E

Recommended Values for Application Parts (for the test circuit)

Symbol	Recommended Value	Description	Larger than Recommended Value	Smaller than Recommended Value
R01, R02	1.5kΩ	Determine the current flowing into the power switching circuit (comparator), (3mA to 10mA at V_H power switching)	Power holding circuit remains active at lower frequencies.	Power switching circuit activates at higher frequencies.
R03, R04	100Ω/1W	Ripple filtering resistors (Used with C05 and C06 to form a ripple filter.)	Decreased pass-through current at high frequencies.	Increased pass-through current at high frequencies.
R05, R06	56kΩ	Input bias resistors (Virtually determine the input impedance.)	VN offset (Ensure R05=R18, R06=R19 when changing.)	
R08, R09	4.7Ω/1W	Oscillation prevention resistor	-	-
R11, R12	4.7Ω	Oscillation prevention resistor	-	-
R14, R15	560Ω	Used with R18 and R19 to determine the voltage gain VG. (VG should desirably be determined by the R14 and R15 value.)	Likely to oscillate (VG<40dB)	None
R18, R19	56kΩ	Used with R14 and R15 to determine the voltage gain VG.	-	-
R21, R22	1kΩ	Input filtering resistor	-	-
R24, R26	0.22Ω±10%, 5W	Output emitter resistors (Use of cement resistor is desirable)	Decrease in maximum output power	Likely to cause thermal-runaway.
R30	Remarks *7	Use a limiting resistor according to the voltage applied to the standby pin so that it remains within the rating.		
C01, C02	100μF/ 100V	Oscillation prevention capacitors. • Insert the capacitors as close to the IC as possible to decrease the power impedance for reliable IC operation (use of electrolytic capacitors are desirable).	-	-
C03, C04	100μF/ 50V	Oscillation prevention capacitors. • Insert the capacitors as close to the IC as possible to decrease the power impedance for reliable IC operation (use of electrolytic capacitors are desirable).	-	-
C05, C06	100μF/ 100V	Decoupling capacitors. Eliminate ripple components that pass into the input side from the power line. (Used with R03 and R04 to form a ripple filter.)	Increase in ripple components that pass into the input side from the power line.	
C07, C08	3pF	Oscillation prevention capacitor	Likely to oscillate	
C10, C11	0.1μF	Oscillation prevention capacitor (Mylar capacitors are recommended.)	Likely to oscillate	
C13, C14	22μF/ 10V	NF capacitor (Changes the low cutoff frequency; $ex/f_L=1/2\pi \bullet C13 \bullet R14$)	Increase in low-frequency voltage gain, with higher pop noise at power-on.	Decrease in low-frequency voltage gain
C16, C17	2.2μF/ 50V	Input coupling capacitor (block DC current)	-	-
C19, C20	470pF	Input filter capacitor (Used with R21 and R22 to form a filter that suppresses high-frequency noises.)	-	-
C22, C23	100pF	Oscillation prevention capacitor	Likely to oscillate.	
D01, D02	15V	Determine the offset voltage at $V_L \leftrightarrow V_H$ power.	Decreased distortion at power switching time	Increased distortion at power switching time.
D03, D04	3A/60V	Reverse current prevention diodes (FRD is recommended.)	-	-
L01, L02	3μH	Oscillation prevention inductance	None	Likely to oscillate.

STK415-120-E

Sample PCB Trace Pattern

STK415-100-E-Sr/STK416-100-E-Sr PCB PARTS LIST

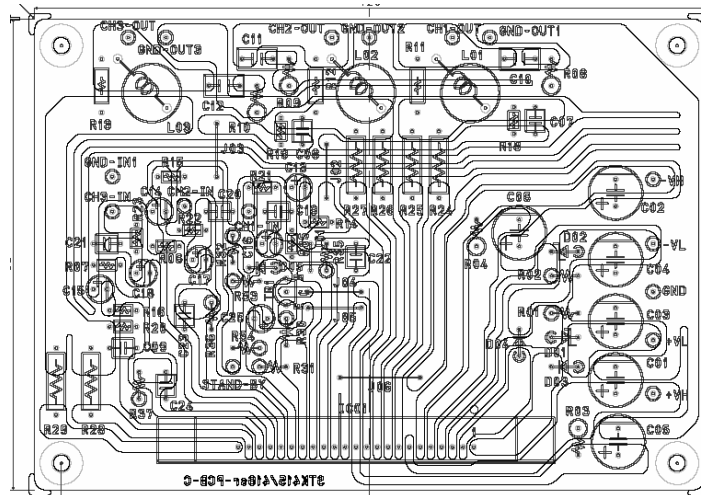

Parts List

STK415, 416-100Sr PCB Parts List

PCB No.	PARTS	RATING	STK415 (416) -090-E, -100-E, -120-E, 130-E	STK415-140-E
R01, R02	-	ERX1SJ***	1.5kΩ, 1W	1.5kΩ, 1W
R03, R04	100Ω, 1W	ERG1SJ101	enabled	enabled
R05, R06, (R07), R18, R19, (R20)	56kΩ, 1/6W	RN16S563FK	enabled	enabled
R08, R09, (R10)	4.7Ω, 1W	ERX1SJ4R7	enabled	enabled
R11, R12, (R13)	4.7Ω, 1/4W	RN14S4R7FK	enabled	enabled
R14, R15, (R16)	-	RN16S***FK	560Ω, 1/6W	560Ω, 1/6W
R21, R22, (R23)	1kΩ, 1/6W	RN16S102FK	enabled	enabled
R25, R27, (R29)	0.22Ω±10%, 5W	BPR56CFR22J	Short	Short
R24, R26, (R28)	0.22Ω±10%, 5W	BPR56CFR22J	enabled	enabled
R35, R36, R37	-	-	Short	Short
C01, C02, C05, C06	100μF, 100V	100MV100HC	enabled	enabled
C03, C04	100μF, 50V	50MV100HC	enabled	enabled
C07, C08, (C09)	3pF	DD104-63B3R0K50	enabled	enabled
C10, C11, (C12)	0.1μF, 100V	ECQ-V1H104JZ	enabled	enabled
C13, C14, (C15)	22μF, 10V	10MV220HC	enabled	enabled
C16, C17, (C18)	2.2μF, 50V	50MV2R2HC	enabled	enabled
C19, C20, (C21)	470pF	DD104-63B471K50	enabled	enabled
C22, C23, (C24)	100pF	DD104-63B101K50	enabled	enabled
D01, D02	-	-	GZA15X (SANYO)	GZA18X (SANYO)
D03, D04	IF (AV)=3A/60V		enabled	enabled
L01, L02, (L03)	3μH		enabled	enabled
Stand-By	R30	3.3kΩ, 1/6W	RN16S332FK	enabled
	R32	1kΩ, 1/6W	RN16S102FK	enabled
	R33	33kΩ, 1/6W	RN16S333FK	enabled
	R34	2kΩ, 1/6W	RN16S202FK	enabled
	C25	47μF, 10V	10MV47HC	enabled
	D05	-	GMB01 (Ref.)	enabled
	TR1	-	2SC2274 (Ref.)	enabled
J01	Jumper	20mm	enabled	enabled
J02, J03, J06	Jumper	10mm	enabled	enabled
J04, J05	Jumper	7mm	enabled	enabled

(*1) STK416-100Sr (3ch AMP) doesn't mount parts of ().

STK415-120-E

Pin Assignments

[STK433-000/-100/-200 Sr & STK415/416-100 Sr Pin Layout]

2ch class-AB		1	2	3	4	5	6	7	8	9	10	11	12	13	14	15									
		2ch classAB/2.00mm																							
STK433-030-E 30W/JEITA		-	-	+	O	O	O	O	+		I	N	S	N	I										
STK433-040-E 40W/JEITA		P	V	V	U	U	U	U	P	S	G	N	F	T	F	N									
STK433-060-E 50W/JEITA		R	C	C	T	T	T	T	R	U	/	/	/	A	/	/									
STK433-070-E 60W/JEITA		E	C	C	/	/	/	/	E	B	D	C	C	N	C	C									
STK433-090-E 80W/JEITA					C	C	C	C	•		H	H	D	H	H										
STK433-100-E 100W/JEITA					H	H	H	H	G		1	1		2	2										
STK433-120-E 120W/JEITA					1	1	2	2	N				B												
STK433-130-E 150W/JEITA					+	-	+	-	D				Y												
3ch class-AB		1	2	3	4	5	6	7	8	9	10	11	12	13	14	15	16	17	18	19					
		3ch classAB/2.00mm																							
STK433-230A-E 30W/JEITA		-	-	+	O	O	O	O	+		I	N	S	N	I	I	N	O	O						
STK433-240A-E 40W/JEITA		P	V	V	U	U	U	U	P	S	G	N	F	T	F	N	F	U	U						
STK433-260A-E 50W/JEITA		R	C	C	T	T	T	T	R	U	/	/	A	/	/	/	/	T	T						
STK433-270-E 60W/JEITA		E	C	C	/	/	/	/	E	B	D	C	C	N	C	C	C	/	/						
STK433-290-E 80W/JEITA					C	C	C	C	•		H	H	D	H	H	H	H	C	C						
STK433-300-E 100W/JEITA					H	H	H	H	G		1	1		2	2	3	3	H	H						
STK433-320-E 120W/JEITA					1	1	2	2	N				B				3	3							
STK433-330-E 150W/JEITA					+	-	+	-	D				Y				+	-							
2ch class-H		1	2	3	4	5	6	7	8	9	10	11	12	13	14	15	16	17	18	19					
		2ch classH/2.00mm																							
STK415-090-E 80W/JEITA		+	-	+	-	-	+	O	O	O	O	+		I	N	S	N	I							
STK415-100-E 90W/JEITA		V	V	O	O	P	V	V	U	U	U	U	P	S	G	N	F	T	F	N					
STK415-120-E 120W/JEITA		L	L	F	F	R	H	H	T	T	T	T	R	U	/	/	A	/	/						
STK415-130-E 150W/JEITA				F	F	E			/	/	/	/	E	B	D	C	C	N	C	C					
STK415-140-E 180W/JEITA				S	S			C	C	C	C	•		H	H	D	H	H							
				E	E			H	H	H	H	G		1	1		2	2							
				T	T			1	1	2	2	N				B									
								+	-	+	-	D				Y									
3ch class-H		1	2	3	4	5	6	7	8	9	10	11	12	13	14	15	16	17	18	19	20	21	22	23	
		3ch classH/2.00mm																							
STK416-090-E 80W/JEITA		+	-	+	-	-	+	O	O	O	O	+		I	N	S	N	I	I	N	O	O			
STK416-100-E 90W/JEITA		V	V	O	O	P	V	V	U	U	U	U	P	S	G	N	F	T	F	N	F	U	U		
STK416-120-E 120W/JEITA		L	L	F	F	R	H	H	T	T	T	T	R	U	/	/	A	/	/	/	/	T	T		
STK416-130-E 150W/JEITA				F	F	E			/	/	/	/	E	B	D	C	C	N	C	C	/	/			
				S	S			C	C	C	C	•		H	H	D	H	H	H	H	C	C			
				E	E			H	H	H	H	G		1	1		2	2	3	3	H	H			
				T	T			1	1	2	2	N				B				3	3				
								+	-	+	-	D				Y				+	-				

Evaluation Board Characteristics

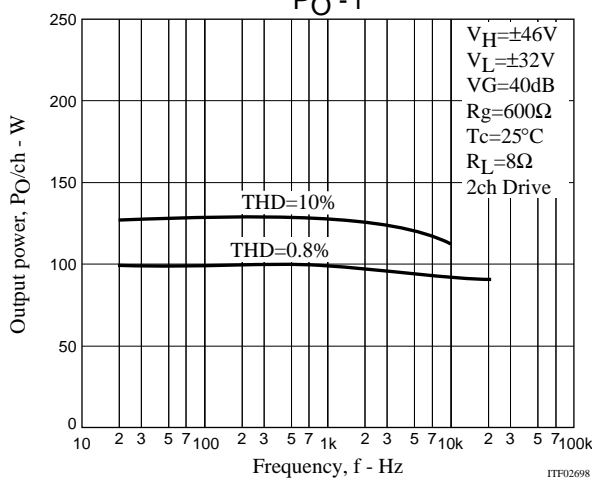
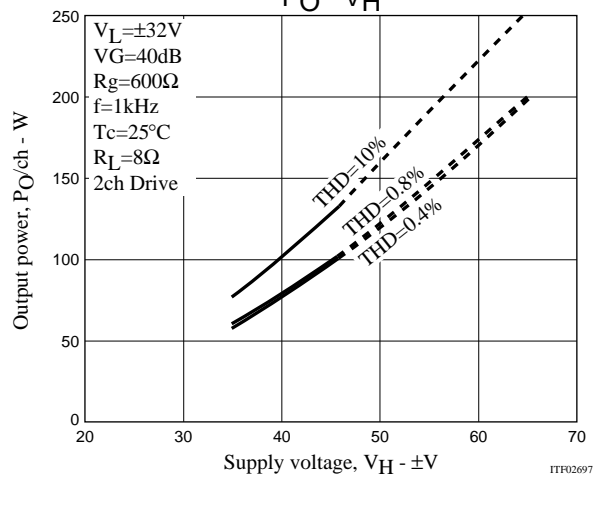
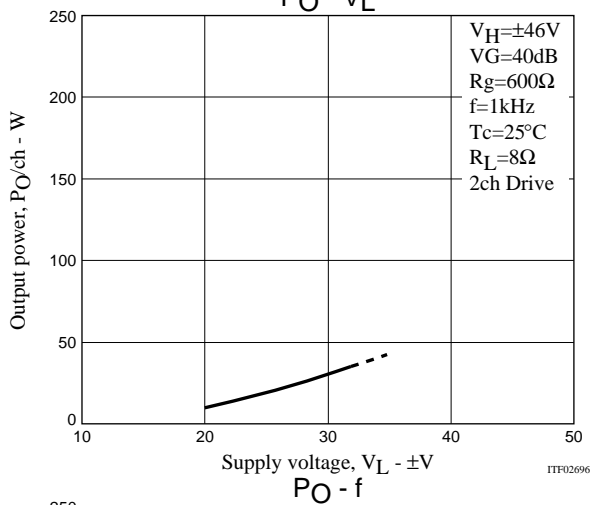
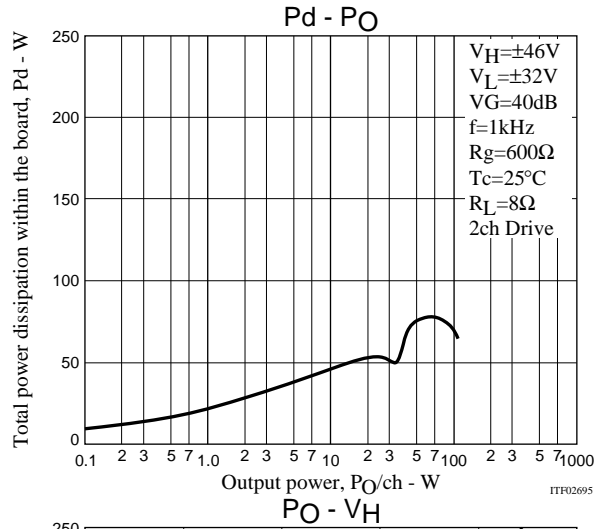
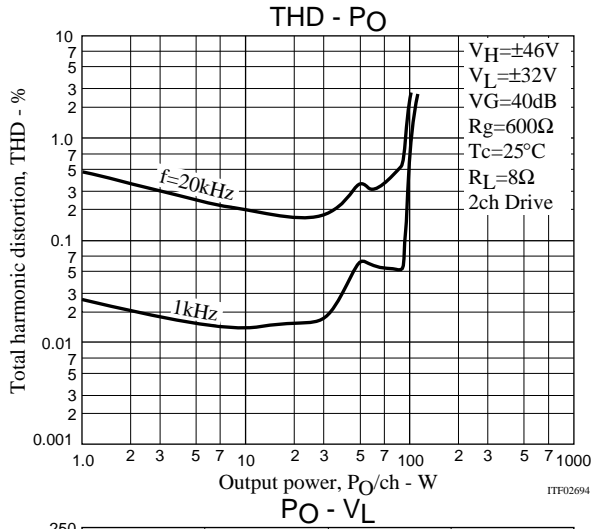

STK415-120-E

[Thermal Design Example for STK415-120-E ($R_L = 8\Omega$)]

The thermal resistance, θ_{c-a} , of the heat sink for total power dissipation, P_d , within the hybrid IC is determined as follows.

Condition 1: The hybrid IC substrate temperature, T_c , must not exceed 125°C .

$$P_d \times \theta_{c-a} + T_a < 125^\circ\text{C} \dots\dots\dots (1)$$

T_a : Guaranteed ambient temperature for the end product

Condition 2: The junction temperature, T_j , of each power transistor must not exceed 150°C .

$$P_d \times \theta_{c-a} + P_d/N \times \theta_{j-c} + T_a < 150^\circ\text{C} \dots\dots\dots (2)$$

N : Number of power transistors

θ_{j-c} : Thermal resistance per power transistor

However, the power dissipation, P_d , for the power transistors shall be allocated equally among the number of power transistors.

The following inequalities result from solving equations (1) and (2) for θ_{c-a} .

$$\theta_{c-a} < (125 - T_a)/P_d \dots\dots\dots (1)'$$

$$\theta_{c-a} < (150 - T_a)/P_d - \theta_{j-c}/N \dots\dots\dots (2)'$$

Values that satisfy these two inequalities at the same time represent the required heat sink thermal resistance.

When the following specifications have been stipulated, the required heat sink thermal resistance can be determined from formulas (1)' and (2)'.
 • Supply voltage V_H, V_L
 • Load resistance R_L
 • Guaranteed ambient temperature T_a

[Example]

When the IC supply voltage, $V_H = \pm 46\text{V}$, $V_L = \pm 32\text{V}$ and R_L is 8Ω , the total power dissipation, P_d , within the hybrid IC, will be a maximum of 77W at 1kHz for a continuous sine wave signal according to the P_d - P_O characteristics. For the music signals normally handled by audio amplifiers, a value of $1/8P_O \text{ max}$ is generally used for P_d as an estimate of the power dissipation based on the type of continuous signal. (Note that the factor used may differ depending on the safety standard used.)

This is:

$$P_d \approx 46.0\text{W} \quad (\text{when } 1/8P_O \text{ max.} = 10\text{W}, P_O \text{ max.} = 80\text{W}).$$

The number of power transistors in audio amplifier block of these hybrid ICs, N , is 4, and the thermal resistance per transistor, θ_{j-c} , is 1.6°C/W . Therefore, the required heat sink thermal resistance for a guaranteed ambient temperature, T_a , of 50°C will be as follows.

$$\begin{aligned} \text{From formula (1)'} \quad \theta_{c-a} &< (125 - 50)/46.0 \\ &< 1.63 \end{aligned}$$

$$\begin{aligned} \text{From formula (2)'} \quad \theta_{c-a} &< (150 - 50)/46.0 - 1.6/4 \\ &< 1.77 \end{aligned}$$

Therefore, the value of 1.63°C/W , which satisfies both of these formulae, is the required thermal resistance of the heat sink.

Note that this thermal design example assumes the use of a constant-voltage power supply, and is therefore not a verified design for any particular user's end product.

STK415-120-E

STK415-100 Series Stand-by control, Mute control, Load-short protection & DC offset protection application

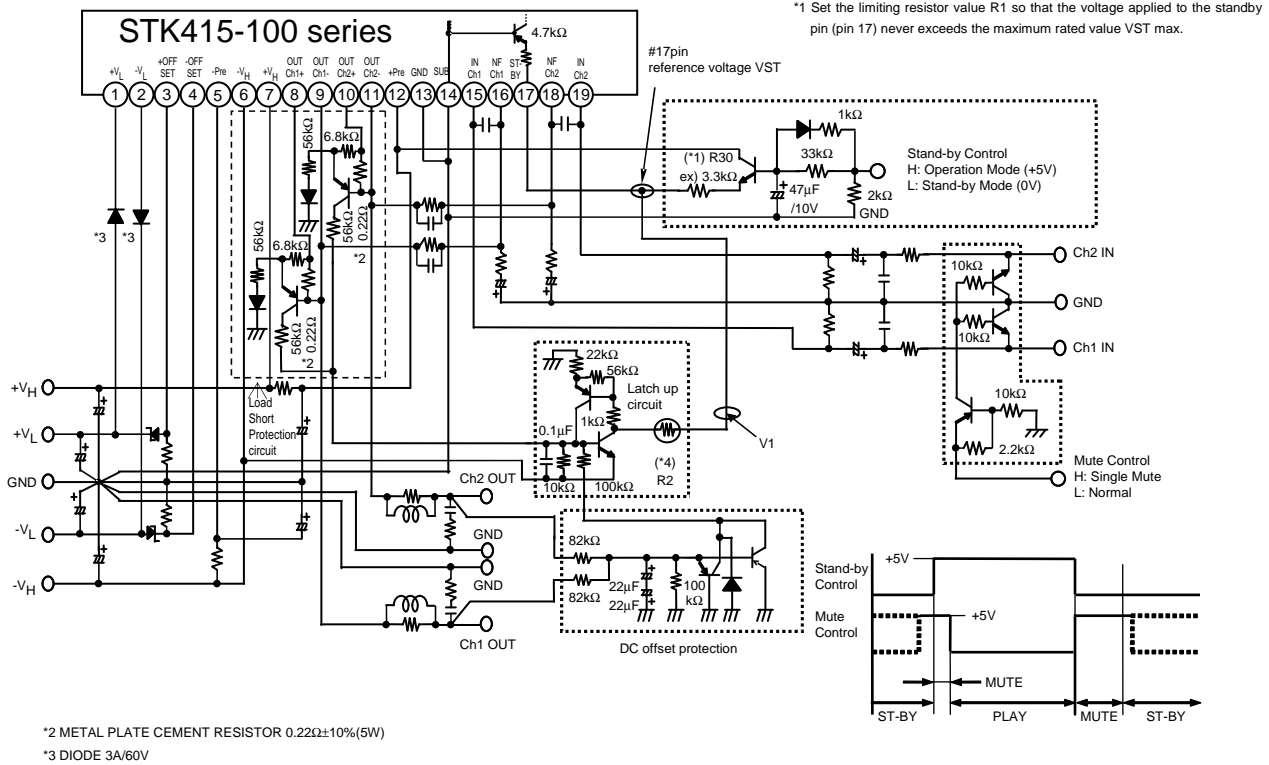

STK415-100 Series Application explanation

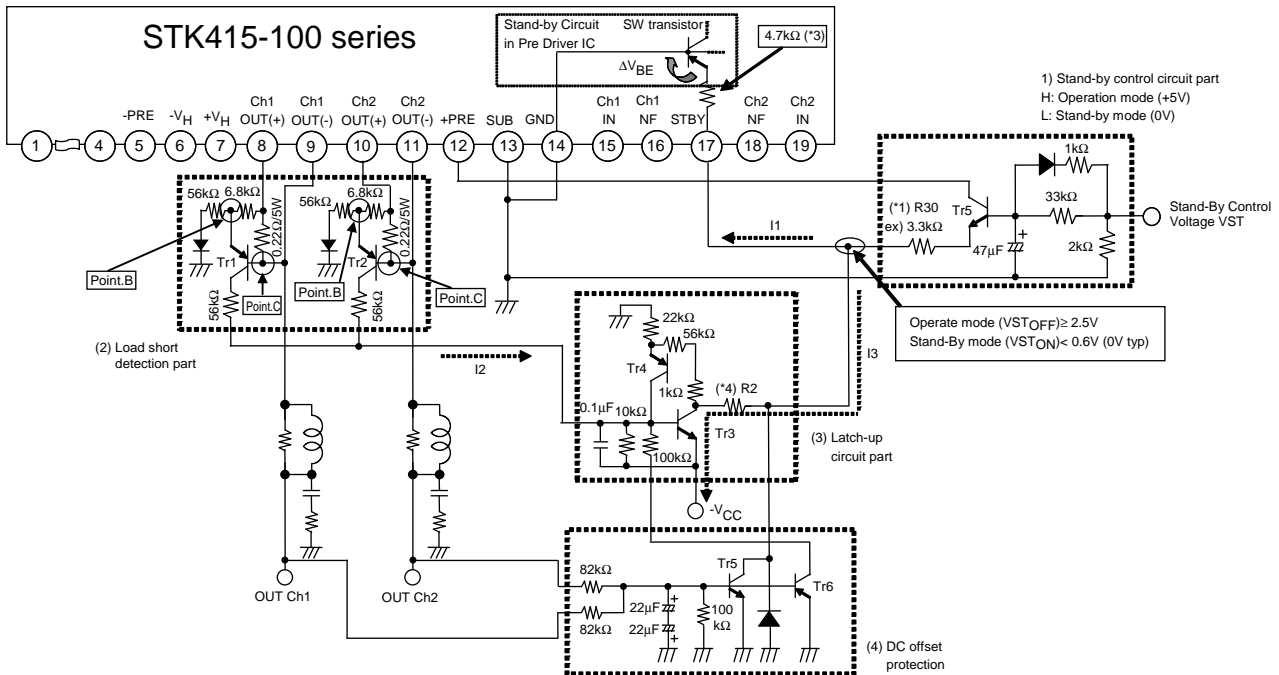

STK415-120-E

The protection circuit application for the STK415-100sr consists of the following blocks (blocks (1) to (4)).

- (1) Standby control circuit block
- (2) Load short-circuit detection block
- (3) Latch-up circuit block
- (4) DC voltage protection block

1) Standby control circuit block

Concerning pin 17 reference voltage VST

<1> Operation mode

The switching transistor of the predriver IC turns on when the pin 17 reference voltage, VST, becomes greater than or equal to 2.5V, placing the amplifier into the operation mode.

Example: When $VST(\text{min.}) = 2.5\text{V}$

I_1 is approximately equal to 0.40mA since $VST = (*2) \times IST + 0.6\text{V} \rightarrow 2.5\text{V} = 4.7\text{k}\Omega \times IST + 0.6\text{V}$.

<2> Standby mode

The switching transistor of the predriver IC turns off when the pin 17 reference voltage, VST, becomes lower than or equal to 0.6V (typ. 0V), placing the amplifier into the standby mode.

Example: When $VST = 0.6\text{V}$

I_1 is approximately equal to 0mA since $VST = (*2) \times IST + 0.6\text{V} \rightarrow 0.6\text{V} = 4.7\text{k}\Omega \times IST + 0.6\text{V}$.

(*1) Limiting resistor

Determine the value of R1 so that the voltage VST applied to the standby pin (pin 17) falls within the rating (+2.5V to 5.5V (typ. 3.0V)).

(*2) The standby control voltage must be supplied from the host including microcontrollers.

(*3) A 4.7k Ω limiting resistor is also incorporated inside the hybrid IC (at pin 17).

2) Load short-circuit detection block

Since the voltage between point B and point C is less than 0.6V in normal operation mode ($V_{BE} < 0.6\text{V}$) and TR1 (or TR2) is not activated, the load short-circuit detection block does not operate.

When a load short-circuit occurs, however, the voltage between point B and point C becomes larger than 0.6V, causing TR1 (or TR2) to turn on ($V_{BE} > 0.6\text{V}$), and current I_2 to flow.

3) Latch-up circuit block

TR3 is activated when I_2 is supplied to the latch-up circuit.

When TR3 turns on and current I_3 starts flowing, VST goes down to 0V (standby mode), protecting the power amplifier.

Since TR3 and TR4 configure a thyristor, once TR3 is activated, the IC is held in the standby mode.

To release the standby mode and reactivate the power amplifier, it is necessary to set the standby control voltage (*2) temporarily low (0V). Subsequently, when the standby control is returned to high, the power amplifier will become active again.

(*4) The I_3 value varies depending on the supply voltage. Determine the value of R2 using the formula below, so that

I_1 is equal to or less than I_3 .

$$I_1 \leq I_3 = V_{CC}/R_2$$

4) DC offset protection block

The DC offset protection circuit is activated when $\pm 0.5\text{V}$ (typ) voltage is applied to either "OUT CH1" or "OUT CH2," and the hybrid IC is shut down (standby mode).

To release the IC from the standby mode and reactivate the power amplifier, it is necessary to set the standby control voltage temporarily low (0V).

Subsequently, when the standby control is returned to high (+5V, for example), the power amplifier will become active again.

The protection level must be set using the 82k Ω resistor. Furthermore, the time constant must be determined using 22 μ /22 μ capacitors to prevent the amplifier from malfunctioning due to the audio signal.

STK415-120-E

STK415-100 Series BTL Application

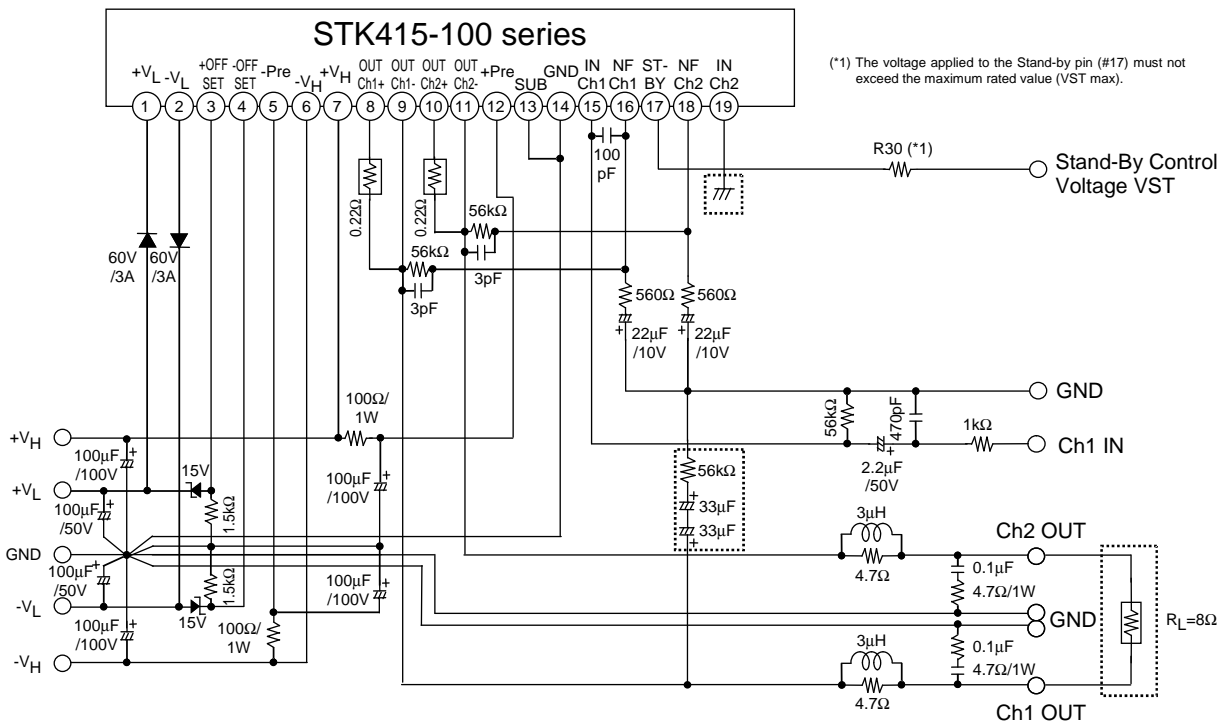

- SANYO Semiconductor Co.,Ltd. assumes no responsibility for equipment failures that result from using products at values that exceed, even momentarily, rated values (such as maximum ratings, operating condition ranges, or other parameters) listed in products specifications of any and all SANYO Semiconductor Co.,Ltd. products described or contained herein.
- SANYO Semiconductor Co.,Ltd. strives to supply high-quality high-reliability products, however, any and all semiconductor products fail or malfunction with some probability. It is possible that these probabilistic failures or malfunction could give rise to accidents or events that could endanger human lives, trouble that could give rise to smoke or fire, or accidents that could cause damage to other property. When designing equipment, adopt safety measures so that these kinds of accidents or events cannot occur. Such measures include but are not limited to protective circuits and error prevention circuits for safe design, redundant design, and structural design.
- In the event that any or all SANYO Semiconductor Co.,Ltd. products described or contained herein are controlled under any of applicable local export control laws and regulations, such products may require the export license from the authorities concerned in accordance with the above law.
- No part of this publication may be reproduced or transmitted in any form or by any means, electronic or mechanical, including photocopying and recording, or any information storage or retrieval system, or otherwise, without the prior written consent of SANYO Semiconductor Co.,Ltd.
- Any and all information described or contained herein are subject to change without notice due to product/technology improvement, etc. When designing equipment, refer to the "Delivery Specification" for the SANYO Semiconductor Co.,Ltd. product that you intend to use.
- Information (including circuit diagrams and circuit parameters) herein is for example only; it is not guaranteed for volume production.
- Upon using the technical information or products described herein, neither warranty nor license shall be granted with regard to intellectual property rights or any other rights of SANYO Semiconductor Co.,Ltd. or any third party. SANYO Semiconductor Co.,Ltd. shall not be liable for any claim or suits with regard to a third party's intellectual property rights which has resulted from the use of the technical information and products mentioned above.

This catalog provides information as of July 2009. Specifications and information herein are subject to change without notice.